

Instruction Manual
for AC Generators
English

QAS 30-40 Kd

Machine Verhuur Oosterwolde

Machine Verhuur Oosterwolde

QAS 30-40 Kd

Instruction Manual for AC Generators

Machine Verhuur Oosterwold

| | |
|--------------------------|----|
| Instruction manual | 5 |
| Circuit diagrams | 71 |

Printed matter N°
2954 3400 01

04/2008



ATLAS COPCO - PORTABLE AIR DIVISION
www.atlascopco.com

Warranty and Liability Limitation

Use only authorized parts.

Any damage or malfunction caused by the use of unauthorized parts is not covered by Warranty or Product Liability.

The manufacturer does not accept any liability for any damage arising for modifications, additions or conversions made without the manufacturer's approval in writing.

Copyright 2008, Atlas Copco Airpower n.v., Antwerp, Belgium.

Any unauthorized use or copying of the contents or any part thereof is prohibited.

This applies in particular to trademarks, model denominations, part numbers and drawings.

Congratulations on the purchase of your AC generator. It is a solid, safe and reliable machine, built according to the latest technology. Follow the instructions in this booklet and we guarantee you years of troublefree operation. Please read the following instructions carefully before starting to use your machine.

While every effort has been made to ensure that the information in this manual is correct, Atlas Copco does not assume responsibility for possible errors. Atlas Copco reserves the right to make changes without prior notice.

Contents

| | | | | | |
|---|----|---|----|--|----|
| Safety precautions for portable generators | 6 | Maintenance | 42 | Options available for QAS 30 and QAS 40 units | 53 |
| Leading particulars | 13 | Maintenance schedule | 42 | Circuit diagrams..... | 53 |
| General description | 13 | Engine maintenance..... | 44 | Overview of the electrical options..... | 53 |
| Bodywork | 15 | (*) Measuring the alternator insulation resistance..... | 44 | Description of the electrical options | 54 |
| Markings..... | 15 | Engine oil specifications | 44 | Overview of the mechanical options | 58 |
| Drain plugs and filler caps | 16 | Engine oil level check..... | 45 | Description of the mechanical options . | 58 |
| Control and indicator panel Qc1002™.. | 16 | Engine oil and oil filter change..... | 45 | Technical specifications | 60 |
| Control and indicator panel Qc2002™.. | 23 | Engine coolant specifications | 46 | Technical specifications for QAS 30 units | 60 |
| Output terminal board | 35 | Coolant check..... | 47 | Technical specifications for QAS 40 units | 65 |
| Spillage free | 36 | Storage of the generator | 48 | Conversion list of SI units into British units | 70 |
| Operating instructions | 36 | Storage | 48 | Dataplate | 70 |
| Installation..... | 36 | Preparing for operation after storage ... | 48 | | |
| Connecting the generator..... | 37 | Checks and trouble shooting | 48 | | |
| Before starting | 38 | Checking voltmeter P4 | 49 | | |
| Operating Qc1002™ | 39 | Checking ammeters P1, P2 and P3..... | 49 | | |
| Operating Qc2002™ | 40 | Alternator troubleshooting | 50 | | |
| | | Engine trouble shooting..... | 51 | | |

Safety precautions for portable generators

To be read attentively and acted accordingly before towing, lifting, operating, performing maintenance or repairing the generator.

Introduction

The policy of Atlas Copco is to provide the users of their equipment with safe, reliable and efficient products. Factors taken into account are among others:

- the intended and predictable future use of the products, and the environments in which they are expected to operate,
- applicable rules, codes and regulations,
- the expected useful product life, assuming proper service and maintenance,
- providing the manual with up-to-date information.

Before handling any product, take time to read the relevant instruction manual. Besides giving detailed operating instructions, it also gives specific information about safety, preventive maintenance, etc.

Keep the manual always at the unit location, easy accessible to the operating personnel.

See also the safety precautions of the engine and possible other equipment, which are separately sent along or are mentioned on the equipment or parts of the unit.

These safety precautions are general and some statements will therefore not always apply to a particular unit.

Only people that have the right skills should be allowed to operate, adjust, perform maintenance or repair on Atlas Copco equipment. It is the responsibility of management to appoint operators with the appropriate training and skill for each category of job.

Skill level 1: Operator

An operator is trained in all aspects of operating the unit with the push-buttons, and is trained to know the safety aspects.

Skill level 2: Mechanical technician

A mechanical technician is trained to operate the unit the same as the operator. In addition, the mechanical technician is also trained to perform maintenance and repair, as described in the instruction manual, and is allowed to change settings of the control and safety system. A mechanical technician does not work on live electrical components.

Skill level 3: Electrical technician

An electrical technician is trained and has the same qualifications as both the operator and the mechanical technician. In addition, the electrical technician may carry out electrical repairs within the various enclosures of the unit. This includes work on live electrical components.

Skill level 4: Specialist from the manufacturer

This is a skilled specialist sent by the manufacturer or its agent to perform complex repairs or modifications to the equipment.

In general it is recommended that not more than two people operate the unit, more operators could lead to unsafe operating conditions. Take necessary steps to keep unauthorized persons away from the unit and eliminate all possible sources of danger at the unit.

When handling, operating, overhauling and/or performing maintenance or repair on Atlas Copco equipment, the mechanics are expected to use safe engineering practices and to observe all relevant local safety requirements and ordinances. The following list is a reminder of special safety directives and precautions mainly applicable to Atlas Copco equipment.

Neglecting the safety precautions may endanger people as well as environment and machinery:

- endanger people due to electrical, mechanical or chemical influences,
- endanger the environment due to leakage of oil, solvents or other substances,
- endanger the machinery due to function failures.

All responsibility for any damage or injury resulting from neglecting these precautions or by non-observance of ordinary caution and due care required in handling, operating, maintenance or repair, also if not expressly mentioned in this instruction manual, is disclaimed by Atlas Copco.

The manufacturer does not accept any liability for any damage arising from the use of non-original parts and for modifications, additions or conversions made without the manufacturer's approval in writing.

If any statement in this manual does not comply with local legislation, the stricter of the two shall be applied.

Statements in these safety precautions should not be interpreted as suggestions, recommendations or inducements that it should be used in violation of any applicable laws or regulations.

General safety precautions

- 1 The owner is responsible for maintaining the unit in a safe operating condition. Unit parts and accessories must be replaced if missing or unsuitable for safe operation.
- 2 The supervisor, or the responsible person, shall at all times make sure that all instructions regarding machinery and equipment operation and maintenance are strictly followed and that the machines with all accessories and safety devices, as well as the consuming devices, are in good repair, free of abnormal wear or abuse, and are not tampered with.
- 3 Whenever there is an indication or any suspicion that an internal part of a machine is overheated, the machine shall be stopped but no inspection covers shall be opened before sufficient cooling time has elapsed; this to avoid the risk of spontaneous ignition of oil vapour when air is admitted.
- 4 Normal ratings (pressures, temperatures, speeds, etc.) shall be durably marked.
- 5 Operate the unit only for the intended purpose and within its rated limits (pressure, temperature, speeds, etc.).
- 6 The machinery and equipment shall be kept clean, i.e. as free as possible from oil, dust or other deposits.
- 7 To prevent an increase in working temperature, inspect and clean heat transfer surfaces (cooler fins, intercoolers, coolant jackets, etc.) regularly. See the maintenance schedule.
- 8 All regulating and safety devices shall be maintained with due care to ensure that they function properly. They may not be put out of action.
- 9 Pressure and temperature gauges shall be checked regularly with regard to their accuracy. They shall be replaced whenever outside acceptable tolerances.
- 10 Safety devices shall be tested as described in the maintenance schedule of the instruction manual to determine that they are in good operating condition.
- 11 Mind the markings and information labels on the unit.
- 12 In the event the safety labels are damaged or destroyed, they must be replaced to ensure operator safety.
- 13 Keep the work area neat. Lack of order will increase the risk of accidents.

- 14 When working on the unit, wear safety clothing. Depending on the kind of activities these are: safety glasses, ear protection, safety helmet (including visor), safety gloves, protective clothing, safety shoes. Do not wear the hair long and loose (protect long hair with a hairnet), or wear loose clothing or jewellery.
- 15 Take precautions against fire. Handle fuel, oil and anti-freeze with care because they are inflammable substances. Do not smoke or approach with naked flame when handling such substances. Keep a fire-extinguisher in the vicinity.

16a Portable generators (with earthing pin):

Earth the generator as well as the load properly.

16b Portable generators IT:

Note: This generator is built to supply a sheer alternating current IT network.
Earth the load properly.

Safety during transport and installation

To lift a unit, all loose or pivoting parts, e.g. doors and towbar, shall first be securely fastened.

Do not attach cables, chains or ropes directly to the lifting eye; apply a crane hook or lifting shackle meeting local safety regulations. Never allow sharp bends in lifting cables, chains or ropes.

Helicopter lifting is not allowed.

It is strictly forbidden to dwell or stay in the risk zone under a lifted load. Never lift the unit over people or residential areas. Lifting acceleration and retardation shall be kept within safe limits.

1 Before towing the unit:

- check the towbar, the brake system and the towing eye. Also check the coupling of the towing vehicle,
- check the towing and brake capability of the towing vehicle,
- check that the towbar, jockey wheel or stand leg is safely locked in the raised position,
- ascertain that the towing eye can swivel freely on the hook,
- check that the wheels are secure and that the tyres are in good condition and inflated correctly,
- connect the signalisation cable, check all lights and connect the pneumatic brake couplers,
- attach the safety break-away cable or safety chain to the towing vehicle,
- remove wheel chocks, if applied, and disengage the parking brake.

2 To tow a unit use a towing vehicle of ample capacity. Refer to the documentation of the towing vehicle.

3 If the unit is to be backed up by the towing vehicle, disengage the overrun brake mechanism (if it is not an automatic mechanism).

4 Never exceed the maximum towing speed of the unit (mind the local regulations).

5 Place the unit on level ground and apply the parking brake before disconnecting the unit from the towing vehicle. Unclip the safety break-away cable or safety chain. If the unit has no parking brake or jockey wheel, immobilize the unit by placing chocks in front of and/or behind the wheels. When the towbar can be positioned vertically, the locking device must be applied and kept in good order.

6 To lift heavy parts, a hoist of ample capacity, tested and approved according to local safety regulations, shall be used.

7 Lifting hooks, eyes, shackles, etc., shall never be bent and shall only have stress in line with their design load axis. The capacity of a lifting device diminishes when the lifting force is applied at an angle to its load axis.

8 For maximum safety and efficiency of the lifting apparatus all lifting members shall be applied as near to perpendicular as possible. If required, a lifting beam shall be applied between hoist and load.

9 Never leave a load hanging on a hoist.

10 A hoist has to be installed in such a way that the object will be lifted perpendicular. If that is not possible, the necessary precautions must be taken to prevent load-swinging, e.g. by using two hoists, each at approximately the same angle not exceeding 30° from the vertical.

11 Locate the unit away from walls. Take all precautions to ensure that hot air exhausted from the engine and driven machine cooling systems cannot be recirculated. If such hot air is taken in by the engine or driven machine cooling fan, this may cause overheating of the unit; if taken in for combustion, the engine power will be reduced.

12 Generators shall be stalled on an even, solid floor, in a clean location with sufficient ventilation. If the floor is not level or can vary in inclination, consult Atlas Copco.

13 The electrical connections shall correspond to local codes. The machines shall be earthed and protected against short circuits by fuses or circuit breakers.

14 Never connect the generator outlets to an installation which is also connected to a public mains.

15 Before connecting a load, switch off the corresponding circuit breaker, and check whether frequency, voltage, current and power factor comply with the ratings of the generator.

Safety during use and operation

- 1 When the unit has to operate in a fire-hazardous environment, each engine exhaust has to be provided with a spark arrestor to trap incendiary sparks.
- 2 The exhaust contains carbon monoxide which is a lethal gas. When the unit is used in a confined space, conduct the engine exhaust to the outside atmosphere by a pipe of sufficient diameter; do this in such a way that no extra back pressure is created for the engine. If necessary, install an extractor. Observe any existing local regulations.

Make sure that the unit has sufficient air intake for operation. If necessary, install extra air intake ducts.
- 3 When operating in a dust-laden atmosphere, place the unit so that dust is not carried towards it by the wind. Operation in clean surroundings considerably extends the intervals for cleaning the air intake filters and the cores of the coolers.
- 4 Never remove a filler cap of the coolant system of a hot engine. Wait until the engine has sufficiently cooled down.
- 5 Never refill fuel while the unit is running, unless otherwise stated in the Atlas Copco Instruction Book (AIB). Keep fuel away from hot parts such as air outlet pipes or the engine exhaust. Do not smoke when fuelling. When fuelling from an automatic pump, an earthing cable should be connected to the unit to discharge static electricity. Never spill nor leave oil, fuel, coolant or cleansing agent in or around the unit.

- 6 All doors shall be shut during operation so as not to disturb the cooling air flow inside the bodywork and/or render the silencing less effective. A door should be kept open for a short period only e.g. for inspection or adjustment.
- 7 Periodically carry out maintenance works according to the maintenance schedule.
- 8 Stationary housing guards are provided on all rotating or reciprocating parts not otherwise protected and which may be hazardous to personnel. Machinery shall never be put into operation, when such guards have been removed, before the guards are securely reinstalled.
- 9 Noise, even at reasonable levels, can cause irritation and disturbance which, over a long period of time, may cause severe injuries to the nervous system of human beings.
When the sound pressure level, at any point where personnel normally has to attend, is:
 - below 70 dB(A): no action needs to be taken,
 - above 70 dB(A): noise-protective devices should be provided for people continuously being present in the room,
 - below 85 dB(A): no action needs to be taken for occasional visitors staying a limited time only,
 - above 85 dB(A): room to be classified as a noise-hazardous area and an obvious warning shall be placed permanently at each entrance to alert people entering the room, for even relatively short times, about the need to wear ear protectors,

- above 95 dB(A): the warning(s) at the entrance(s) shall be completed with the recommendation that also occasional visitors shall wear ear protectors,
 - above 105 dB(A): special ear protectors that are adequate for this noise level and the spectral composition of the noise shall be provided and a special warning to that effect shall be placed at each entrance.
- 10 Insulation or safety guards of parts the temperature of which can be in excess of 80°C (175°F) and which may be accidentally touched by personnel shall not be removed before the parts have cooled to room temperature.
 - 11 Never operate the unit in surroundings where there is a possibility of taking in flammable or toxic fumes.
 - 12 If the working process produces fumes, dust or vibration hazards, etc., take the necessary steps to eliminate the risk of personnel injury.
 - 13 When using compressed air or inert gas to clean down equipment, do so with caution and use the appropriate protection, at least safety glasses, for the operator as well as for any bystander. Do not apply compressed air or inert gas to your skin or direct an air or gas stream at people. Never use it to clean dirt from your clothes.
 - 14 When washing parts in or with a cleaning solvent, provide the required ventilation and use appropriate protection such as a breathing filter, safety glasses, rubber apron and gloves, etc.

- 15 Safety shoes should be compulsory in any workshop and if there is a risk, however small, of falling objects, wearing of a safety helmet should be included.
- 16 If there is a risk of inhaling hazardous gases, fumes or dust, the respiratory organs must be protected and depending on the nature of the hazard, so must the eyes and skin.
- 17 Remember that where there is visible dust, the finer, invisible particles will almost certainly be present too; but the fact that no dust can be seen is not a reliable indication that dangerous, invisible dust is not present in the air.
- 18 Never operate the generator in excess of its limits as indicated in the technical specifications and avoid long no-load sequences.
- 19 Never operate the generator in a humid atmosphere. Excessive moisture causes worsening of the generator insulation.
- 20 Do not open electrical cabinets, cubicles or other equipment while voltage is supplied. If such cannot be avoided, e.g. for measurements, tests or adjustments, have the action carried out by a qualified electrician only, with appropriate tools, and ascertain that the required bodily protection against electrical hazards is applied.
- 21 Never touch the power terminals during operation of the machine.
- 22 Whenever an abnormal condition arises, e.g. excessive vibration, noise, odour, etc., switch the circuit breakers to OFF and stop the engine. Correct the faulty condition before restarting.
- 23 Check the electric cables regularly. Damaged cables and insufficient tightening of connections may cause electric shocks. Whenever damaged wires or dangerous conditions are observed, switch the circuit breakers to OFF and stop the engine. Replace the damaged wires or correct the dangerous condition before restarting. Make sure that all electric connections are securely tightened.
- 24 Avoid overloading the generator. The generator is provided with circuit breakers for overload protection. When a breaker has tripped, reduce the concerned load before restarting.
- 25 If the generator is used as stand-by for the mains supply, it must not be operated without control system which automatically disconnects the generator from the mains when the mains supply is restored.
- 26 Never remove the cover of the output terminals during operation. Before connecting or disconnecting wires, switch off the load and the circuit breakers, stop the machine and make sure that the machine cannot be started inadvertently or there is any residual voltage on the power circuit.
- 27 Running the generator at low load for long periods will reduce the lifetime of the engine.

Safety during maintenance and repair

Maintenance, overhaul and repair work shall only be carried out by adequately trained personnel; if required, under supervision of someone qualified for the job.

- 1 Use only the correct tools for maintenance and repair work, and only tools which are in good condition.
- 2 Parts shall only be replaced by genuine Atlas Copco replacement parts.
- 3 All maintenance work, other than routine attention, shall only be undertaken when the unit is stopped. Steps shall be taken to prevent inadvertent starting. In addition, a warning sign bearing a legend such as “work in progress; do not start” shall be attached to the starting equipment.
On engine-driven units the battery shall be disconnected and removed or the terminals covered by insulating caps.
On electrically driven units the main switch shall be locked in open position and the fuses shall be taken out. A warning sign bearing a legend such as “work in progress; do not supply voltage” shall be attached to the fuse box or main switch.
- 4 Prior to stripping an engine or other machine or undertaking major overhaul on it, prevent all movable parts from rolling over or moving.

- 5 Make sure that no tools, loose parts or rags are left in or on the machine. Never leave rags or loose clothing near the engine air intake.
- 6 Never use flammable solvents for cleaning (fire-risk).
- 7 Take safety precautions against toxic vapours of cleaning liquids.
- 8 Never use machine parts as a climbing aid.
- 9 Observe scrupulous cleanliness during maintenance and repair. Keep away dirt, cover the parts and exposed openings with a clean cloth, paper or tape.
- 10 Never weld on or perform any operation involving heat near the fuel or oil systems. Fuel and oil tanks must be completely purged, e.g. by steam-cleaning, before carrying out such operations. Never weld on, or in any way modify, pressure vessels. Disconnect the alternator cables during arc welding on the unit.
- 11 Support the towbar and the axle(s) securely if working underneath the unit or when removing a wheel. Do not rely on jacks.
- 12 Do not remove any of, or tamper with, the sound-damping material. Keep the material free of dirt and liquids such as fuel, oil and cleansing agents. If any sound-damping material is damaged, replace it to prevent the sound pressure level from increasing.
- 13 Use only lubricating oils and greases recommended or approved by Atlas Copco or the machine manufacturer. Ascertain that the selected lubricants comply with all applicable safety regulations, especially with regard to explosion or fire-risk and the possibility of decomposition or generation of hazardous gases. Never mix synthetic with mineral oil.
- 14 Protect the engine, alternator, air intake filter, electrical and regulating components, etc., to prevent moisture ingress, e.g. when steam-cleaning.
- 15 When performing any operation involving heat, flames or sparks on a machine, the surrounding components shall first be screened with non-flammable material.
- 16 Never use a light source with open flame for inspecting the interior of a machine.
- 17 When repair has been completed, the machine shall be barred over at least one revolution for reciprocating machines, several revolutions for rotary ones to ensure that there is no mechanical interference within the machine or driver. Check the direction of rotation of electric motors when starting up the machine initially and after any alteration to the electrical connection(s) or switch gear, to check that the oil pump and the fan function properly.
- 18 Maintenance and repair work should be recorded in an operator's logbook for all machinery. Frequency and nature of repairs can reveal unsafe conditions.
- 19 When hot parts have to be handled, e.g. shrink fitting, special heat-resistant gloves shall be used and, if required, other body protection shall be applied.
- 20 When using cartridge type breathing filter equipment, ascertain that the correct type of cartridge is used and that its useful service life is not surpassed.
- 21 Make sure that oil, solvents and other substances likely to pollute the environment are properly disposed of.
- 22 Before clearing the generator for use after maintenance or overhaul, submit it to a testrun, check that the AC power performance is correct and that the control and shutdown devices function correctly.

Tool applications safety

Apply the proper tool for each job. With the knowledge of correct tool use and knowing the limitations of tools, along with some common sense, many accidents can be prevented.

Special service tools are available for specific jobs and should be used when recommended. The use of these tools will save time and prevent damage to parts.

Battery safety precautions

Batteries

When servicing batteries, always wear protecting clothing and glasses.

- 1 The electrolyte in batteries is a sulphuric acid solution which is fatal if it hits your eyes, and which can cause burns if it contacts your skin. Therefore, be careful when handling batteries, e.g. when checking the charge condition.
- 2 Install a sign prohibiting fire, open flame and smoking at the post where batteries are being charged.
- 3 When batteries are being charged, an explosive gas mixture forms in the cells and might escape through the vent holes in the plugs.
Thus an explosive atmosphere may form around the battery if ventilation is poor, and can remain in and around the battery for several hours after it has been charged. Therefore:
 - never smoke near batteries being, or having recently been, charged,
 - never break live circuits at battery terminals, because a spark usually occurs.

- 4 When connecting an auxiliary battery (AB) in parallel to the unit battery (CB) with booster cables: connect the + pole of AB to the + pole of CB, then connect the - pole of CB to the mass of the unit. Disconnect in the reverse order.

Leading particulars

General description

The QAS 30 and QAS 40 are AC generators, built for continuous running at sites where no electricity is available or as stand-by in cases of interruption of the mains. The generator operates at 50/60 Hz, 230/240 V in line-to-neutral mode and 400/480 V in line-to-line mode. The QAS 30 and QAS 40 generators are driven by a fluid-cooled diesel engine, manufactured by KUBOTA. An overview of the main parts is given in the diagram below.

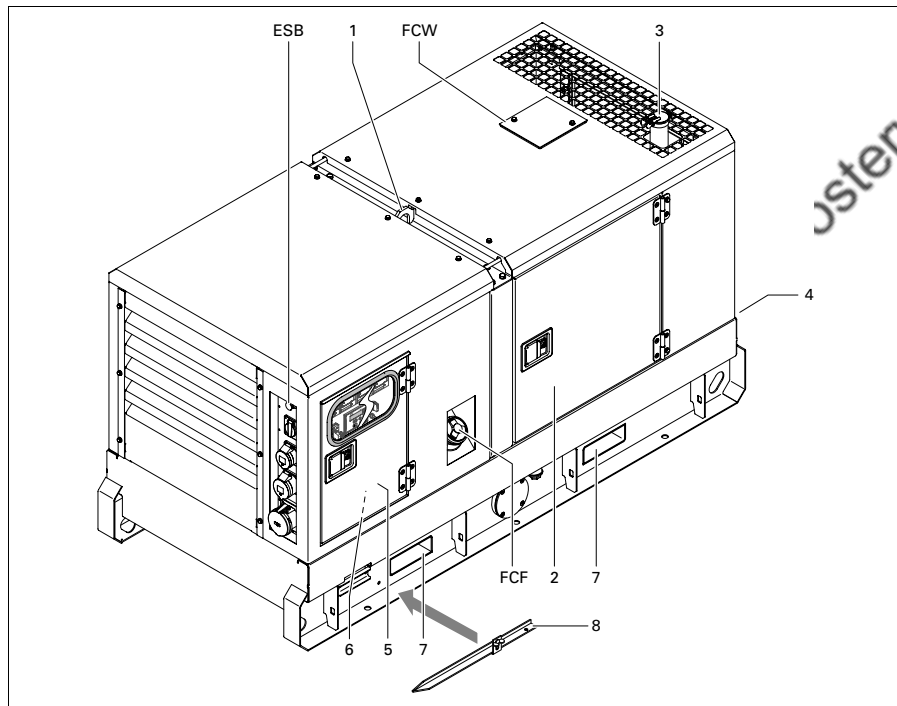

- | | |
|-----|--|
| 1 | Lifting beam |
| 2 | Side doors |
| 3 | Engine exhaust |
| 4 | Data Plate |
| 5 | Door, access to control and indicator panel |
| 6 | Output terminal board |
| 7 | Hole for forklift |
| 8 | Earthing rod (not available in combination with an IT-relay) |
| ESB | Emergency stop button |
| FCF | Filler cap fuel |
| FCW | Filler cap coolant |

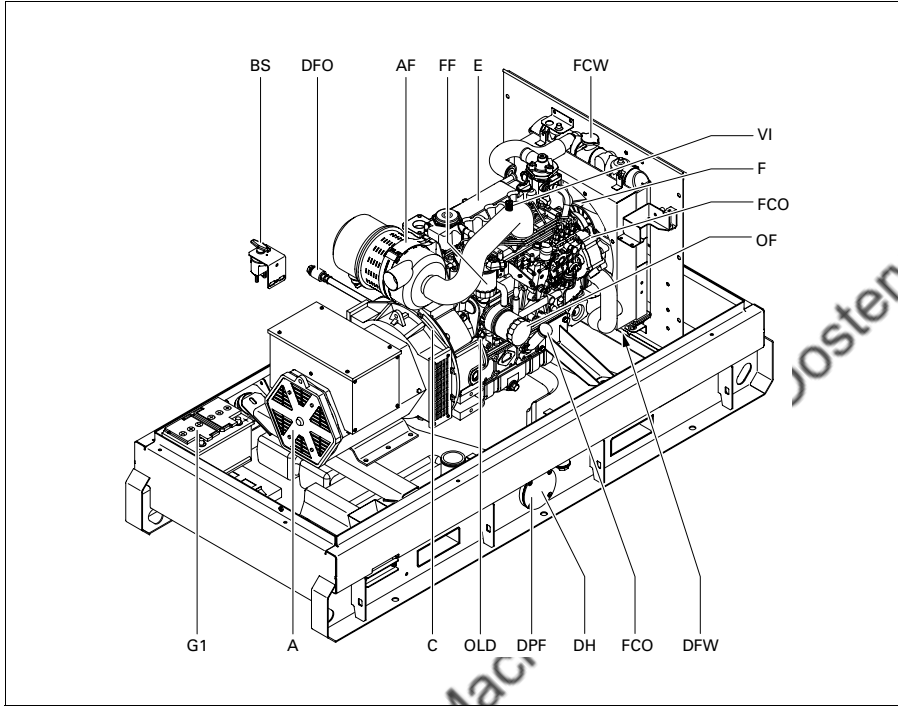

- A Alternator
- AF Air filter
- BS Battery switch
- C Coupling
- DFO Drain flexible engine oil
- DFW Drain flexible coolant
- DH Drain and access hole (in the frame)
- DPF Drain plug fuel
- E Engine
- F Fan
- FCF Filler cap fuel
- FCO Filler cap engine oil
- FCW Filler cap coolant
- FF Fuel filter
- G1 Battery
- OF Oil filter
- OLD Engine oil level dipstick
- VI Vacuum indicator

Bodywork

The alternator, the engine, the cooling system, etc. are enclosed in a sound-insulated bodywork that can be opened by means of side doors (and service plates).

The recess in the roof has a lifting rod in the middle.



Never use the guiding rods to lift the generator.

To be able to lift the generator by means of a forklift, rectangular holes are provided in the frame.

The earthing rod, connected to the generator's earth terminal is located at the side of the frame.

Markings

A brief description of all markings provided on the generator is given hereafter.



Indicates that the engine exhaust is a hot and harmful gas, which is toxic in case of inhalation. Always make sure that the unit is operated outside or in a well-ventilated room.



Indicates that these parts can become very hot during operation (e.g. engine, cooler, etc.). Always make sure that these parts are cooled down before touching them.



Indicates that the guiding rods may not be used to lift the generator. Always use the lifting rod in the roof of the generator to lift it.



Indicates a lifting point of the generator.

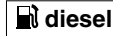

Indicates that the generator may be refuelled with diesel fuel only.



Indicates the drain for the engine oil.



Indicates the drain for the coolant.



Indicates the drain plug for the engine fuel.



Use PAROIL 15W40 only.



Indicates the different earthing connections on the generator.



Indicates that the alternator should not be cleaned with high pressurised water.

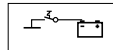

Indicates the battery switch.

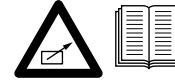

Indicates that the unit may start automatically and that the instruction book has to be consulted prior to use.



Read the instruction manual before using the lifting eye.

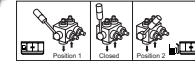

Indicates the 3-way valve.

| Atlas Copco | | | |
|-----------------------|-------------------|--------------|--------------|
| OAS 30 Kd, OAS 40 Kd | | | |
| SERVICE PACK | | | |
| | Every 500h (max) | 2912.6581.05 | |
| | Every 1000h | 2912.6592.05 | |
| Engine oil | | | |
| | 5 l (11.02 gal) | 1615.5963.00 | 1604.6060.01 |
| | 20 l (44.06 gal) | 1615.5954.00 | 1604.6059.01 |
| | 210 l (462.6 gal) | 1615.5955.00 | |
| Engine coolant | | | |
| | 2 l (4.4068 gal) | 1604.5260.00 | |
| | 20 l (44.06 gal) | 1604.5307.01 | |
| | 210 l (462.6 gal) | 1604.5260.00 | 1604.5260.00 |

Indicates the partnumbers of the different service packs and of the engine oil. These parts can be ordered to the factory.

Drain plugs and filler caps

The drain holes for the engine oil, the coolant and the plug for the fuel, are located and labelled on the frame; the fuel drain plug at the front, the others at the service side.

The drain flexible for engine oil can be brought to the outside of the generator through the drain hole.



The drain hole can also be used to guide external fuel tank connections. When connecting an external fuel tank, use the 3-way valves. Refer to External fuel tank connection (with/without quick couplings).

The filler cap for the engine coolant is accessible via an opening in the roof. The fuel filler cap is located in the side panel.

Control and indicator panel Qc1002™

General description Qc1002™ control panel

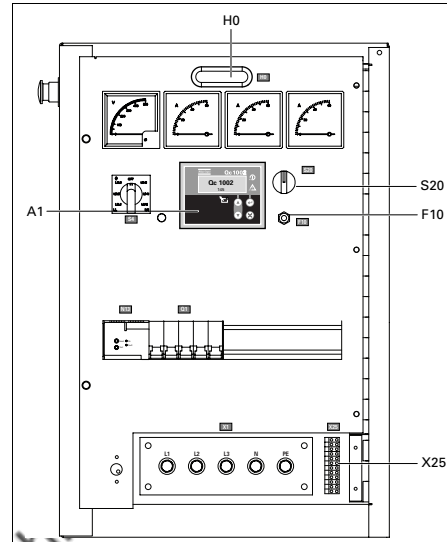

A1 Qc1002™ display

F10 Fuse

The fuse activates when the current from the battery to the engine control circuit exceeds its setting. The fuse can be reset by pushing the button.

H0 Panel light

S20 ON/OFF/REMOTE switch

To start up the unit (locally or remote).

X25 Terminal strip

Qc1002™ Module

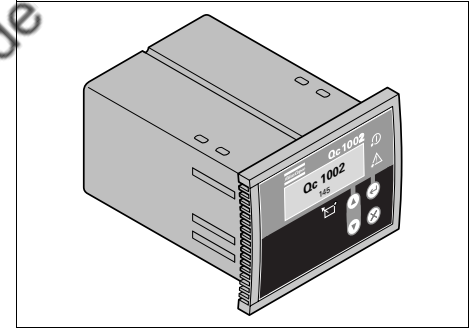

The Qc1002™ module is located inside the control panel. This control module will carry out all necessary tasks to control and protect a generator, regardless of the use of the generator.

This means that the Qc1002™ module can be used for several applications.

Pushbutton and LED functions

Following pushbuttons are used on the Qc1002™



ENTER: Is used to select and confirm changed settings in the Parameter list.



UP: Is used to scroll through the display information and to adjust parameter value upwards.



DOWN: Is used to scroll through the display information and to adjust parameter value downwards.



BACK: Is used to leave the Alarm pop-up window, to leave the Parameter list and to leave menu's without change.

Following LEDs are used on the Qc1002™

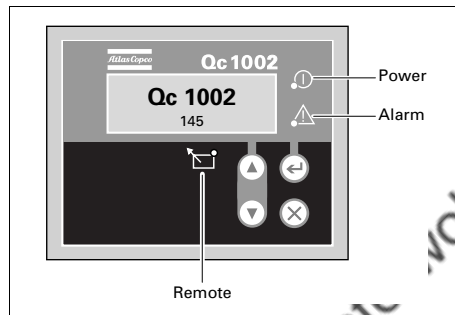

Power

Green LED indicates that the unit is powered up.

Remote

Green LED indicates that the Remote Mode is selected.

Alarm

Flashing red LED indicates that an alarm is present. A continuous red LED indicates that the alarm has been acknowledged by the user. The exact alarm is shown on the display.

Qc1002™ Menu Overview

At Qc1002™, the LCD will show following information:

- in **Normal** condition (scroll through the information using **UP** and **DOWN**):
 - Status (eg: preheat, crank, run, cooldown, extended stop time, ...)
 - Controller type & version
 - Parameter list
 - Alarm list
 - LOG list
 - Service Timer 1 & Service Timer 2
 - Battery Voltage
 - Fuel level
 - Voltage - frequency - running hours

- in **Alarm** condition (scroll through the information using **UP** and **DOWN**):
 - a list of all active Alarms

It's possible to scroll through the views, using the **UP** and **DOWN** buttons. The scrolling is continuous.

If a Special status comes up, the Status Display is shown.

If an Alarm comes up, the Alarm Display is shown.

Controller type and version display



This view shows the controller type and the ASW version number.

Parameter display

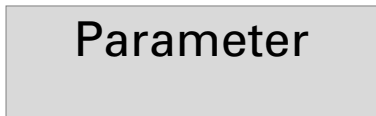

This view shows a number of Parameter settings and gives access to them.

An overview is given in "Parameter list" on page 19.

Alarm list display

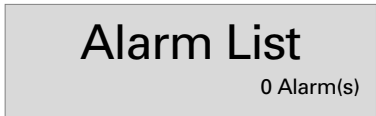

This view shows the number of active alarms and gives access to them.

An overview is given in "Alarm Display (pop-up window)" on page 21.

LOG list display

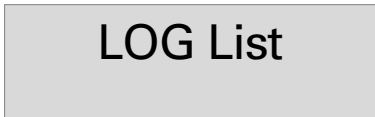

This view shows the alarm memory and gives access to it.

An overview is given in "LOG list" on page 22.

Service timer 1 & Service timer 2 display

| | |
|-----------|-----|
| Service 1 | 59h |
| Service 2 | 59h |

This view shows both Service timers. The service timer indication is shown when service time has run out. It can be removed by resetting the timers or acknowledging the Service timer indication.

The service timer indications count and give an alarm when value is reached.

Resetting the Service Timers can be done through the Parameter display.

Battery Voltage display

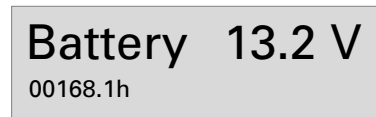

This view shows the Battery voltage and the running hours.

Fuel level display

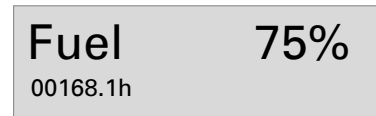

This view shows the Fuel level and the running hours.

Voltage - frequency - running hours display

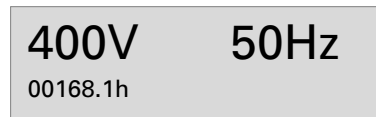

This view shows the voltage, frequency and running hours.

Qc1002™ Menu Description

Status Display (pop-up window)

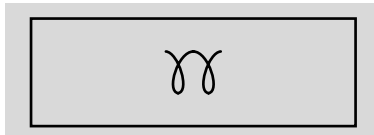

In case special statuses are entered, a pop-up window will automatically be entered for as long as the status is active.

The background screen is not updated when the status pop-up window is active.

These special statuses are:

PREHEAT



START OFF/
EXTENDED
STOP TIMER



COOLDOWN



If a special status has elapsed, the active view will be entered again automatically.

If an Alarm comes up, the Alarm Display is shown.

Parameter list

The Parameter Menu's are pre-programmed!

A password will be asked for when an attempt to change a setting is about to be done (user password = 2003).

Menu's shown on the Parameter list LCD:

- Running hours adjust

This menu is used to adjust the amount of running hours. The running hours can only be raised, not lowered.

- Unit Type



Unit type 1 for QAS 30-40 !

- Service Timer 2 reset
- Service Timer 1 reset

These menus are used to reset the service timers. When a service timer alarm occurs and is acknowledged, the service timer will be reset automatically.

- Unit Menu

This menu is used to select whether temperature and pressure should appear in °C/bar or °F/psi.

- Language selection

Icons is the default factory set language, but 6 other languages can be selected: English, French, German, Italian, Spanish and Cyrillic (Russian). All information in the Parameter List display is always in English.

- Generator Underfrequency: failclass, enable, delay, setpoint
- Generator Overfrequency: failclass, enable, delay, setpoint
- Generator Undervoltage: failclass, enable, delay, setpoint
- Generator Overvoltage: failclass, enable, delay, setpoint

It's possible to scroll between configuration menu's by using the pushbuttons UP and DOWN.

Pushing the ENTER button activates the configuration menu which is shown at the display.

This is the described menu flow for changing the unit type:

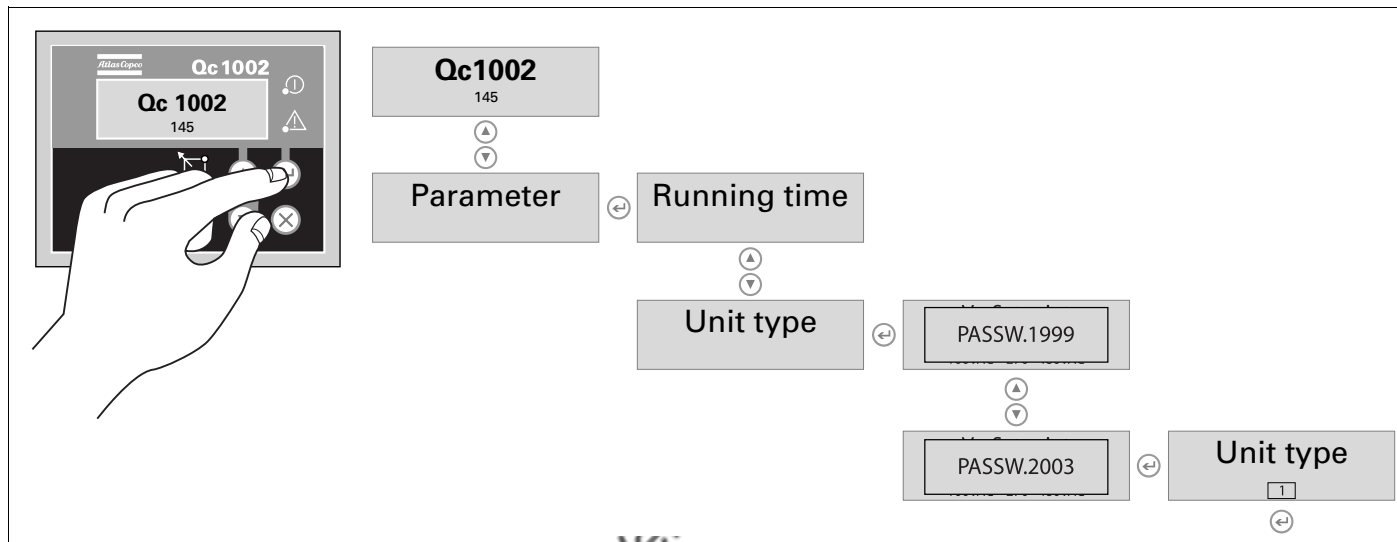

Machine Ve

Alarm Display (pop-up window)

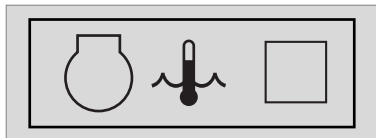

In case an Alarm occurs, a pop-up window will automatically be displayed for as long as the alarm is active, no matter which view is active. The flashing red alarm LED will light up. The alarm icons will be shown together with an acknowledgement check-box. Push the ENTER button to acknowledge the alarm. When the alarm has been acknowledged, a V-marking will appear in the check-box and the red alarm LED will light up continuously.



An alarm should always be acknowledged before solving the problem that causes the alarm.

The Alarm Display can always be left by pushing the BACK button.

If more than one alarm comes up, it's possible to scroll through the alarm messages with the UP and DOWN pushbuttons. The newest alarm will be placed at the bottom of the list (meaning that the older alarm stays at the display when a newer alarm comes up).

If one or more than one alarm is present, an arrow at the right of the display will be shown.

Following general groups of Alarms exist:

- Warning: Alarm LED lights up + Alarm pop-up appears on the display + Alarm relay is empowered (if configured)
- Trip of GB: 'Warning' actions + Generator Contactor opens
- Trip and Stop: 'Trip of GB' actions + unit stops after Cooldown
- Shutdown: 'Trip of GB' actions + unit stops immediately

List of possible alarms:

LOW OIL PRESSURE



HIGH COOLANT TEMPERATURE



CHARGING ALTERNATOR



LOW FUEL LEVEL

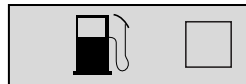

LOW COOLANT LEVEL



GENERATOR OVERVOLTAGE

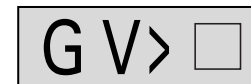

GENERATOR UNDER-VOLTAGE



GENERATOR OVER-FREQUENCY



GENERATOR UNDER-FREQUENCY



SERVICE TIMER 1

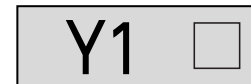

SERVICE TIMER
2

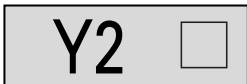

ENGINE ALARM



EMERGENCY
STOP



START FAILURE



STOP FAILURE



LOG list

The unit will keep an event log of the latest 30 events.

Events are:

- shutdowns
- service timer 1/2 reset
- unit type changes

Together with each event, the running hours at the time of the event will be stored.

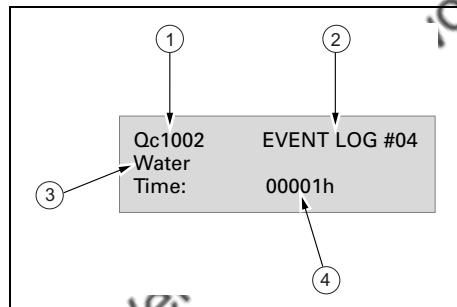

- 1 | Controller type
- 2 | Event number
- 3 | Event
- 4 | Running hours

Remote start operation

Installation wirings:

- X25.1 & X25.2 to be wired for the remote start switch.
- X25.3 & X25.4 to be wired for the remote contactor (open/close).

Fail classes

All the activated alarms of the Qc1002™ have their own pre-defined fail class.

All alarms are enabled according to one of these three statuses:

- disabled alarm, no supervision of alarm (OFF)
- enabled alarm, supervision of alarm all the time (ON)
- running alarm, only supervision when the machine is running (RUN)

Control and indicator panel Qc2002™

General description Qc2002™ control panel

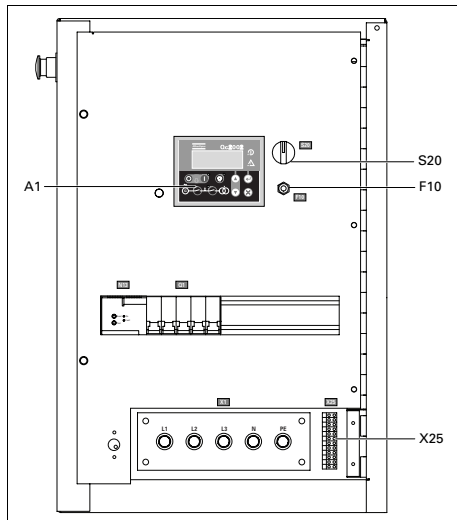

A1 Qc2002™ display

F10 Fuse

The fuse activates when the current from the battery to the engine control circuit exceeds its setting. The fuse can be reset by pushing the button.

S20 ON/OFF switch

Position O: No voltage is applied to the Qc2002™ module, the generator will not start.

Position I: Voltage is applied to the Qc2002™ module, it is possible to start up the generator.

X25 Terminal strip

Qc2002™ Module

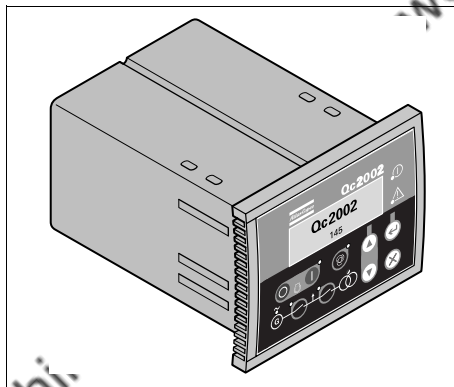

The Qc2002™ module is located inside the control panel. This control module will carry out all necessary tasks to control and protect a generator, regardless of the use of the generator.

This means that the Qc2002™ module can be used for several applications.

Pushbutton and LED functions

Following pushbuttons are used on the Qc2002™



ENTER: Is used to select and confirm changed settings in the Parameter list.



UP: Is used to scroll through the display information and to adjust parameter value upwards.



DOWN: Is used to scroll through the display information and to adjust parameter value downwards.



BACK: Is used to leave the Alarm pop-up window, to leave the Parameter list and to leave menu's without change.



AUTOMATIC: Is used to put the unit in manual or automatic operation.



START: Is used to start the unit in manual operation.



STOP: Is used to stop the unit in manual or automatic operation (without cooldown). When the unit is stopped with the STOP button in automatic operation, it will automatically go to manual operation.



MAINS CONTACTOR: Is used to open or close the Mains contactor, if the Qc2002™ is in manual operation.



GENERATOR CONTACTOR: Is used to open or close the Generator contactor, if the Qc2002™ is in manual operation

Following LEDs are used on the Qc2002™

Alarm

Flashing red LED indicates that an alarm is present. A continuous red LED indicates that the alarm has been acknowledged by the user. The exact alarm is shown on the display.

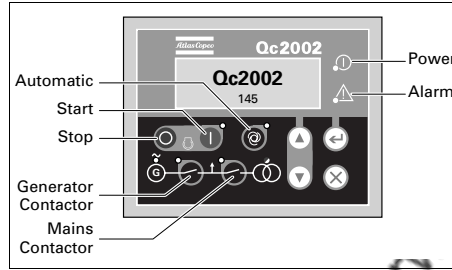

Power

Green LED indicates that the unit is powered up.

Automatic

Green LED indicates that the Qc2002™ is in automatic operation.

Start/Stop

Green LED indicates that the Qc2002™ receives running feedback (via the W/L input, via the RPM value at the Canbus, or via the AC frequency).

Generator contactor

Green LED indicates that the voltage and the frequency of the alternator are within certain limits for a certain time. It will be possible to close the Generator Contactor (both in Island and in AMF mode), if the Mains contactor is open.

Mains contactor

Green LED indicates that it is possible to close the Mains Contactor (only in AMF mode), if the Generator contactor is open.

Qc2002™ Menu Overview

At Qc2002™, the LCD will show following information:

- in **Normal** condition (scroll through the information using **UP** and **DOWN**):
 - Status (eg: preheat, crank, cooldown, extended stop time, ...) (pop-up: this display is only shown when a Special status comes up)
 - Line voltages of the generator
 - Controller type & version
 - Parameter list
 - Alarm list
 - LOG list
 - Service Timer 1 & Service Timer 2
 - Battery Voltage
 - Fuel level
 - kWh counter
 - Power factor, the frequency of the generator and the frequency of the mains
 - Line voltage, frequency and active power of the generator
 - Active, reactive and apparent power of the generator
 - Generator currents
 - Phase voltages of the mains
 - Line voltages of the mains
 - Phase voltages of the generator

– in **Alarm** condition (scroll through the information using **UP** and **DOWN**):

- a list of all active Alarms

It's possible to scroll through the views, using the **UP** and **DOWN** buttons. The scrolling is continuous.

If a Special status comes up, the Status Display is shown.

If an Alarm comes up, the Alarm Display is shown.

Line voltages generator display

| | |
|---------|------|
| G L1-L2 | 400V |
| G L2-L3 | 400V |
| G L3-L1 | 400V |

This view shows the line voltages of the generator.

Controller type and version display

Qc2002
1.00.1

This view shows the controller type and the ASW version number.

Parameter display

Parameter

This view shows a number of Parameter settings and gives access to them.

An overview is given in “Parameter list” on page 28.

Alarm list display

Alarm List

0 Alarm(s)

This view shows the number of active alarms and gives access to them.

An overview is given in “Alarm Display (pop-up window)” on page 32.

LOG list display

LOG List

This view shows the alarm memory and gives access to it.

An overview is given in “LOG list” on page 34.

Service timer 1 & Service timer 2 display

| | |
|-----------|-----|
| Service 1 | 59h |
| Service 2 | 59h |

This view shows both Service timers. The service timer indication is shown when service time has run out. It can be removed by resetting the timers or acknowledging the Service timer indication.

The service timer indications count downwards and give an alarm when the set value 0 (zero) is reached.

Resetting the Service Timers can be done through the Parameter display.

Battery voltage display

Battery 13.2 V
00168.1h

This view shows the Battery voltage and the running hours.

Fuel level display

Fuel 75%
00168.1h

This view shows the Fuel level and the running hours.

kWh counter display

E 4860kWh

This view shows the kWh counter.

Power factor - frequency generator - frequency mains display

| | |
|--------|------|
| PF | 0.00 |
| G f L1 | 50Hz |
| M f L1 | 50Hz |

This view shows the PF, the frequency of the generator and the frequency of the mains (M f L1: only in AMF mode).

One line voltage - frequency - active power display

| | |
|---------|------|
| G L1-L2 | 400V |
| G f L1 | 50Hz |
| P | 80kW |

This view shows one line voltage, frequency and active power of the generator.

Active - reactive - apparent power display

| | |
|---|-------|
| P | 80kW |
| Q | 0kVAr |
| S | 80kVA |

This view shows the active, reactive and apparent power of the generator.

Generator current display

| | |
|------|------|
| G I1 | 100A |
| G I2 | 100A |
| G I3 | 100A |

This view shows the generator current.

Phase voltages mains display

| | |
|--------|------|
| M L1-N | 230V |
| M L2-N | 230V |
| M L3-N | 230V |

This view shows the phase voltages of the mains (is only shown in AMF mode).

Line voltages mains display

| | |
|---------|------|
| M L1-L2 | 400V |
| M L2-L3 | 400V |
| M L3-L1 | 400V |

This view shows the line voltages of the mains (is only shown in AMF mode).

Phase voltages generator display

| | |
|--------|------|
| G L1-N | 230V |
| G L2-N | 230V |
| G L3-N | 230V |

This view shows the phase voltages of the generator.

Qc2002™ Menu Description

Status Display (pop-up window)

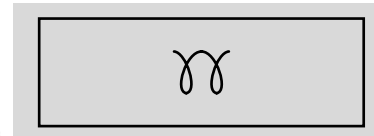

In case special statuses are entered, a pop-up window will automatically be entered for as long as the status is active.

The background screen is not updated when the status pop-up window is active.

These special statuses are:

PREHEAT



START OFF/
EXTENDED
STOP TIMER



COOLDOWN



If a special status has elapsed, the active view will be entered again automatically.
If an Alarm comes up, the Alarm Display is shown.

Parameter list

The Parameter Menu's are pre-programmed !

A password will be asked for when an attempt to change a setting is about to be done (user password = 2003).

By entering the parameter list, pushbutton AUTOMATIC is disposed of its normal operations and will not perform any functionality.

It's possible to scroll between configuration menu's by using the pushbuttons UP and DOWN.

Pushing the ENTER button activates the configuration menu which is shown at the display.

Menu's shown on the Parameter list LCD:

Genset mode

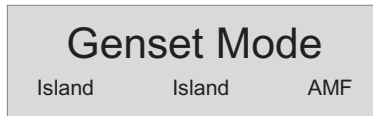

This menu is used to change the mode of the machine.
In the Qc2002™ module 2 application modes can be selected:

Island operation

- This operation type is selected for local/remote start applications, without the Mains (= stand-alone).
 - Combined with Manual Operation mode = Local Start operation.
 - The sequences start/stop/close Generator Contactor / open Generator Contactor can be activated manually.
 - Combined with Automatic Operation mode = Remote Start operation.
- The remote start signal can be given with an external switch. After the generator has been started, the Generator Contactor will close automatically.
- Installation wirings for Remote Start operation: wire the RS switch between X25.9 & X25.10.

Automatic Mains Failure (AMF) operation

- This application is only possible in combination with the Auto mode. If the Manual Operation mode is selected the AMF operation will NOT function !
- When the Mains exceeds the defined voltage / frequency limits for a defined delay time, the generator will take over the load automatically.
 - When the mains is restored within the defined limits for a defined time, the generator will unload before disconnecting and switching back to the Mains.
- The generator will then go into cooldown and stop.
- Installation wirings: we refer to circuit diagram 9822 0992 79/01 for the correct connections.

Horn delay

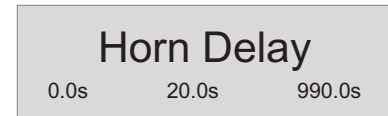

This menu is used to set the delay, how long the general alarm relay stays energized (if present). If set to 0.0s, the general alarm relay will stay energized continuously.

Running hours adjust

| | | |
|--------------|-----|-------|
| Running Time | | |
| Cur. | 168 | 20000 |

This menu is used to adjust the amount of running hours. The running hours can only be raised, not lowered.

Service timer 2 reset

| | | |
|------------|----|-----|
| St 2 Reset | | |
| No | No | Yes |

Service timer 1 reset

| | | |
|------------|----|-----|
| St 1 Reset | | |
| No | No | Yes |

These menus are used to reset the service timers. When a service timer alarm occurs and is acknowledged, the service timer will be reset automatically.

Unit menu

| | | |
|-------|-------|-------|
| Unit | | |
| C/bar | C/bar | F/psi |

This menu is used to select the units into which pressures and temperatures will be shown.

Language selection

| | | |
|----------|--|--|
| Language | | |
| English | | |

Icons is the default factory set language, but 6 other languages can be selected: English, French, German, Italian, Spanish and Cyrillic (Russian). All information in the Parameter List display is always in English.

MF high frequency

| | | |
|--------------|-----|------|
| MF high freq | | |
| 100% | 110 | 120% |

This menu is used to set the maximum limit for the mains frequency, in % of the nominal frequency (in AMF-Auto).

MF low frequency

| | | |
|-------------|----|------|
| MF low freq | | |
| 80% | 90 | 100% |

This menu is used to set the minimum limit for the mains frequency, in % of the nominal frequency (in AMF-Auto).

M frequency delay



This menu is used to set the delay, which defines how long the mains frequency has to be back within the limits before there will be switched from generator to mains again (in AMF-Auto). During this delay, the Mains LED flashes in green.

MF frequency delay



This menu is used to set the delay, which defines how long the mains frequency may be above the max limit or below the min limit before there will be switched from mains to generator (in AMF-Auto). During this delay, the Mains LED flashes in red.

MF high voltage

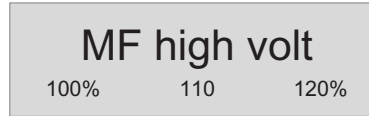

This menu is used to set the maximum limit for the mains voltage, in % of the nominal voltage (in AMF-Auto).

MF low voltage

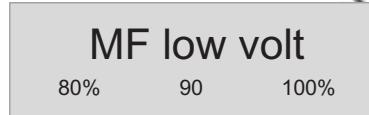

This menu is used to set the minimum limit for the mains voltage, in % of the nominal voltage (in AMF-Auto).

M voltage delay



This menu is used to set the delay, which defines how long the mains voltage has to be back within the limits before there will be switched from generator to mains again (in AMF-Auto). During this delay, the Mains LED flashes in green.

MF voltage delay



This menu is used to set the delay, which defines how long the mains voltage may be above the max limit or below the min limit before there will be switched from mains to generator (in AMF-Auto). During this delay, the Mains LED flashes in red.

Overvoltage enable

> Volt enable
Enable enable disable

Overvoltage setpoint

> Volt SP
0 450 999

Undervoltage delay

< Volt Delay
0 1 99

Overvoltage failclass

> Volt FC
warning warning shutdown

Undervoltage enable

< Volt enable
Enable enable disable

Undervoltage setpoint

< Volt SP
0 450 999

Overvoltage delay

> Volt Delay
0 1 99

Undervoltage failclass

< Volt FC
warning warning shutdown

Overfrequency enable

> Freq enable
Enable enable disable

Overfrequency failclass

> Freq FC
warning warning shutdown

Overfrequency delay

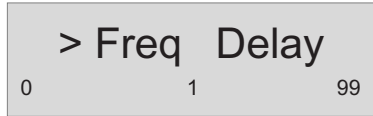

Overfrequency setpoint

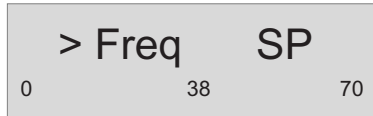

Underfrequency enable



Underfrequency failclass

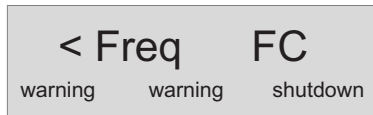

Underfrequency delay

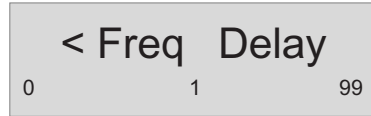

Underfrequency setpoint

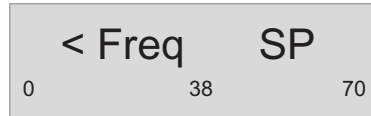

Alarm Display (pop-up window)



In case an Alarm occurs, a pop-up window will automatically be displayed for as long as the alarm is active, no matter which view is active. The flashing red alarm LED will light up. The alarm icons will be shown together with an acknowledgement check-box. Push the ENTER button to acknowledge the alarm. When the alarm has been acknowledged, a V-marking will appear in the check-box and the red alarm LED will light up continuously.



An alarm should always be acknowledged before solving the problem that causes the alarm.

The Alarm Display can always be left by pushing the BACK button.

If more than one alarm comes up, it's possible to scroll through the alarm messages with the UP and DOWN pushbuttons. The newest alarm will be placed at the bottom of the list (meaning that the older alarm stays at the display when a newer alarm comes up).

If one or more than one alarm is present, an arrow at the right of the display will be shown.

Following general groups of Alarms exist:

- Warning: Alarm LED lights up + Alarm pop-up appears on the display + Alarm relay is empowered (if configured)
- Trip of GB: 'Warning' actions + Generator Contactor opens
- Trip and Stop: 'Trip of GB' actions + unit stops after Cooldown
- Shutdown: 'Trip of GB' actions + unit stops immediately

List of possible alarms:

LOW OIL PRESSURE



HIGH COOLANT TEMPERATURE



CHARGING ALTERNATOR

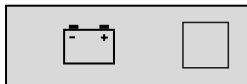

LOW FUEL LEVEL

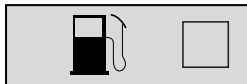

LOW COOLANT LEVEL

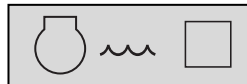

GENERATOR OVERVOLTAGE



GENERATOR UNDER-VOLTAGE



GENERATOR OVER-FREQUENCY

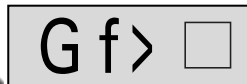

GENERATOR UNDER-FREQUENCY



SERVICE TIMER 1

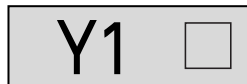

SERVICE TIMER 2

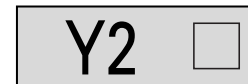

ENGINE ALARM



EMERGENCY STOP



START FAILURE



STOP FAILURE



HZ/V FAILURE



OIL LEVEL



OIL TEMPERATURE



LOG list

The unit will keep an event log of the latest 30 events.

Events are:

- shutdowns
- service timer 1/2 reset

Together with each event, the real time of the event will be stored.

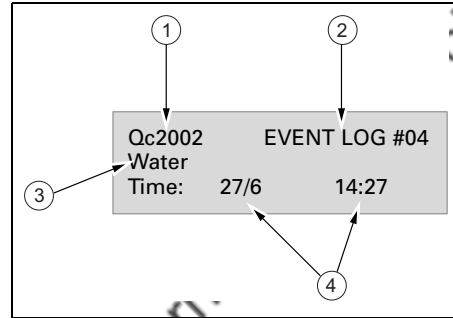

- 1 Controller type
- 2 Event number
- 3 Event
- 4 Date and hour of the event

Fail classes

All the activated alarms of the Qc2002™ have their own pre-defined fail class.

All alarms are enabled according to one of these three statuses:

- disabled alarm, no supervision of alarm (OFF).
- enabled alarm, supervision of alarm all the time (ON).
- running alarm, only supervision when the machine is running (RUN).

Output terminal board

The output terminal board option is situated below the control and indicator panel.

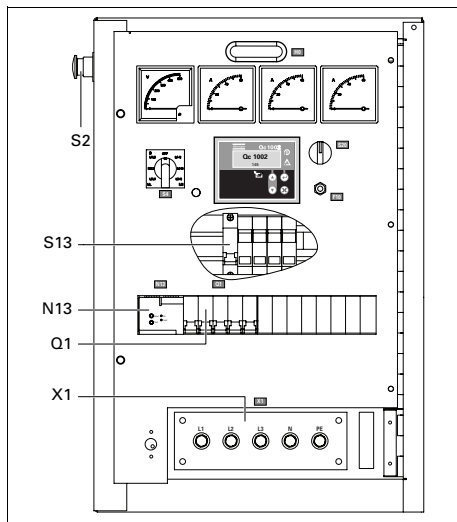

S2 Emergency stop button

Push the button to stop the generator in case of an emergency. When the button is pressed, it must be unlocked, by turning it anti-clockwise, before the generator can be restarted. The emergency stop button can be secured in the locked position with the key, to avoid unauthorized use.

Q1 Main circuit breaker

Interrupts the power supply to X1 when a short-circuit occurs at the load side, or when the earth leak detector (30 mA) or the overcurrent protection (QAS 30: 50 A, QAS 40: 63 A) is activated or when the shunt trip is energized. It must be reset manually after eliminating the problem.

X1 Main power supply (400 V AC)

Terminals L1, L2, L3, N (= neutral) and PE (= earthing), hidden behind the control panel door and behind a small transparent door.

N13 Earth leak detector

Detects and indicates an earth fault current and activates the main circuit breaker Q1. The detection level can be set at 0.03 A fixed with instantaneous trip but can also be adjusted between 0.1 A and 1 A with time delayed (0 - 0.5 sec) trip. N13 has to be reset manually after eliminating the problem (reset button marked R). It can be overridden by means of the earth leak switch (S13, labelled IAN) but has to be tested monthly (by pushing test button T).

S13 Lock-out switch for earth fault protection (N13)

This switch is located inside the cubicle and is labelled IAN.

Position O: No de-energising of the main circuit breaker Q1 when an earth fault occurs.

Position I: De-energising of the main circuit breaker Q1 when an earth fault occurs.



Position O will only be used in conjunction with an external earth fault protection unit (e.g. integrated in a distribution board).

If S13 is in position O, proper earthing is of the utmost importance for the safety of the user. Eliminating any earth fault protection can lead to serious injury or even death for anybody touching the unit or the load.

Spillage free

A Spillage free skid with forklift slots allows the customer to transport the generator easily with a forklift.

It avoids accidental spilling of engine fluids.

Electronic speed regulator

The electronic speed regulator makes sure that the output frequency of the generator is fixed (50 Hz/60 Hz), independent of the amount of load.

Operating instructions



In your own interest, always strictly observe all relevant safety instructions.

Do not operate the generator in excess of the limitations mentioned in the Technical Specifications.

Local rules concerning the setting up of low voltage power installations (below 1000 V) must be respected when connecting site distribution panels, switch gear or loads to the generator.

At each start-up and at any time a new load is connected, the earthing of the generator must be verified. Earthing must be done either by the earthing rod or, if available, by an existing suitable earthing installation. The protective system against excessive contact voltage is not effective unless a suitable earthing is made.

The generator is wired for a TN-system to IEC 364-3, i.e. one point in the power source directly earthed - in this case the neutral. The exposed conductive parts of the electric installation must be directly connected to the functional earth.

If operating the generator in another power system, e.g. an IT-system, other protective devices required for these types must be installed. In any case only a qualified electrician is authorized to remove the connection between the neutral (N) and earth terminals in the terminal box of the alternator.

Installation

- Place the generator on a horizontal, even and solid floor.
- The generator should be kept with the doors closed, in order to avoid the ingress of water and dust. Dust ingress reduces the lifetime of filters and may reduce your generator's performance.
- Check that the engine exhaust is not directed towards people. If the generator is operated indoors, install an exhaust pipe of sufficient diameter to duct the engine exhaust towards the outside. Check for sufficient ventilation so that the cooling air is not recirculated. If necessary, consult Atlas Copco.
- Leave enough space for operation, inspection and maintenance (at least 1 meter at each side).
- Check that the inner earthing system is in compliance with the local legislation.
- Use coolant for the engine cooling system. Refer to the Engine instruction book for the proper coolant mixture.

- Check the tightness of the bolts and nuts.
- Install the earthing rod as near as possible to the generator and measure its diffusion resistance (max. 1 kΩ) in order not to have a contact voltage higher than 25 V at 30 mA leakage current.
- Check that the cable end of the earthing rod is connected to the earth terminal.

Connecting the generator

Precautions for non-linear and sensitive loads



Non-linear loads draw currents with high contents in harmonics, causing distortion in the wave form of the voltage generated by the alternator.

The most common non-linear, 3-phase loads are thyristor/rectifier-controlled loads, such as convertors supplying voltage to variable speed motors, uninterruptable power supplies and Telecom supplies. Gas-discharge lighting arranged in single-phase circuits generate high 3rd harmonics and risk for excessive neutral current.

Loads most sensitive to voltage distortion include incandescent lamps, discharge lamps, computers, X-ray equipment, audio amplifiers and elevators.

Consult Atlas Copco for measures against the adverse influence of non-linear loads.

Quality, minimum section and maximum length of cables

The cable connected to the terminal board of the generator must be selected in accordance with local legislation. The type of cable, its rated voltage and current carrying capacity are determined by installation conditions, stress and ambient temperature. For flexible wiring, rubber-sheathed, flexible core conductors of the type H07 RN-F (Cenelec HD.22) or better must be used.

The following table indicates the maximum allowable 3-phase currents (in A), in an ambient temperature of 40°C, for cable types (multiple and single core PVC insulated conductors and H07 RN-F multiple core conductors) and wire sections as listed, in accordance with VDE 0298 installation method C3. Local regulations remain applicable if they are stricter than those proposed below.

| Wire section (mm ²) | Max. current (A) | | |
|------------------------------------|------------------|-------------|----------|
| | Multiple core | Single core | H07 RN-F |
| 2.5 | 22 | 25 | 21 |
| 4 | 30 | 33 | 28 |
| 6 | 38 | 42 | 36 |
| 10 | 53 | 57 | 50 |
| 16 | 71 | 76 | 67 |
| 25 | 94 | 101 | 88 |
| 35 | 114 | 123 | 110 |
| 50 | 138 | 155 | 138 |
| 70 | 176 | 191 | 170 |
| 95 | 212 | 228 | 205 |

The lowest acceptable wire section and the corresponding maximum cable or conductor length for multiple core cable or H07 RN-F, at rated current (20 A), for a voltage drop e lower than 5% and at a power factor of 0.80, are respectively 2.5 mm² and 144 m. In case electric motors must be started, oversizing the cable is advisable.

The voltage drop across a cable can be determined as follows:

$$e = \frac{\sqrt{3} \cdot I \cdot L \cdot (R \cdot \cos \phi + X \cdot \sin \phi)}{1000}$$

e = Voltage drop (V)

I = Rated current (A)

L = Length of conductors (m)

R = Resistance (Ω/km to VDE 0102)

X = Reactance (Ω/km to VDE 0102)

Connecting the load

Site distribution panel

If outlet sockets are provided, they must be mounted on a site distribution panel supplied from the terminal board of the generator and in compliance with local regulations for power installations on building sites.

Protection



For safety reasons, it is necessary to provide an isolating switch or circuit breaker in each load circuit. Local legislation may impose the use of isolating devices which can be locked.

- Check whether frequency, voltage and current comply with the ratings of the generator.
- Provide for the load cable, without excessive length, and lay it out in a safe way without forming coils.
- Open the door of the control and indicator panel and the transparent door in front of the terminal board X1.
- Provide the wire ends with cable lugs suited for the cable terminals.
- Loosen the cable clamp and push the wire ends of the load cable through the orifice and clamp.

- Connect the wires to the proper terminals (L1, L2, L3, N and PE) of X1 and tighten the bolts securely.
- Tighten the cable clamp.
- Close the transparent door in front of X1.

Before starting

- With the generator standing level, check the engine oil level and top up if necessary. The oil level must be near to, but not exceed the high mark on the engine oil level dipstick.
- Check the coolant level in the expansion tank of the engine cooling system. The coolant level must be near to the FULL mark. Add coolant if necessary.
- Drain any coolant and sediment from the fuel pre-filter. Check the fuel level and top up if necessary. It is recommended to fill the tank after the day's operation to prevent coolant damp in a nearby empty tank from condensing.
- Check the vacuum indicator of the air filter. If the red part shows completely, replace the filter element.
- Press the vacuator valve of the air filter to remove dust.
- Check the generator for leakage, tightness of wire terminals, etc. Correct if necessary.
- Check that fuse F10 has not tripped and that the emergency stop is in the OUT position.
- Check that the load is switched off.
- Check that circuit breaker Q1 is switched off.
- Check that the earth fault protection (N13) has not tripped (reset if necessary).

Operating Qc1002™

Starting Qc1002™

To start up the unit locally, proceed as follows:

- Switch on the battery switch, if applicable.
- Switch off circuit breaker Q1. This is not necessary when a plant contactor is installed between Q1 and the load.
- Put the starter switch S20 in position I (ON). The unit starts a preheating cycle which takes 12 seconds.
- After the preheating period, the unit will start. The starting attempt will take maximum 12 seconds.
- Switch on circuit breaker Q1.

To start up the unit from a remote location, proceed as follows:

- Put the starter switch S20 in position  .
- Switch on circuit breaker Q1.
- Put the remote start/stop switch in position start. The unit starts a preheating cycle which takes 12 seconds.
- After the preheating period, the unit will start. The starting attempt will take maximum 12 seconds.
- An external contactor can be connected and controlled by the Qc1002™.

During operation Qc1002™

Following points should be carried out regularly:

- Check the engine gauges and the lamps for normal readings.



Avoid to let the engine run out of fuel. If it happened, priming will speed up the starting.

- Check for leakage of oil, fuel or coolant.
- Avoid long low-load periods (< 30%). In this case, an output drop and higher oil consumption of the engine could occur.
- Check, by means of the generator gauges, that the voltage between the phases is identical and that the rated current in the third phase (L3) is not exceeded.
- When single-phase loads are connected to the generator output terminals, keep all loads well-balanced.

If circuit breakers are activated during operation, switch off the load and stop the generator. Check and, if necessary, decrease the load.



The generator's doors may only remain opened for short periods during operation, to carry out checks for example.

Stopping Qc1002™

To stop the unit locally, proceed as follows:

- Switch off the load.
- Switch off circuit breaker Q1.
- Let the engine run for about 5 minutes.
- Stop the engine by putting the starter switch S20 in position O.
- Lock the side doors and the door of the indicators and control panel to avoid unauthorized access.

To stop the unit when the starter switch is in position , proceed as follows:

- Switch off the load.
- Stop the engine by putting the remote start/stop switch in position stop or by putting the starter switch S20 in position O.
- Cooldown period default 15 sec.
- Lock the side doors and the door of the indicators and control panel to avoid unauthorized access.

Operating Qc2002™

Starting Qc2002™

To start up the unit locally, proceed as follows:

- Switch on the battery switch.
- Switch off circuit breaker Q1. This is not necessary when a plant contactor is installed between Q1 and the load.
- Put the starter switch S20 in position I (ON). Voltage is applied to the Qc2002™ module.
- The unit can be started manually by pressing the START button on the Qc2002™ module.
- The unit starts a preheating cycle which takes 12 seconds.
- After the preheating period, the unit will start. The starting attempt will take maximum 12 seconds.
- Switch on circuit breaker Q1 in case no contactor is installed.

To start up the unit from a remote location, proceed as follows:

- Put the starter switch S20 in position I (ON). Voltage is applied to the Qc2002™ module.
- Switch on circuit breaker Q1.
- For remote start:
 - Put the unit in Island mode. Push the AUTOMATIC button. Use an external switch to start the machine.
- or
- Put the unit in AMF mode. Push the AUTOMATIC button. The machine will start automatically when Mains fails.
- The unit starts a preheating cycle which takes 12 seconds.
- After the preheating period, the unit will start. The starting attempt will take maximum 12 seconds.

During operation Qc2002™

Following points should be carried out regularly:

- Check the engine gauges and the lamps for normal readings.



Avoid to let the engine run out of fuel. If it happened, priming will speed up the starting.

Check for leakage of oil, fuel or coolant.

- Avoid long low-load periods (< 30%). In this case, an output drop and higher oil consumption of the engine could occur.
- Check, by means of the generator gauges, that the voltage between the phases is identical and that the rated current in the third phase (L3) is not exceeded.
- When single-phase loads are connected to the generator output terminals, keep all loads well-balanced.

If circuit breakers are activated during operation, switch off the load and stop the generator. Check and, if necessary, decrease the load.



The generator's doors may only remain opened for short periods during operation, to carry out checks for example.

Stopping Qc2002™

To stop the unit , proceed as follows:

- Switch off the load.
 - Switch off circuit breaker Q1.
 - Let the engine run for about 5 minutes.
 - Stop the engine by using the STOP button on the Qc2002™ module.
 - Put the starter switch S20 in position O (OFF) to shut down the voltage apply towards the Qc2002™ module.
 - Lock the side doors and the door of the indicators and control panel to avoid unauthorized access.
- Cooldown period default 15 sec.
 - Put the starter switch S20 in position O (OFF) to shut down the voltage apply towards the Qc2002™ module.
 - Lock the side doors and the door of the indicators and control panel to avoid unauthorized access.

To stop the unit when the Qc2002™ module is in AUTOMATIC operation mode, proceed as follows:

- Switch off the load.
- For remote start:
- When operating in Island mode, use the external switch to stop the machine.
- When operating in AMF mode, the machine will automatically stop when the Mains returns.



When the unit is stopped with the STOP button in Automatic operation, it will automatically go to Manual Mode.

Maintenance

Maintenance schedule



Before carrying out any maintenance activity, check that the start switch is in position O and that no electrical power is present on the terminals.

| Maintenance schedule | Daily | Every 500 hours or yearly | Every 1000 hours or 24 months |
|---|-------|---------------------------|-------------------------------|
| Service pak | - | 2912 6391 05 | 2912 6392 06 |
| <i>For the most important subassemblies, Atlas Copco has developed service kits that combine all wear parts. These service kits offer you the benefits of genuine parts, save on administration costs and are offered at reduced price, compared to the loose components. Refer to the parts list for more information on the contents of the service kits.</i> | | | |
| Check for air, fuel, coolant and oil leakage | X | X | X |
| Check oil and coolant level | X | X | X |
| Check or drain water in fuelfilter/waterseparator | X | X | X |
| Clean air cleaner and dust bowl | X | X | X |
| Check vacuum indicator | X | X | X |
| Visual walk around the unit | X | X | X |
| Replace engine oil (1) | | X | X |
| Replace engine oil filter (1) | | X | X |
| Check/clean radiator/cooler fins | | X | X |
| Check tension and condition of the drive belt/Replace | | X | X |
| Grease door hinges and locks | | X | X |
| Replace fuel filter element | | X | X |
| Replace fuel prefilter element | | X | X |
| Check electrolyte level and terminals of battery | | X | X |
| Check engine mounts | | X | X |

| | | | |
|---|---|---|---|
| Check crankcase ventilation system | | X | X |
| Check condition of cooling fan assembly | | X | X |
| Pressure test cooling system | | X | X |
| Check engine electrical ground connection | | X | X |
| Replace air filter element (2) | | X | X |
| Measure alternator insulation resistance | | X | X |
| Check glycol level in coolant (4) | | X | X |
| Check PH level of engine coolant (4) | | X | X |
| Monitor Insulation Resistance of the main alternator | | X | X |
| Replace safety cartridge | | | X |
| Check and adjust engine inlet and outlet valves (3) | | | X |
| Check alternator and starter motor | | | X |
| Check electrical system for security of cables and wear | | | X |
| Test thermostats | | | X |
| Test glow plugs | | | X |
| Inspection by Atlas Copco Service technician |  | Generators in standby application have to be tested on a regular basis. At least once a month the engine should run for minimum 30 minutes at a high load (50% - 70%) that the engine reaches its operating temperature. | |

Notes:

In highly dusty environments, these service intervals do not apply. Check and/or replace filters and clean radiator on a regular basis.

- (1) During engine break-in, change the oil and oil filter for the first time after max. 50 hours of operation.
- (2) Air filter should be replaced sooner when the unit is operating in a dusty environment.
- (3) Rocker cover gaskets can be re-used after valve clearance.
- (4) Adjust/replace coolant as necessary.

Engine maintenance

Refer to the engine's operator manual for full maintenance, including instructions for changing the oil and coolant and replacing the fuel, oil and air filters.

(*) Measuring the alternator insulation resistance

A 500 V megger is required to measure the alternator insulation resistance.

If the N-terminal is connected to the earthing system, it must be disconnected from the earth terminal. Disconnect the AVR.

Connect the megger between the earth terminal and terminal L1 and generate a voltage of 500 V. The scale must indicate a resistance of at least 5 MΩ.

Refer to the alternator operating and maintenance instructions for more details.

Engine oil specifications



It is strongly recommended to use Atlas Copco branded lubrication oils.

High quality, mineral, hydraulic or synthesized hydrocarbon oil with rust and oxidation inhibitors, anti-foam and anti-wear properties is recommended.

The viscosity grade should correspond to the ambient temperature and ISO 3448, as follows.

| Engine | Type of lubricant |
|--|-------------------|
| between 0°C (32°F) and 40°C (104°F) | PAROIL 15W40 |
| between -25°C (-13°F) and 40°C (104°F) | PAROIL 5W40 |



Never mix synthetic with mineral oil.

Remark:

When changing from mineral to synthetic oil (or the other way around), you will need to do an extra rinse.

After doing the complete change procedure to synthetic oil, run the unit for a few minutes to allow good and complete circulation of the synthetic oil. Then drain the synthetic oil again and fill again with new synthetic oil. To set correct oil levels, proceed as in normal instruction.

Specifications PAROIL

PAROIL from Atlas Copco is the ONLY oil tested and approved for use in all engines built into Atlas Copco compressors and generators.

Extensive laboratory and field endurance tests on Atlas Copco equipment have proven PAROIL to match all lubrication demands in varied conditions. It meets stringent quality control specifications to ensure your equipment will run smoothly and reliably.

The quality lubricant additives in PAROIL allow for extended oil change intervals without any loss in performance or longevity.

PAROIL provides wear protection under extreme conditions. Powerful oxidation resistance, high chemical stability and rust- inhibiting additives help reduce corrosion, even within engines left idle for extended periods.

PAROIL contains high quality anti-oxidants to control deposits, sludge and contaminants that tend to build up under very high temperatures.

PAROIL's detergent additives keep sludge forming particles in a fine suspension instead of allowing them to clog your filter and accumulate in the valve/rocker cover area.

PAROIL releases excess heat efficiently, whilst maintaining excellent bore-polish protection to limit oil consumption.

PAROIL has an excellent Total Base Number (TBN) retention and more alkalinity to control acid formation.

PAROIL prevents Soot build-up.

PAROIL is optimized for the latest low emission EURO -3 & -2, EPA TIER II & III engines running on low sulphur diesel for lower oil and fuel consumption.

PAROIL 5W40 and PAROIL 15W40

Synthetic engine oil PAROIL 5W40

PAROIL 5W40 is a Synthetic ultra high performance diesel engine oil with a high viscosity- index. Atlas Copco PAROIL 5W40 is designed to provide excellent lubrication from start-up in temperatures as low as -25°C (-13°F).

| | Liter | US gal | Imp gal | cu.ft | Order number |
|--------|-------|--------|---------|-------|--------------|
| can | 5 | 1.3 | 1.1 | 0.175 | 1604 6060 01 |
| barrel | 210 | 55.2 | 46 | 7.35 | 1604 6059 01 |

Mineral engine oil PAROIL 15W40

PAROIL 15W40 is a mineral based high performance diesel engine oil with a high viscosity- index. Atlas Copco PAROIL 15W40 is designed to provide a high level of performance and protection in standard ambient conditions as from -15°C (5°F).

| | Liter | US gal | Imp gal | cu.ft | Order number |
|--------|-------|--------|---------|-------|--------------|
| can | 5 | 1.3 | 1.1 | 0.175 | 1615 5953 00 |
| can | 20 | 5.3 | 4.4 | 0.7 | 1615 5954 00 |
| barrel | 210 | 55.2 | 46 | 7.35 | 1615 5955 00 |

Engine oil level check

Consult the Engine Operation Manual for the oil specifications, viscosity recommendations and oil change intervals.

For intervals, see section "Maintenance schedule" on page 42.

Check engine oil level according to the instructions in the Engine Operation Manual and if necessary top up with oil.

Engine oil and oil filter change

See section "Maintenance schedule" on page 42.

Engine coolant specifications



Never remove the cooling system filler cap while coolant is hot.

The system may be under pressure. Remove the cap slowly and only when coolant is at ambient temperature. A sudden release of pressure from a heated cooling system can result in personal injury from the splash of hot coolant.

It is strongly recommended to use Atlas Copco branded coolant.

The use of the correct coolant is important for good heat transfer and protection of liquid-cooled engines. Coolants used in these engines must be mixtures of good quality water (distilled or de-ionised), special coolant additives and if necessary freeze protection. Coolant that is not to manufacturer's specification will result in mechanical damage of the engine.

The freezing point of the coolant must be lower than the freezing point that can occur in the area. The difference must be at least 5°C (41°F). If the coolant freezes, it may crack the cylinder block, radiator or coolant pump.

Consult the engine's operation manual and follow the manufacturer's directions.



Never mix different coolants and mix the coolant components outside the cooling system.

Specifications PARCOOL EG

PARCOOL EG is the only coolant that has been tested and approved by all engine manufacturers currently in use in Atlas Copco compressors and generators.

Atlas Copco's PARCOOL EG extended life coolant is the new range of organic coolants purpose designed to meet the needs of modern engines. PARCOOL EG can help prevent leaks caused by corrosion. PARCOOL EG is also fully compatible with all sealants and gasket types developed to join different materials used within an engine.

PARCOOL EG is a ready to use Ethylene Glycol based coolant, premixed in an optimum 50/50 dilution ratio, for antifreeze protection guaranteed to -40°C (-40°F).

Because PARCOOL EG inhibits corrosion, deposit formation is minimized. This effectively eliminates the problem of restricted flow through the engine coolant ducts and the radiator, minimizing the risk for engine overheating and possible failure.

It reduces water pump seal wear and has excellent stability when subjected to sustained high operating temperatures.

PARCOOL EG is free of nitride and amines to protect your health and the environment. Longer service life reduces the amount of coolant produced and needing disposal to minimise environmental impact.

| | Liter | US gal | Imp gal | cu.ft | Order number |
|--------|-------|--------|---------|-------|--------------|
| can | 5 | 1.3 | 1.1 | 0.175 | 1604 5308 00 |
| can | 20 | 5.3 | 4.4 | 0.7 | 1604 5307 01 |
| barrel | 210 | 55.2 | 46 | 7.35 | 1604 5306 00 |

To ensure protection against corrosion, cavitation and formation of deposits, the concentration of the additives in the coolant must be kept between certain limits, as stated by the manufacturer's guidelines. Topping up the coolant with water only, changes the concentration and is therefore not allowed.

Liquid-cooled engines are factory-filled with this type of coolant mixture.

Coolant check

Monitoring coolant condition

In order to guarantee the lifetime and quality of the product, thus to optimise engine protection, regular coolant-condition-analysis is advisable.

The quality of the product can be determined by three parameters.

Visual check

- Verify the outlook of the coolant regarding colour and make sure that no loose particles are floating around.

pH measurement

- Check the pH value of the coolant using a pH-measuring device.
- The pH-meter can be ordered from Atlas Copco with part number 2913 0029 00.
- Typical value for EG = 8.6.
- If the pH-level is below 7 or above 9.5, the coolant should be replaced.

Glycol concentration measurement

- To optimise the unique engine protection features of the PARCOOL EG the concentration of the Glycol in the water should be always above 33 vol.%.
- Mixtures with more than 68 vol.% mix ratio in water are not recommended, as this will lead to high engine operating temperatures.

- A refractometer can be ordered from Atlas Copco with part number 2913 0028 00.



In case of a mix of different coolant products this type of measurement might provide incorrect values.

Topping up of coolant

- Verify if the engine cooling system is in a good condition (no leaks, clean,...).
- Check the condition of the coolant.
- If the condition of the coolant is outside the limits, the complete coolant should be replaced (see section "Replacing the coolant").
- Always top-up with PARCOOL EG.
- Topping up the coolant with water only, changes the concentration of additives and is therefore not allowed.

Replacing the coolant

Drain

- Completely drain the entire cooling system.
- Used coolant must be disposed or recycled in accordance with laws and local regulations.

Flush

- Flush twice with clean water. Used coolant must be disposed or recycled in accordance with laws and local regulations.
- From the Atlas Copco Instruction book, determine the amount of PARCOOL EG required and pour into the radiator top tank.
- It should be clearly understood that the risk for contamination is reduced in case of proper cleaning.
- In case a certain content of 'other' coolant remains in the system, the coolant with the lowest properties influences the quality of the 'mixed' coolant.

Fill

- To assure proper operation and the release of trapped air, run the engine until normal engine operation temperature is reached. Turn off the engine and allow to cool.
- Recheck coolant level and add if necessary.

Storage of the generator

Storage

- Store the generator in a dry, frost-free room which is well ventilated.
- Run the engine regularly, e.g. once a week, until it is warmed up. If this is impossible, extra precautions must be taken:
 - Consult the engine's operator manual.
 - Remove the battery. Store it in a dry, frost-free room. Keep the battery clean and its terminals lightly covered with petroleum jelly. Recharge the battery regularly.
 - Clean the generator and protect all electrical components against moisture.
 - Place silica gel bags, VCI paper (Volatile Corrosion Inhibitor) or another drying agent inside the generator and close the doors.
 - Stick sheets of VCI paper with adhesive tape on the bodywork to close off all openings.
 - Wrap the generator, except the bottom, with a plastic bag.

Preparing for operation after storage

Before operating the generator again, remove the wrapping, VCI paper and silica gel bags and check the generator thoroughly (go through the checklist "Before starting" on page 38).

- Consult the engine's operator manual.
- Check that the insulation resistance of the generator exceeds 5 MΩ.
- Replace the fuel filter and fill the fuel tank. Vent the fuel system.
- Reinstall and connect the battery, if necessary after being recharged.
- Submit the generator to a test run.

Checks and trouble shooting



Never perform a test run with connected power cables. Never touch an electrical connector without a voltage check.

When a failure occurs, always report what you experienced before, during and after the failure. Information with regard to the load (type, size, power factor, etc.), vibrations, exhaust gas colour, insulation check, odours, output voltage, leaks and damaged parts, ambient temperature, daily and normal maintenance and altitude might be helpful to quickly locate the problem. Also report any information regarding the humidity and location of the generator (e.g. close to sea).

Checking voltmeter P4

- Put a voltmeter in parallel with voltmeter P4 on the control panel.
- Check that the read-out of both voltmeters is the same.
- Stop the generator and disconnect one terminal.
- Check that the internal resistance of the voltmeter is high.

Checking ammeters P1, P2 and P3

- Measure the outgoing current during the load, by means of a clamp-on probe.
- Compare the measured current with the current indicated on ammeter. Both readings should be the same.



Ammeter P1, P2, P3 and voltmeter P4 are only provided on units with Qc1002™ controller.

Machine Verhuur Oosterwolde

Alternator troubleshooting

| <i>Symptom</i> | <i>Possible cause</i> | <i>Corrective action</i> |
|---|---------------------------------------|---|
| <i>Alternator gives 0 Volt</i> | Blown fuse. | Replace fuse. |
| | No residual voltage. | Excite the alternator by applying a 12V battery voltage with a 30 W resistor in series on the + and - terminals of the electronic regulator, respecting the polarities. |
| <i>After being excited the alternator still gives 0 Volt.</i> | Connections are interrupted. | Check connection cables, measure winding resistances and compare with values mentioned in the alternator manual. |
| <i>Low voltage at no load</i> | Voltage potentiometer out of setting. | Reset voltage. |
| | Intervention of protection. | Check frequency/voltage regulator. |
| | Winding failure. | Check windings. |
| <i>High voltage at no load</i> | Voltage potentiometer out of setting. | Reset voltage. |
| | Failed regulator. | Substitute regulator. |
| <i>Lower than rated voltage at load</i> | Voltage potentiometer out of setting. | Reset voltage potentiometer. |
| | Intervention by protection. | Current too high, power factor lower than 0.8; speed lower than 10% of rated speed. |
| | Failed regulator. | Substitute regulator. |
| | Rotating bridge failure. | Check diodes, disconnect cables. |
| <i>Higher than rated voltage at load</i> | Voltage potentiometer out of setting. | Reset voltage potentiometer. |
| | Failed regulator. | Substitute regulator. |
| <i>Unstable voltage</i> | Speed variation in engine. | Check regularity of rotation. |
| | Regulator out of setting. | Regulate stability of regulator by acting on STABILITY potentiometer. |

Engine trouble shooting

The table below gives an overview of the possible engine problems and their possible causes.

The starter motor turns the engine too slowly

- Battery capacity too low.
- Bad electrical connection.
- Fault in starter motor.
- Wrong grade of lubricating oil.

The engine does not start or is difficult to start

- Starter motor turns engine too slowly.
- Fuel tank empty.
- Fault in fuel control solenoid.
- Restriction in a fuel pipe.
- Fault in fuel lift pump.
- Dirty fuel filter element.
- Air in fuel system.
- Fault in atomisers.
- Cold start system used incorrectly.
- Fault in cold start system.
- Restriction in fuel tank vent.
- Wrong type or grade of fuel used.
- Restriction in exhaust pipe.

Not enough power

- Restriction in a fuel pipe.
- Fault in fuel lift pump.
- Dirty fuel filter element.
- Restriction in air filter/cleaner or induction system.
- Air in fuel system.
- Fault in atomisers or atomisers of an incorrect type.
- Restriction in fuel tank vent.
- Wrong type or grade of fuel used.
- Restricted movement of engine speed control.
- Restriction in exhaust pipe.
- Engine temperature is too high.
- Engine temperature is too low.

Misfire

- Restriction in a fuel pipe.
- Fault in fuel lift pump.
- Dirty fuel filter element.
- Air in fuel system.
- Fault in atomisers or atomisers of an incorrect type.
- Fault in cold start system.
- Engine temperature is too high.
- Incorrect valve tip clearances.

The pressure of the lubricating oil is too low

- Wrong grade of lubricating oil.
- Not enough lubricating oil in sump.
- Defective gauge.
- Dirty lubricating oil filter element.

High fuel consumption

- Restriction in air filter/cleaner or induction system.
- Fault in atomisers or atomisers of an incorrect type.
- Fault in cold start system.
- Wrong type or grade of fuel used.
- Restricted movement of engine speed control.
- Restriction in exhaust pipe.
- Engine temperature is too low.
- Incorrect valve tip clearances.

Black exhaust smoke

- Restriction in air filter/cleaner or induction system.
- Fault in atomisers or atomisers of an incorrect type.
- Fault in cold start system.
- Wrong type or grade of fuel used.
- Restriction in exhaust pipe.
- Engine temperature is too low.
- Incorrect valve tip clearances.
- Engine overload.

Blue or white exhaust smoke

- Wrong grade of lubricating oil.
- Fault in cold start system.
- Engine temperature is too low.

The engine knocks

- Fault in fuel lift pump.
- Fault in atomisers or atomisers of an incorrect type.
- Fault in cold start system.
- Wrong type or grade of fuel used.
- Engine temperature is too high.
- Incorrect valve tip clearances.

The engine runs erratically

- Fault in fuel control.
- Restriction in a fuel pipe.
- Fault in fuel lift pump.
- Dirty fuel filter element.
- Restriction in air filter/cleaner or induction system.
- Air in fuel system.
- Fault in atomisers or atomisers of an incorrect type.
- Fault in cold start system.
- Restriction in fuel tank vent.
- Restricted movement of engine speed control.
- Engine temperature is too high.
- Incorrect valve tip clearances.

Vibration

- Fault in atomisers or atomisers of an incorrect type.
- Restricted movement of engine speed control.
- Engine temperature is too high.
- Fan damaged.
- Fault in engine mounting or flywheel housing.

The pressure of the lubricating oil is too high

- Wrong grade of lubricating oil.
- Defective gauge.

The engine temperature is too high

- Restriction in air filter/cleaner or induction system.
- Fault in atomisers or atomisers of an incorrect type.
- Fault in cold start system.
- Restriction in exhaust pipe.
- Fan damaged.
- Too much lubricating oil in sump.
- Restriction in air or coolant passages of radiator.
- Insufficient coolant in system.

Crankcase pressure

- Restriction in breather pipe.
- Vacuum pipe leaks or fault in exhauster.

Bad compression

- Restriction in air filter/cleaner or induction system.
- Incorrect valve tip clearances.

The engine starts and stops

- Dirty fuel filter element.
- Restriction in air filter/cleaner or induction system.
- Air in fuel system.

The engine shuts down after approx. 15 sec.

- Bad connection towards oil pressure switch/coolant temperature switch.

Options available for QAS 30 and QAS 40 units

Circuit diagrams

The engine control circuit diagrams and the power circuit diagrams for the standard QAS 30 and QAS 40 units:

Power circuit

Unit

Circuit

QAS 30-40 Kd

9822 0992 70

Engine circuit

Unit

Circuit

QAS 30-40 Kd

9822 0992 77

Controller circuit

Unit

Circuit

QAS 30-40 Kd Qc1002™

9822 0992 78

QAS 30-40 Kd Qc2002™

9822 0992 79

Overview of the electrical options

The following electrical options are available for the QAS 30 and QAS 40 units:

- Automatic battery charger
- Battery switch
- Engine coolant heater
- Outlet sockets (S)
- Low voltage (LV)
- IT-relay
- “Electricité de France” (EDF)
- Integrated spark arrestor
- COSMOS™ retrofit kit

Description of the electrical options

Automatic battery charger

The automatic battery charger charges the battery completely and is disconnected once the unit starts up.

Besides the output terminals (secondary side) the automatic battery charger has a trim potentiometer for setting of the output voltage. By means of an insulated slotted screwdriver or adjusting pin the output voltage can be set in the range 23.5-27.5 V respectively 11.8-13.8 V.

The LED on the front indicates that the unit is operational.

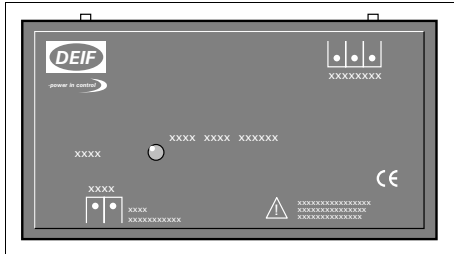

Setting:

- Lower output voltage = Counterclockwise rotation
- Higher output voltage = Clockwise rotation

To use the battery charger:

- Provide the X25 connector, located at the side of the power cubicle, with external power to use the battery charger.



The automatic battery charger is standard on units with the Qc2002™ Controller.

Battery switch

The battery switch is situated inside the sound-insulated bodywork. It allows to open or to close the electrical connection between the battery and the engine circuits.



Never turn the battery switch to OFF during operation.

Engine coolant heater

To make sure that the engine can start and accept load immediately, an external coolant heater (1000 W, 240 V) is provided which keeps the engine temperature between 38°C and 49°C.

Outlet sockets (S)

A brief description of all outlet sockets and circuit breakers provided on the generator is given hereafter:

X2 3-phase outlet socket (400 V AC)

Provides phases L1, L2 and L3, neutral and earthing.

X3 3-phase outlet socket (400 V AC)

Provides phases L1, L2 and L3, neutral and earthing.

X4 3-phase outlet socket (400 V AC)

Provides phases L1, L2 and L3, neutral and earthing.

X5 1-phase outlet socket (230 V AC)

Provides phase L3, neutral and earthing.

Q3 Circuit breaker for X3

Interrupts the power supply to X3 when a short-circuit occurs at the load side, or when the overcurrent protection (32 A) is activated. When activated, Q3 interrupts the three phases towards X3. It can be activated again after eliminating the problem.

Q4.....Circuit breaker for X4

Interrupts the power supply to X4 when a short-circuit occurs at the load side, or when the overcurrent protection (16 A) is activated. When activated, Q4 interrupts the three phases towards X4. It can be activated again after eliminating the problem.

Q5.....Circuit breaker for X5

Interrupts the power supply to X5 when a short-circuit occurs at the load side, or when the overcurrent protection (16 A) is activated. When activated, Q5 interrupts phase L3 and the neutral towards X5. It can be activated again after eliminating the problem.

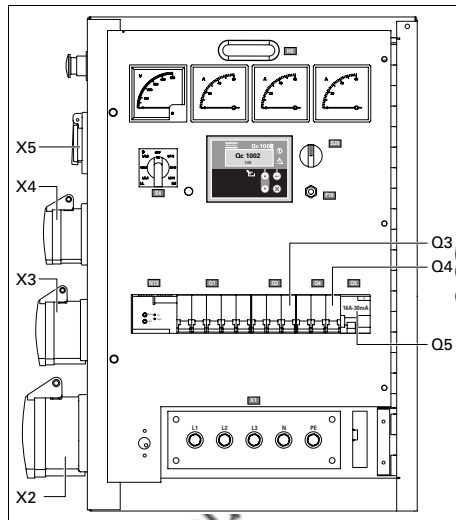

Circuit breaker Q1 does not only interrupt the power supply towards X1, but also towards X2, X3, X4 and X5.

Make sure to switch on circuit breakers Q1, Q3, Q4 and Q5 after starting the generator when power supply is done by means of X2, X3, X4 or X5.

Low voltage (LV)

The Low voltage option allows to run the unit at low voltage (= high current).



All the cables that are used must be suitable for high current.

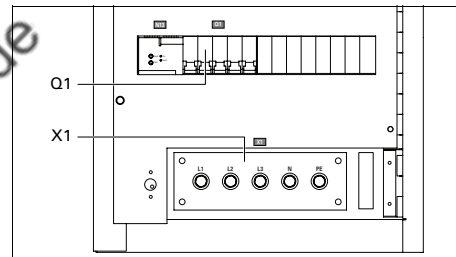

Q1.....Circuit breaker for low voltage, high current

Interrupts the low voltage power supply towards X1 when a short-circuit occurs at the load side or when the overcurrent protection (QAS 30: 50 Hz, 100 A, QAS 40: 50 Hz, 125 A) is activated. It must be reset manually after eliminating the problem.

IT-relay

The generator is wired for an IT network i.e. no supply lines of the power supply are directly earthed. A failure in insulation resulting in a too low insulation resistance, is detected by the insulation monitoring relay.



The generator shall not be operated with other networks (such as TT or TN). Doing so will cause tripping of the insulation monitoring relay.

The generator is wired for an IT network i.e. no supply lines of the power supply are directly earthed. A failure in insulation resulting in too low an insulation resistance, is detected by the insulation monitoring relay.

At each start-up and any time a new load is connected, the insulation resistance must be verified. Check for the correct setting of the insulation monitoring relay. (factory set at 13 k Ω)

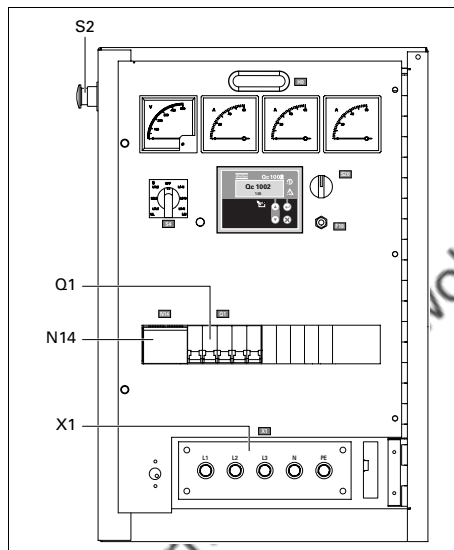

Q1 Circuit breaker for X1

Interrupts the power supply X1 when a short-circuit occurs at the load side, or when the overcurrent protection is activated. When activated, Q1 interrupts the three phases towards X1. It must be reset manually after eliminating the problem.

X1 Main power supply (400 V AC)

Terminals L1, L2, L3, N (= neutral) and PE (= earthing), hidden behind the control panel door and behind a small transparent door.

N14 Insulation monitoring relay

Checks the insulation resistance and activates Q1 when the insulation resistance is too low.

S2 Emergency stop button

Push the button to stop the generator in case of an emergency. When the button is pressed, it must be unlocked, by turning it anti-clockwise, before the generator can be restarted. The emergency stop button can be secured in the locked position with the key, to avoid unauthorized use.

“Electricité de France” (EDF)

When the EDF-option is installed, the unit operates as a standard unit when the neutral and the PE terminals are connected to each other (see figure below). In this case, an earth leakage at the side of the generator or at the side of the load will switch off the circuit breaker.

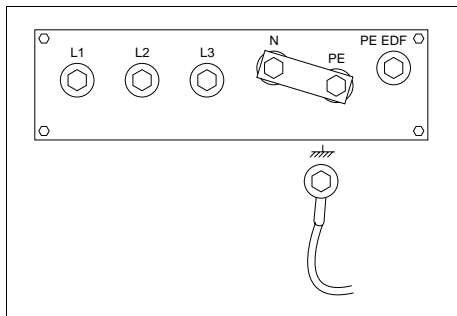

When EDF-option is installed, the unit operates as EDF-unit when the earthing, the PE and the PE EDF terminals are connected to each other (see figure below). In this case, an earth leakage at the side of the generator will switch off the circuit breaker. An earth leakage at the side of the load will not switch off the circuit breaker.

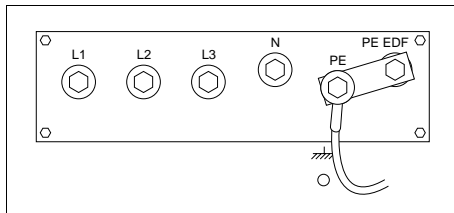

Changing the operation mode from standard unit to EDF-unit or vice versa has to be carried out by a qualified person from “Electricité de France”.

Integrated spark arrester

The integrated spark arrester option is included in the refinery equipment pack.

COSMOST™ retrofit kit

COSMOST™ is a web-based global remote monitoring system that electronically tracks every aspect of equipment from its location to its operating parameters. The Cosmos system can send e-mails or SMS messages to the contractor or owner in real time, with all critical and non-critical events and data involving your compressors and generators. It allows optimal servicing.

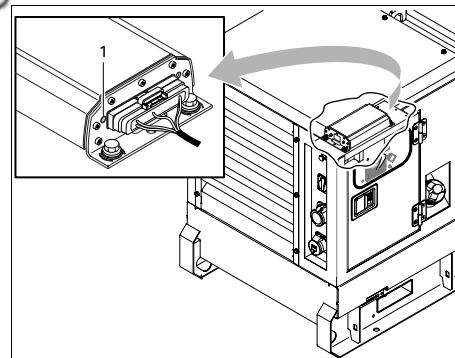

When starting up the generator, the green Power Led (1) of the Cosmos module will light up when the installation has been carried out correctly.

For information about COSMOST™, consult your local Atlas Copco dealer.

Overview of the mechanical options

The following mechanical options are available for the QAS 30 and QAS 40 units:

- External fuel tank connection (with/without quick couplings)
- Undercarriage (axle, towbar, towing eyes)

Description of the mechanical options

External fuel tank connection (with/without quick couplings)

The option external fuel tank connection allows to bypass the internal fuel tank and to connect an external fuel tank to the unit.

View outside

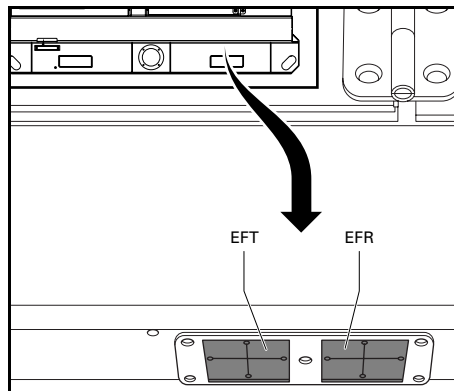

View inside

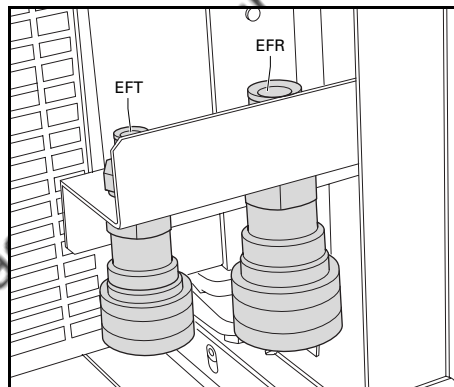

EFT | External fuel tank connection
EFR | External fuel tank return connection

When using this option, make sure to connect the fuel supply line as well as the fuel return line. Connections to fuellines ought to be air-tight to prevent air from entering the fuel system.



Position 1: Indicates that the fuel supply line to the engine is connected to the internal fuel tank.



Position closed: Indicates that the fuel supply line to the engine is closed.



Position 2: Indicates that the fuel supply line to the engine is connected to the external fuel tank.

Undercarriage (axle, towbar, towing eyes)

The undercarriage is equipped with an adjustable towbar with brakes, with DIN-eye, BNA-eye, NATO-eye, GB-eye, ITA-eye or ball coupling and with road signalisation which is approved by EC legislation.

When using this option

- Make sure that the towing equipment of the vehicle matches the towing eye before towing the generator.
- Never move the generator while electrical cables are connected to the unit.
- Always apply the hand brake when parking the generator.
- Leave enough space for operation, inspection and maintenance (at least 1 meter at each side).

To maintain the undercarriage

- Check the tightness of the towbar bolts, the axle bolts and the wheel nuts at least twice a year and after the initial 50 hours of operation.
- Grease the wheel axle suspension bearings, the drawbar to the steering gear shaft and the spindle of the brake handle at least twice a year. Use ball bearing grease for the wheel bearings and graphite grease for the drawbar and spindle.
- Check the brake system twice a year.
- Check the condition of the vibration dampers twice a year.
- Repack the wheel hub bearings once a year using grease.

Machine Verhuur Oostervolde

Technical specifications

Technical specifications for QAS 30 units

Readings on gauges

| <i>Gauge</i> | <i>Reading</i> | <i>Unit</i> |
|-----------------|-------------------|-------------|
| Ammeter L3 (P3) | Below max. rating | A |
| Voltmeter (P4) | Below max. rating | V |

Settings of switches

| <i>Switch</i> | <i>Function</i> | <i>Activates at</i> |
|----------------------------|-----------------|---------------------|
| Engine oil pressure | Shut down | 0.5 bar |
| Engine coolant temperature | Shut down | 103°C |

Specifications of the engine/alternator/unit

| | | 50 Hz | |
|----------------------------------|---|----------|--|
| <i>Reference conditions 1)</i> | Rated frequency | 50 Hz | |
| | Rated speed (optional) | 1500 rpm | |
| | Generator service duty | PRP | |
| | Absolute air inlet pressure | 100 kPa | |
| | Relative air humidity | 30% | |
| | Air inlet temperature | 25°C | |
| <i>Limitations 2)</i> | Maximum ambient temperature | 50°C | |
| | Altitude capability | 4000 m | |
| | Maximum relative air humidity | 85% | |
| | Minimum starting temperature unaided | -18°C | |
| | Minimum starting temperature aided (optional) | -25°C | |
| <i>Performance data 2) 3) 5)</i> | Rated active power (PRP) 3ph | 24.1 kW | |
| | Rated active power (PRP) 1ph | NA | |

| | |
|--|------------------|
| Rated power factor (lagging) 3ph | 0.8 cos ϕ |
| Rated power factor (lagging) 1ph | NA |
| Rated PRP power 3ph | 30.2 kVA |
| Rated PRP power 1ph | NA |
| Rated voltage 3ph line to line | 400 V |
| Rated voltage 3ph line to line lower voltage | NA |
| Rated voltage 1ph | NA |
| Rated current 3ph | 43.6 A |
| Rated current 3ph lower voltage | NA |
| Rated current 1ph | NA |
| Performance class (acc.ISO 8528-5:1993) | G2 |
| Single step load acceptance (0-PRP) | 24.1 kW |
| | 100% |
| Frequency droop (optional) | < 5% |
| | isochronous |
| Fuel consumption at no load (0%) | 1.5 kg/h |
| Fuel consumption at 50% load | 3.5 kg/h |
| Fuel consumption at 75% load | 4.7 kg/h |
| Fuel consumption at full load (100%) | 6.0 kg/h |
| Specific fuel consumption (at full load, 100%) | 0.251 kg/kWh |
| Fuel autonomy at full load with standard tank | 13.1 h |
| Fuel autonomy at full load with extended fuel tank (optional) | 36.6 h |
| Max. oil consumption at full load | 30.2 g/h |
| Maximum sound power level (LWA) measured according to 2000/14/EC OND | 91 dB(A) |
| Capacity of fuel tank | 92 l |
| Capacity of optional skid fuel tank (optional) | 257 l |
| Single step load capability (0-PRP) | 24.1 kW |
| | 100% |
| Mode of operation | PRP |
| Site | land use |
| Operation | single |
| Start-up and control mode | manual/automatic |

Application data

Alternator 4)

| | |
|---|-----------------------------|
| Start-up time | unspecified |
| Mobility/Config. acc. to ISO 8528-1:1993 (optional) | transportable/D mobile/E |
| Mounting | fully resilient |
| Climatic exposure | open air |
| Degree of protection | IP 54 |
| Status of neutral (TT or NT) | earthed |
| Status of neutral (IT) (optional) | insulated |
| Standard | IEC 34-1 ISO 8528-3 |
| Make | STAMFORD |
| Model | BCI184-G1 |
| Rated output, class H temp. rise rating type acc. ISO 8528-3 | 31.3 kVA BR |
| Degree of protection | IP 23 |
| Insulation stator class | H |
| Insulation rotor class | H |
| Number of wires | 12 |

Engine 4)

| | |
|---|-------------------------|
| Standard | ISO 3046 ISO 8528-2 |
| Type KUBOTA | V3300DI |
| Rated net output rating type acc. ISO 3046-7 production tolerance | 28.0 kW ICXN ± 5% |
| Coolant | coolant |
| Combustion system | direct injection |
| Aspiration | natural aspirated |
| Number of cylinders | 4 |
| Swept volume | 3.3 l |
| Speed governing | electronic |
| Capacity of oil sump | 13 l |
| Capacity of cooling system | 7.5 l |
| Electrical system | 12 Vdc |

| | | |
|----------------------------------|--|--------------------------|
| | Emission compliance | EU STAGE II |
| <i>Power circuit</i> | Circuit-breaker, 3ph. | |
| | Number of poles | 4 |
| | Thermal release It (thermal release is higher at 25°C) | 50 A |
| | Magnetic release Im | 3..5xIn |
| | Circuit-breaker, 3ph., lower voltage | |
| | Number of poles | NA |
| | Thermal release It | NA |
| | Magnetic release Im | NA |
| | Fault current protection | |
| | Residual current release IDn | 0.030-30 A |
| Insulation resistance (optional) | 10-100 kOhm | |
| <i>Unit</i> | Outlet sockets | domestic (1x) (optional) |
| | | 2p + PE |
| | | 16 A/230 V |
| | | CEE form (1x) |
| | | 3p + N + PE |
| | | 16 A/400 V |
| | | CEE form (1x) |
| | | 3p + N + PE |
| | | 32 A/400 V |
| | | CEE form (1x) |
| | 3p + N + PE | |
| | 63 A/400 V | |
| | Dimensions (LxWxH) | 2097.1 x 950 x 1130.5 mm |
| | Weight net mass | 887 kg |
| | Weight wet mass | 986 kg |

Notes

- 1) Reference conditions for engine performance to ISO 3046-1.
- 2) See derating diagram or consult the factory for other conditions.
- 3) At reference conditions unless otherwise stated.
- 4) Rating definition (ISO 8528-1):
 LTP: Limited Time Power is the maximum electrical power which a generating set is capable of delivering (at variable load), in the event of a utility power failure (for up to 500 hours per year of which a maximum of 300 hours is continuous running). No overload is permitted on these ratings. The alternator is peak continuous rated (as defined in ISO 8528-3) at 25°C.
 PRP: Prime Power is the maximum power available during a variable power sequence, which may be run for an unlimited number of hours per year, between stated maintenance intervals and under the stated ambient conditions. A 10% overload is permitted for 1 hour in 12 hours. The permissible average power output during a 24h period shall not exceed the stated load factor of 100%.
- 5) Specific mass fuel used: 0.86 kg/l.

Derating

| Height (m) | Temperature (°C) | | | | | | | | | | |
|---------------|---------------------|-----|-----|-----|-----|-----|-----|----|----|----|----|
| | 0 | 5 | 10 | 15 | 20 | 25 | 30 | 35 | 40 | 45 | 50 |
| 0 | 100 | 100 | 100 | 100 | 100 | 100 | 100 | 95 | 95 | 90 | 90 |
| 500 | 100 | 100 | 100 | 95 | 95 | 95 | 90 | 90 | 85 | 85 | 85 |
| 1000 | 95 | 90 | 90 | 90 | 90 | 85 | 85 | 85 | 80 | 80 | 75 |
| 1500 | 85 | 85 | 85 | 85 | 80 | 80 | 80 | 75 | 75 | 75 | 70 |
| 2000 | 80 | 80 | 80 | 75 | 75 | 75 | 75 | 70 | 70 | 70 | 65 |
| 2500 | 75 | 75 | 75 | 70 | 70 | 70 | 65 | 65 | 65 | 65 | 60 |
| 3000 | 70 | 70 | 65 | 65 | 65 | 65 | 60 | 60 | 60 | 60 | 55 |
| 3500 | 65 | 65 | 60 | 60 | 60 | 60 | 60 | 55 | 55 | 55 | 50 |

Technical specifications for QAS 40 units

Readings on gauges

| <i>Gauge</i> | <i>Reading</i> | <i>Unit</i> |
|-----------------|-------------------|-------------|
| Ammeter L3 (P3) | Below max. rating | A |
| Voltmeter (P4) | Below max. rating | V |

Settings of switches

| <i>Switch</i> | <i>Function</i> | <i>Activates at</i> |
|----------------------------|-----------------|---------------------|
| Engine oil pressure | shut down | 0.5 bar |
| Engine coolant temperature | shut down | 105°C |

Specifications of the engine/alternator/unit

| | | 50 Hz |
|----------------------------------|---|----------------|
| <i>Reference conditions 1)</i> | Rated frequency | 50 Hz |
| | Rated speed | 1500 rpm |
| | Generator service duty | PRP |
| | Absolute air inlet pressure | 100 kPa |
| | Relative air humidity | 30% |
| | Air inlet temperature | 25°C |
| <i>Limitations 2)</i> | Maximum ambient temperature | 50°C |
| | Altitude capability | 4000 m |
| | Maximum relative air humidity | 85% |
| | Minimum starting temperature unaided | -18°C |
| | Minimum starting temperature aided (optional) | -25°C |
| <i>Performance data 2) 3) 5)</i> | Rated active power (PRP) 3ph | 32.9 kW |
| | Rated active power (PRP) 1ph | NA |
| | Rated power factor (lagging) 3ph | 0.8 cos ϕ |
| | Rated power factor (lagging) 1ph | NA |

| | |
|--|------------------|
| Rated PRP power 3ph | 41.1 kVA |
| Rated PRP power 1ph | NA |
| Rated voltage 3ph line to line | 400 V |
| Rated voltage 3ph line to line lower voltage | NA |
| Rated voltage 1ph | NA |
| Rated current 3ph | 59.3 A |
| Rated current 3ph lower voltage | NA |
| Rated current 1ph | NA |
| Performance class (acc.ISO 8528-5:1993) | G2 |
| Single step load acceptance (0-PRP) | 32.9 kW |
| | 100% |
| Frequency droop | < 5% |
| | isochronous |
| Fuel consumption at no load (0%) | 1.54 kg/h |
| Fuel consumption at 50% load | 4.16 kg/h |
| Fuel consumption at 75% load | 5.72 kg/h |
| Fuel consumption at full load (100%) | 7.53 kg/h |
| Specific fuel consumption (at full load, 100%) | 0.230 kg/kWh |
| Fuel autonomy at full load with standard tank | 10.5 h |
| Fuel autonomy at full load with extended fuel tank (optional) | 29.4 h |
| Max. oil consumption at full load | 37.7 g/h |
| Maximum sound power level (LWA) measured according to 2000/14/EC OND | 89 dB(A) |
| Capacity of fuel tank | 92 l |
| Capacity of optional skid,fuel tank (optional) | 257 l |
| Single step load capability (0-PRP) | 32.9 kW |
| | 100% |
| Mode of operation | PRP |
| Site | land use |
| Operation | single |
| Start-up and control mode | manual/automatic |
| Start-up time | unspecified |
| Mobility/ Config. acc. to ISO 8528-1:1993 | transportable/D |

Application data

| | | |
|----------------------|-----------------------------------|------------------|
| | (optional) | mobile/E |
| | Mounting | fully resilient |
| | Climatic exposure | open air |
| | Degree of protection | IP 54 |
| | Status of neutral (TT or TN) | earthed |
| | Status of neutral (IT) (optional) | insulated |
| <i>Alternator 4)</i> | Standard | IEC34-1 |
| | Make | ISO 8528-3 |
| | Model | STAMFORD |
| | Rated output, class H temp. rise | BC1184-J1 |
| | rating type acc. ISO 8528-3 | 42.5 kVA |
| | Degree of protection | BR |
| | Insulation stator class | IP 23 |
| | Insulation rotor class | H |
| | Number of wires | H |
| | | 12 |
| <i>Engine 4)</i> | Standard | ISO 3046 |
| | Type KUBOTA | ISO 8528-2 |
| | Rated net output | V3800DI-T |
| | rating type acc. ISO 3046-7 | 38.0 kW |
| | production tolerance | ICXN |
| | Coolant | ± 5% |
| | Combustion system | coolant |
| | Aspiration | direct injection |
| | Number of cylinders | turbo charged |
| | Swept volume | 4 |
| | Speed governing | 3.8 l |
| | Capacity of oil sump | electronic |
| | Capacity of cooling system | 13 l |
| | Electrical system | 7.5 l |
| | Emission compliance | 12 Vdc |
| | | EU STAGE II |

Power circuit

| | |
|--|---|
| Circuit-breaker, 3ph. | |
| Number of poles | 4 |
| Thermal release I _t (thermal release is higher at 25°C) | 63 A |
| Magnetic release I _m | 3..5xI _n |
| Circuit-breaker, 3ph., lower voltage | |
| Number of poles | NA |
| Thermal release I _t | NA |
| Magnetic release I _m | NA |
| Fault current protection | |
| Residual current release I _{Dn} | 0.030-30 A |
| Insulation resistance (optional) | 10-100 kOhm |
| Outlet sockets | domestic (1x) (optional) 2p + PE 16 A/230 V |
| | CEE form (1x) 3p + N + PE 16 A/400 V |
| | CEE form (1x) 3p + N + PE 32 A/400 V |
| | CEE form (1x) 3p + N + PE 63 A/400 V |
| Unit | |
| Dimensions (LxWxH) | 2097.1 x 950 x 1130.5 mm |
| Weight net mass | 945 kg |
| Weight wet mass | 1048 kg |

Notes

- 1) Reference conditions for engine performance to ISO 3046-1.
- 2) See derating diagram or consult the factory for other conditions.
- 3) At reference conditions unless otherwise stated.
- 4) Rating definition (ISO 8528-1):
 LTP: Limited Time Power is the maximum electrical power which a generating set is capable of delivering (at variable load), in the event of a utility power failure (for up to 500 hours per year of which a maximum of 300 hours is continuous running). No overload is permitted on these ratings. The alternator is peak continuous rated (as defined in ISO 8528-3) at 25°C.
 PRP: Prime Power is the maximum power available during a variable power sequence, which may be run for an unlimited number of hours per year, between stated maintenance intervals and under the stated ambient conditions. A 10% overload is permitted for 1 hour in 12 hours. The permissible average power output during a 24h period shall not exceed the stated load factor of 100%.
- 5) Specific mass fuel used: 0.86 kg/l.

Derating

| Height (m) | Temperature (°C) | | | | | | | | | | |
|---------------|---------------------|-----|-----|-----|-----|-----|----|----|----|----|----|
| | 0 | 5 | 10 | 15 | 20 | 25 | 30 | 35 | 40 | 45 | 50 |
| 0 | 100 | 100 | 100 | 100 | 100 | 100 | 95 | 95 | 90 | 85 | 85 |
| 500 | 100 | 100 | 100 | 100 | 100 | 95 | 90 | 90 | 85 | 80 | 80 |
| 1000 | 100 | 100 | 100 | 100 | 95 | 90 | 85 | 85 | 80 | 80 | 75 |
| 1500 | 100 | 100 | 95 | 95 | 90 | 85 | 85 | 80 | 75 | 75 | 70 |
| 2000 | 95 | 95 | 90 | 90 | 85 | 80 | 80 | 75 | 75 | 70 | 65 |
| 2500 | 90 | 90 | 85 | 85 | 80 | 75 | 75 | 70 | 70 | 65 | 65 |
| 3000 | 90 | 85 | 85 | 80 | 75 | 75 | 70 | 70 | 65 | 65 | 60 |
| 3500 | 85 | 80 | 80 | 75 | 75 | 70 | 65 | 65 | 60 | 60 | 55 |

Conversion list of SI units into British units

| | | |
|-----------------------|---|----------------------------|
| 1 bar | = | 14.504 psi |
| 1 g | = | 0.035 oz |
| 1 kg | = | 2.205 lb |
| 1 km/h | = | 0.621 mile/h |
| 1 kW | = | 1.341 hp (UK and US) |
| 1 l | = | 0.264 US gal |
| 1 l | = | 0.220 lmp gal (UK) |
| 1 l | = | 0.035 cu.ft |
| 1 m | = | 3.281 ft |
| 1 mm | = | 0.039 in |
| 1 m ³ /min | = | 35.315 cfm |
| 1 mbar | = | 0.401 in wc |
| 1 N | = | 0.225 lbf |
| 1 Nm | = | 0.738 lbf.ft |
| $t_{°F}$ | = | $32 + (1.8 \times t_{°C})$ |
| $t_{°C}$ | = | $(t_{°F} - 32)/1.8$ |

A temperature difference of 1°C = a temperature difference of 1.8°F.

Dataplate

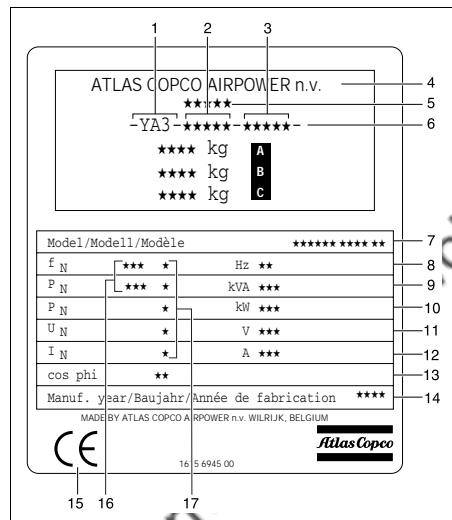

- A Maximum permitted total weight of the vehicle
- B Maximum permitted front axle load
- C Maximum permitted rear axle load
- 1 Company code
- 2 Product code
- 3 Unit serial number
- 4 Name of manufacturer
- 5 EEC or national type approved number
- 6 Vehicle identification number
- 7 Model number
- 8 Frequency
- 9 Apparant power - PRP
- 10 Active power - PRP
- 11 Nominal rated voltage
- 12 Nominal rated current
- 13 Power factor
- 14 Manufacturing year
- 15 EEC mark in accordance with Machine Directive 89/392E
- 16 Mode of operation
- 17 Winding connections

Machine Verhuur Oosterwolde

Circuit diagrams

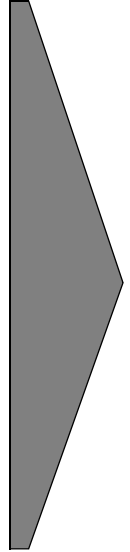

9822 0992 70/01

Applicable for QAS 30-40 Kd - Power circuit

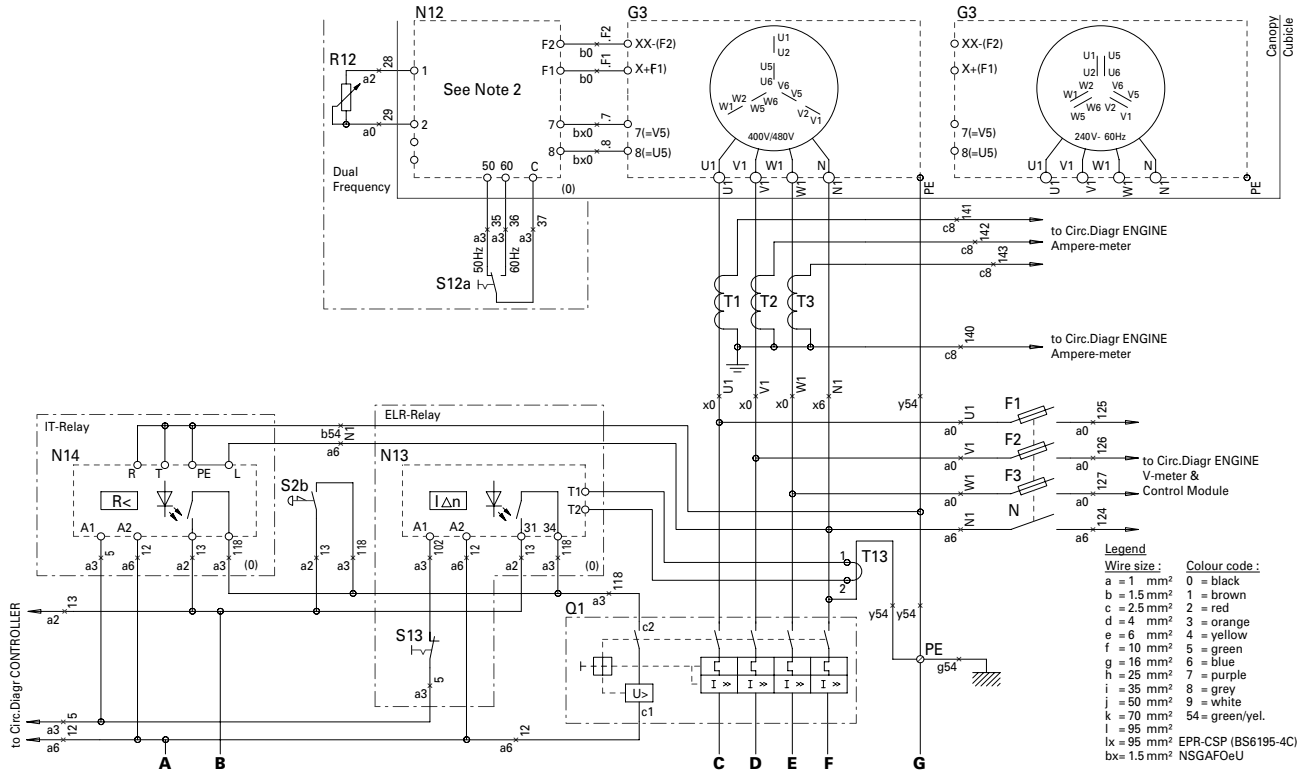

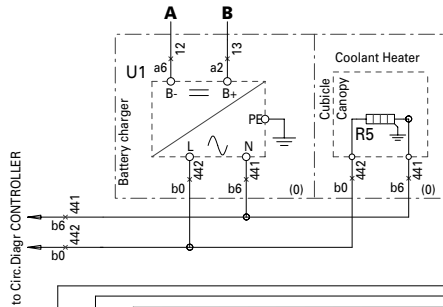

Notes

- Note 1: The PE-N connection has to be made at the alternator-side of main Circuit Breaker Q1.
- Note 2: Link N12.1 to N12.2 on gen-sets without Dual Frequency (= no potentiometer R12).
- Note 3: With "TB EDf", do NOT connect (N) to (PE) at Q1. T13 is to be mounted on the (PE)-conductor, instead of on the PE-N connection in the cubicle.

| | QAS | T1 | Q1 | Wire Size x | Wire Size y |
|-----------|-----|-------|-----|---------------------|---------------------|
| 400V/480V | 14 | 30/5A | 20A | 2.5 mm ² | 2.5 mm ² |
| | 20 | 30/5A | 32A | 6 mm ² | 6 mm ² |
| | 30 | 60/5A | 50A | 10 mm ² | 10 mm ² |
| | 40 | 60/5A | 63A | 16 mm ² | 16 mm ² |

| | QAS | T1 | Q1 | Wire Size x | Wire Size y |
|-----------|-----|--------|------|--------------------|-------------------|
| 240V-60Hz | 14 | 60/5A | 40A | 10 mm ² | 10mm ² |
| | 20 | 60/5A | 63A | 16 mm ² | 16mm ² |
| | 30 | 100/5A | 100A | 35 mm ² | 16mm ² |
| | 40 | 150/5A | 125A | 50 mm ² | 25mm ² |

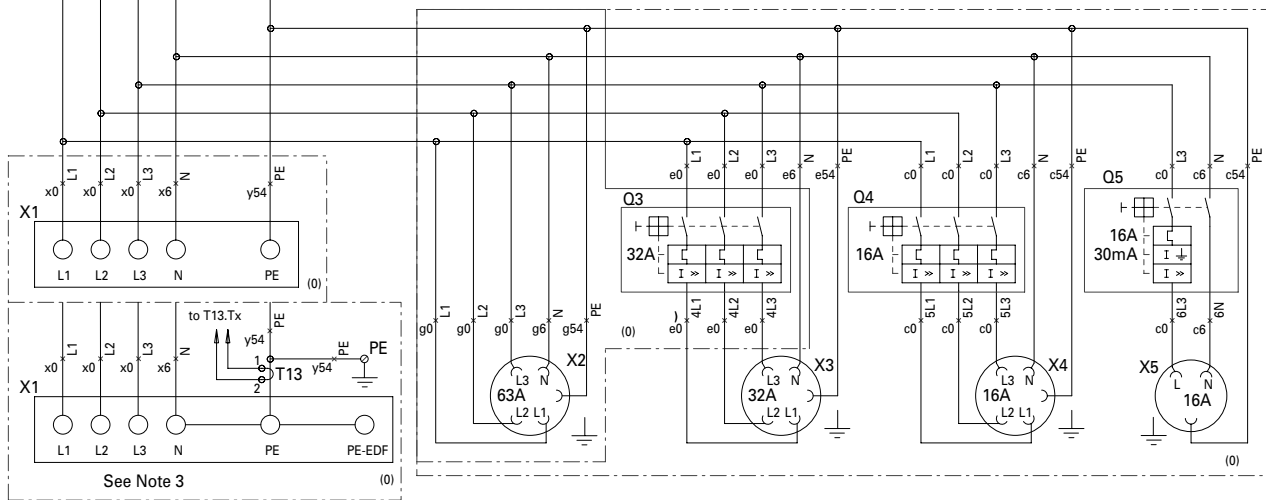

| | |
|-------|---|
| F1-F3 | Fuses 4 A |
| G3 | Alternator |
| N12 | Automatic voltage regulator |
| N13 | Earth leakage relay (O) |
| N14 | IT-relay (O) |
| Q1 | Circuit breaker (O) |
| Q3 | Circuit breaker 32 A (O) |
| Q4 | Circuit breaker 16 A (O) |
| Q5 | Circuit breaker 16 A/30 mA (O) |
| R5 | Coolant heater (O) |
| R12 | Voltage adjustment 1 k (O) |
| S2b | Emergency stop (S2a: see Controller circuit) |
| S12 | 50/60 Hz switch (O) |
| S13 | E.L.R. Disable switch (O) |
| T1-T3 | Current transformers |
| T13 | Torus earth leakage (O) |
| U1 | Battery charger (O) |
| X1 | Terminal board |
| X2 | Outlet socket 63 A (O) |
| X3 | Outlet socket 32 A (O) |
| X4 | Outlet socket 16 A (O) |
| X5 | Outlet socket 16 A (O) |
| (O) | Optional equipment |

Machine Verhuur Oosterwolde

Machine Verhuur Oosterwolde

| | |
|-----|--|
| B7 | Fuel level sensor |
| B11 | Speed sensor |
| E1 | Preheat resistor |
| G1 | Battery 12 Vdc |
| G2 | Charging alternator |
| K0 | Starter solenoid |
| K1 | Preheat relay |
| M1 | Starter motor |
| M6 | Fuel feed pump |
| N11 | Engine controller unit |
| S1 | Battery switch (O) |
| S8 | High coolant temperature switch |
| S9 | Low oil pressure switch |
| S10 | Coolant temperature sensor |
| X10 | Connector wire harness (see Controller circuit) |
| Y1 | Fuel solenoid |
| O | Optional equipment |

Machine Verhuur Oosterwolde

9822 0992 78/01

Applicable for QAS 30-40 Kd - Controller circuit Qc1002™

- A1 Generator control unit
(set A1 in unit-type 1)
- F10 Fuse 10 A DC
- H0 Panel light
- K4 W/L-invertor relay
- K5 Starter relay
- P1-P3 Amperemeter
- P4 Voltmeter
- S2a Emergency stop
(S2b: see Power circuit)
- S4 Voltmeter change-over switch
(S12a: see Power circuit)
- S12b On/Off/Remote switch
- X10 Connector wire harness
- X25 Customer's terminal strip
(O) Optional equipment

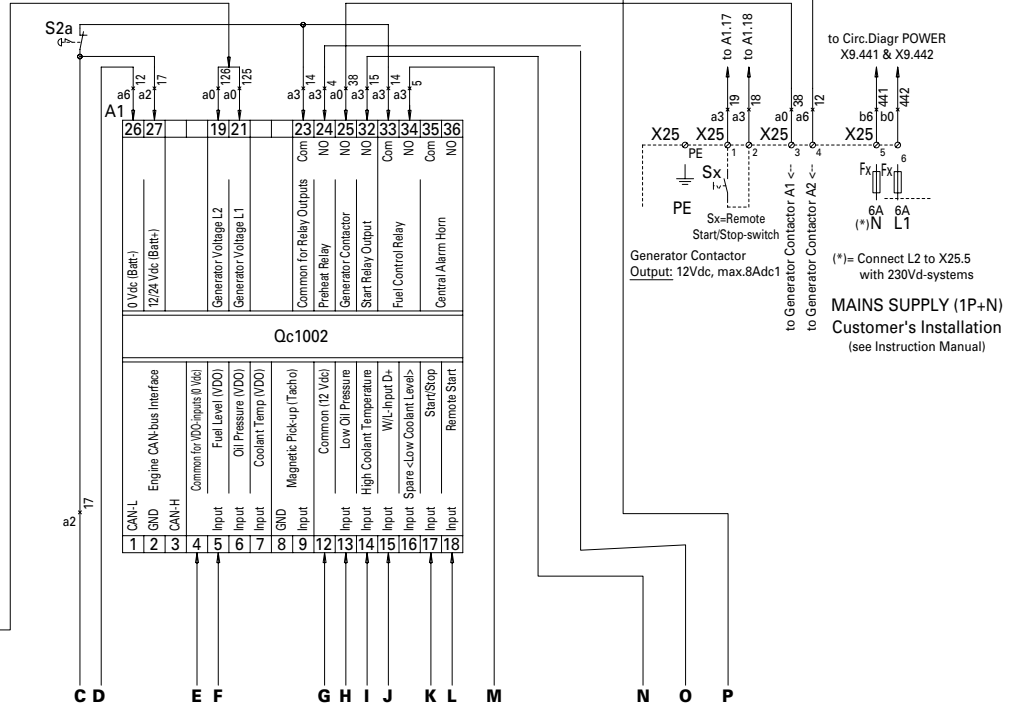

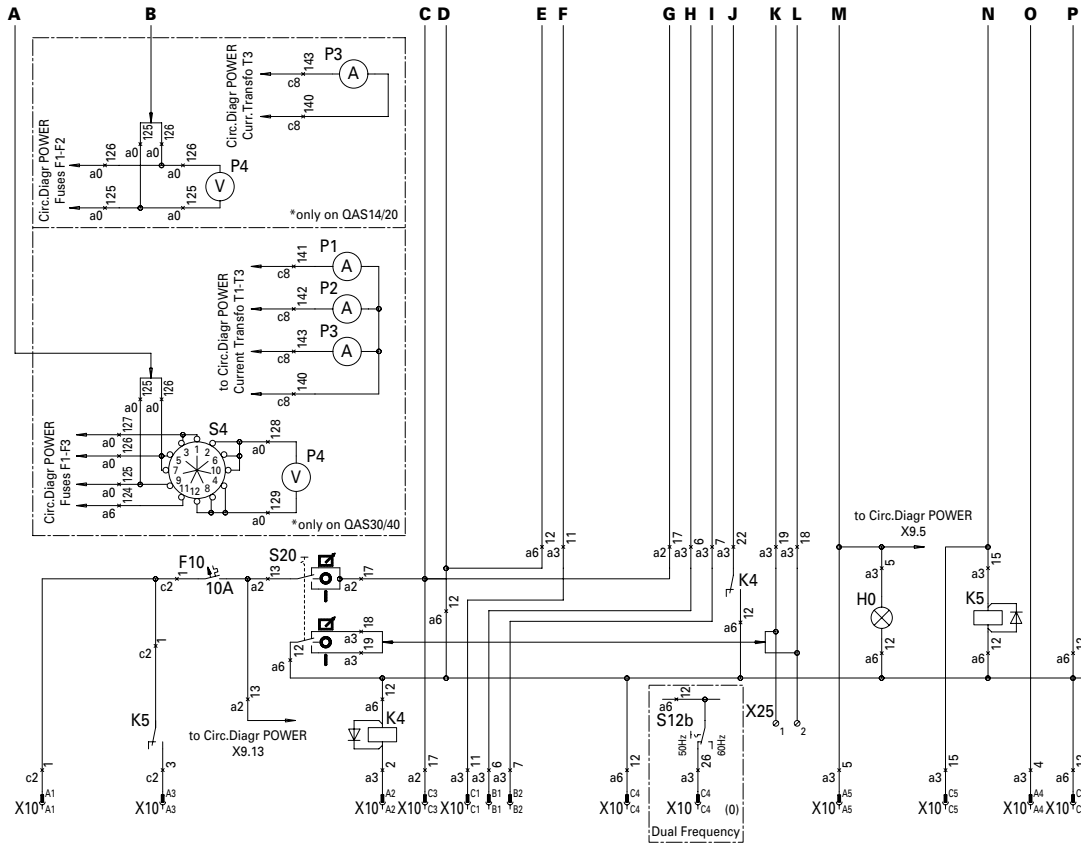

- Legend**
- Wire size :** **Colour code :**
- a = 1 mm² 0 = black
 - b = 1.5 mm² 1 = brown
 - c = 2.5 mm² 2 = red
 - d = 4 mm² 3 = orange
 - e = 6 mm² 4 = yellow
 - f = 10 mm² 5 = green
 - g = 16 mm² 6 = blue
 - h = 25 mm² 7 = purple
 - i = 35 mm² 8 = grey
 - j = 50 mm² 9 = white
 - k = 70 mm² 54 = green/yellow
 - l = 95 mm²
 - lx = 95 mm² EPR-CSP (BS6195-4C)
 - bx = 1.5 mm² NSGAFOeU

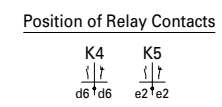

- A1 Generator control unit
(set A1 in unit-type 1)
- F10 Fuse 10 A DC
- K4 W/L-invertor relay
- K5 Starter relay
- S2a Emergency stop
(S2b: see Power circuit)
- S12b 50/60 Hz switch (O)
(S12a: see Power circuit)
- S20 On/Off switch
(see Engine Circuit)
- X10 Connector wire harness
- X25 Customer's terminal strip
(O)
- Optional equipment

Legend

| Wire size : | Colour code : |
|---|-------------------|
| a = 1 mm ² | 0 = black |
| b = 1.5 mm ² | 1 = brown |
| c = 2.5 mm ² | 2 = red |
| d = 4 mm ² | 3 = orange |
| e = 6 mm ² | 4 = yellow |
| f = 10 mm ² | 5 = green |
| g = 16 mm ² | 6 = blue |
| h = 25 mm ² | 7 = purple |
| i = 35 mm ² | 8 = grey |
| j = 50 mm ² | 9 = white |
| k = 70 mm ² | 54 = green/yellow |
| l = 95 mm ² | |
| lx = 95 mm ² EPR-CSP (BS6195-4C) | |
| bx = 1.5 mm ² NSGAFOeU | |

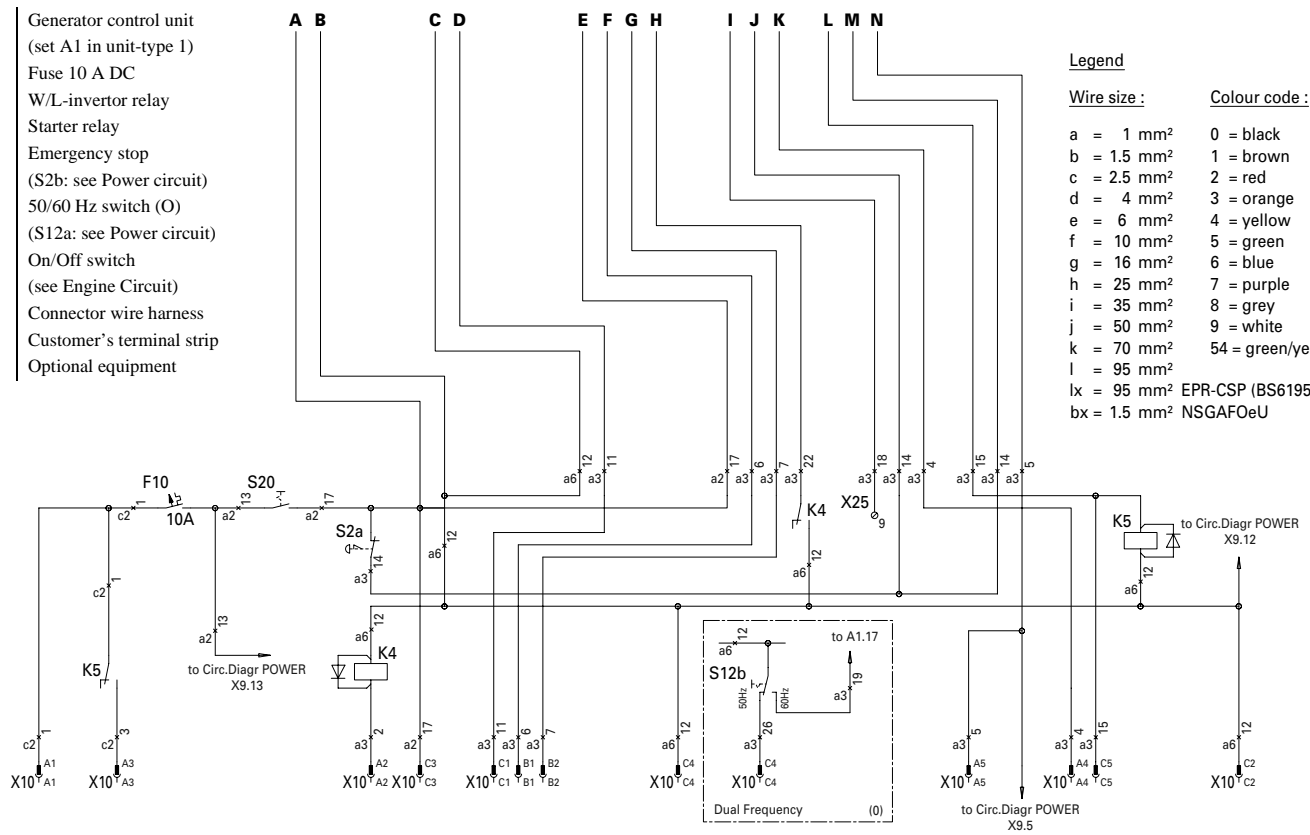

Machine Verhuur Oosterwolde

Machine Verhuur Oosterwolde



Machine Verhuur Oosterwolde

www.atlascopco.com

Printed in Belgium 04/2008 - 2954 3400 01