

XAS 67 Dd
XATS 67 Dd
XAS 77 Dd
XAS 97 Dd

Machine Verhuur Oosterwolde

Instruction Manual for Portable Compressors
English

Machine Verhuur Oosterwolde

**Instruction Manual
for Portable Compressors**

**XAS 67 Dd
XATS 67 Dd
XAS 77 Dd
XAS 97 Dd**

Machine Verhuur Oosterwolde

Machine Verhuur Oosterwolde

Warranty and Liability Limitation

Use only authorized parts.

Any damage or malfunction caused by the use of unauthorized parts is not covered by Warranty or Product Liability.

The manufacturer does not accept any liability for any damage arising for modifications, additions or conversions made without the manufacturer's approval in writing.

Copyright 2005, Atlas Copco Airpower n.v., Antwerp, Belgium.

Any unauthorized use or copying of the contents or any part thereof is prohibited. This applies in particular to trademarks, model denominations, part numbers and drawings.

Follow the instructions in this booklet and we guarantee you years of troublefree operation. Please read the following instructions carefully before starting to use your machine.

Always keep the manual available near the machine.

In all correspondence always mention the compressor type and serial number, shown on the data plate.

The company reserves the right to make changes without prior notice.

CALIFORNIA

Proposition 65 Warning

Diesel engine exhaust and some of its constituents are known to the State of California to cause cancer, birth defects, and other reproductive harm.

	CONTENTS	PAGE
1	Safety precautions for portable compressors (with generator)	7
1.1	Introduction	7
1.2	General safety precautions	7
1.3	Safety during transport and installation	8
1.4	Safety during use and operation	9
1.5	Safety during maintenance and repair	10
1.6	Tool applications safety	10
1.7	Specific safety precautions	11
2	Leading particulars	12
2.1	Description of safety pictograms used in this manual	12
2.2	General description	12
2.3	Markings and information labels.....	14
2.4	Main Parts	15
2.5	Air flow	17
2.6	Oil system.....	17
2.7	Continuous regulating system	17
2.8	Electrical system	18
2.8.1	Circuit diagram (standard)	18
2.8.2	Circuit diagram XAS 67 DdG, XAS 97 DdG (Generator DdG 110V without automatic control system)	20
2.8.3	Circuit diagram XAS 67 DdG, XAS 97 DdG (Generator DdG 110V with automatic control system)	22
2.8.4	Circuit diagram XAS 67 DdG, XAS 97 DdG (Generator DdG IT 230/400V, 6 kVA without automatic control system)	24
2.8.5	Circuit diagram XAS 67 DdG, XAS 97 DdG (Generator DdG IT 230/400V, 6 kVA with automatic control system)	26
2.8.6	Circuit diagram XAS 67 DdG, XAS 97 DdG (Generator DdG IT 230V, 6 kVA).....	28
2.8.7	Circuit diagram XAS 67 DdG, XAS 97 DdG (Generator DdG IT 230/400V, 12.5 kVA without automatic control system)	30

CONTENTS	PAGE	CONTENTS	PAGE
2.8.8	32	4.8	51
Circuit diagram XAS 67 DdG, XAS 97 DdG (Generator DdG IT 230/400V, 12.5 kVA with automatic control system).....		4.9	51
2.8.9	34	4.9.1	51
Circuit diagram XAS 67 DdG, XAS 97 DdG (Generator DdG IT 230V, 12.5 kVA).....		4.9.2	52
2.8.10	36	4.9.3	52
Circuit diagram cold start (all types)		4.9.4	52
2.8.11	37	4.10	52
Circuit diagram refinery equipment (all types).....		4.11	52
3	38	4.12	52
Operating instructions		4.13	52
3.1	38	4.14	52
Parking, towing and lifting instructions.....		4.15	52
3.1.1	38	5	53
Parking instructions		5.1	53
3.1.2	39	5.2	54
Towing instructions		5.2.1	54
3.1.3	39	5.2.2	54
Height adjustment (with adjustable towbar).....		5.2.3	54
3.1.4	40	5.2.4	54
Lifting instructions.....		5.3	54
3.1.5	40	5.4	54
Spillage-Free Instruction.....		5.5	55
3.1.6	40	5.6	55
Anti-Frost Device (option).....		5.6.1	55
3.2	40	5.6.2	56
Starting/Stopping		5.6.3	56
3.2.1	40	5.7	56
Before starting.....		6	57
3.2.2	41	6.1	57
Starting procedure (with cold start; option).....		7	59
3.2.3	42	Available options	
Starting procedure (without cold start)		8	60
3.2.4	43	8.1	60
During operation		8.1.1	60
3.2.5	43	8.1.2	60
Stopping procedure		8.2	60
3.2.6	43	8.3	61
Fault situations and protective devices:.....		8.4	68
3.3	44	9	69
Function of generator (option).....		Data plate	
3.3.1	44		
Function of generator DdG 110V without automatic control system - Functional description.....			
3.3.2	45		
Function of generator DdG 110V with automatic control system (option) - Functional description.....			
3.3.3	46		
Function of generator DdG 230/400V and 230V - 3ph without automatic control system - Functional description.....			
3.3.4	47		
Function of generator DdG 230/400V and 230V - 3ph with automatic control system (option) - Functional description			
4	48		
Maintenance			
4.1	48		
Use of service paks			
4.2	48		
Preventive maintenance schedule for the compressor			
4.3	49		
Lubrication oils			
4.4	49		
Oil level check			
4.4.1	49		
Check engine oil level.....			
4.4.2	50		
Check compressor oil level.....			
4.5	50		
Oil and oil filter change			
4.5.1	50		
Engine oil and oil filter change.....			
4.5.2	50		
Compressor oil and oil filter change.....			
4.6	51		
Cleaning coolers			
4.7	51		
Cleaning fuel tank.....			

1. SAFETY PRECAUTIONS FOR PORTABLE COMPRESSORS (WITH GENERATOR)

To be read attentively and acted accordingly before towing, lifting, operating, performing maintenance or repairing the unit

1.1 INTRODUCTION

The policy of Atlas Copco is to provide the users of their equipment with safe, reliable and efficient products. Factors taken into account are among others:

- the intended and predictable future use of the products, and the environments in which they are expected to operate,
- applicable rules, codes and regulations,
- the expected useful product life, assuming proper service and maintenance,
- providing the manual with up-to-date information.

Before handling any product, take time to read the relevant instruction manual. Besides giving detailed operating instructions, it also gives specific information about safety, preventive maintenance, etc.

Keep the manual always at the unit location, easy accessible to the operating personnel.

See also the safety precautions of the engine and possible other equipment, which are separately sent along or are mentioned on the equipment or parts of the unit.

These safety precautions are general and some statements will therefore not always apply to a particular unit.

Only people that have the right skills should be allowed to operate, adjust, perform maintenance or repair on Atlas Copco equipment. It is the responsibility of management to appoint operators with the appropriate training and skill for each category of job.

Skill level 1: Operator

An operator is trained in all aspects of operating the unit with the push-buttons, and is trained to know the safety aspects.

Skill level 2: Mechanical technician

A mechanical technician is trained to operate the unit the same as the operator. In addition, the mechanical technician is also trained to perform maintenance and repair, as described in the instruction manual, and is allowed to change settings of the control and safety system. A mechanical technician does not work on live electrical components.

Skill level 3: Electrical technician

An electrical technician is trained and has the same qualifications as both the operator and the mechanical technician. In addition, the electrical technician may carry out electrical repairs within the various enclosures of the unit. This includes work on live electrical components.

Skill level 4: Specialist from the manufacturer

This is a skilled specialist sent by the manufacturer or its agent to perform complex repairs or modifications to the equipment.

In general it is recommended that not more than two people operate the unit, more operators could lead to unsafe operating conditions. Take necessary steps to keep unauthorized persons away from the unit and eliminate all possible sources of danger at the unit.

When handling, operating, overhauling and/or performing maintenance or repair on Atlas Copco equipment, the mechanics are expected to use safe engineering practices and to observe all relevant local safety requirements and ordinances. The following list is a reminder of special safety directives and precautions mainly applicable to Atlas Copco equipment.

These safety precautions apply to machinery processing or consuming air. Processing of any other gas requires additional safety precautions typical to the application and are not included herein.

Neglecting the safety precautions may endanger people as well as environment and machinery:

- endanger people due to electrical, mechanical or chemical influences,
- endanger the environment due to leakage of oil, solvents or other substances,
- endanger the machinery due to function failures.

All responsibility for any damage or injury resulting from neglecting these precautions or by non-observance of ordinary caution and due care required in handling, operating, maintenance or repair, also if not expressly mentioned in this instruction manual, is disclaimed by Atlas Copco.

The manufacturer does not accept any liability for any damage arising from the use of non-original parts and for modifications, additions or conversions made without the manufacturer's approval in writing.

If any statement in this manual does not comply with local legislation, the stricter of the two shall be applied.

Statements in these safety precautions should not be interpreted as suggestions, recommendations or inducements that it should be used in violation of any applicable laws or regulations.

1.2 GENERAL SAFETY PRECAUTIONS

- 1 The owner is responsible for maintaining the unit in a safe operating condition. Unit parts and accessories must be replaced if missing or unsuitable for safe operation.
- 2 The supervisor, or the responsible person, shall at all times make sure that all instructions regarding machinery and equipment operation and maintenance are strictly followed and that the machines with all accessories and safety devices, as well as the consuming devices, are in good repair, free of abnormal wear or abuse, and are not tampered with.
- 3 Whenever there is an indication or any suspicion that an internal part of a machine is overheated, the machine shall be stopped but no inspection covers shall be opened before sufficient cooling time has elapsed; this to avoid the risk of spontaneous ignition of oil vapour when air is admitted.
- 4 Normal ratings (pressures, temperatures, speeds, etc.) shall be durably marked.
- 5 Operate the unit only for the intended purpose and within its rated limits (pressure, temperature, speeds, etc.).
- 6 The machinery and equipment shall be kept clean, i.e. as free as possible from oil, dust or other deposits.
- 7 To prevent an increase in working temperature, inspect and clean heat transfer surfaces (cooler fins, intercoolers, water jackets, etc.) regularly. See the maintenance schedule.
- 8 All regulating and safety devices shall be maintained with due care to ensure that they function properly. They may not be put out of action.
- 9 Care shall be taken to avoid damage to safety valves and other pressure-relief devices, especially to avoid plugging by paint, oil coke or dirt accumulation, which could interfere with the functioning of the device.
- 10 Pressure and temperature gauges shall be checked regularly with regard to their accuracy. They shall be replaced whenever outside acceptable tolerances.
- 11 Safety devices shall be tested as described in the maintenance schedule of the instruction manual to determine that they are in good operating condition.
- 12 Mind the markings and information labels on the unit.
- 13 In the event the safety labels are damaged or destroyed, they must be replaced to ensure operator safety.
- 14 Keep the work area neat. Lack of order will increase the risk of accidents.
- 15 When working on the unit, wear safety clothing. Depending on the kind of activities these are: safety glasses, ear protection, safety helmet (including visor), safety gloves, protective clothing, safety shoes. Do not wear the hair long and loose (protect long hair with a hairnet), or wear loose clothing or jewelry.

- 16 Take precautions against fire. Handle fuel, oil and anti-freeze with care because they are inflammable substances. Do not smoke or approach with naked flame when handling such substances. Keep a fire-extinguisher in the vicinity.
- 17a **Portable compressors with generator (with earthing pin):**
Earth the generator as well as the load properly.
- 17b **Portable compressors with generator IT:**
Note: This generator is built to supply a sheer alternating current IT network.
Earth the load properly.
- 11 Locate the unit away from walls. Take all precautions to ensure that hot air exhausted from the engine and driven machine cooling systems cannot be recirculated. If such hot air is taken in by the engine or driven machine cooling fan, this may cause overheating of the unit; if taken in for combustion, the engine power will be reduced.
- 12 The electrical connections shall correspond to local codes. The machines shall be earthed and protected against short circuits by fuses or circuit breakers.
- 13 Never connect the generator outlets to an installation which is also connected to a public mains.
- 14 Before connecting a load, switch off the corresponding circuit breaker, and check whether frequency, voltage, current and power factor comply with the ratings of the generator.

1.3 SAFETY DURING TRANSPORT AND INSTALLATION

To lift a unit, all loose or pivoting parts, e.g. doors and towbar, shall first be securely fastened.

Do not attach cables, chains or ropes directly to the lifting eye; apply a crane hook or lifting shackle meeting local safety regulations. Never allow sharp bends in lifting cables, chains or ropes.

Helicopter lifting is not allowed.

It is strictly forbidden to dwell or stay in the risk zone under a lifted load. Never lift the unit over people or residential areas. Lifting acceleration and retardation shall be kept within safe limits.

- 1 Before towing the unit:
 - ascertain that the pressure vessel(s) is (are) depressurized,
 - check the towbar, the brake system and the towing eye. Also check the coupling of the towing vehicle,
 - check the towing and brake capability of the towing vehicle,
 - check that the towbar, jockey wheel or stand leg is safely locked in the raised position,
 - ascertain that the towing eye can swivel freely on the hook,
 - check that the wheels are secure and that the tyres are in good condition and inflated correctly,
 - connect the signalisation cable, check all lights and connect the pneumatic brake couplers,
 - attach the safety break-away cable or safety chain to the towing vehicle,
 - remove wheel chocks, if applied, and disengage the parking brake.
- 2 To tow a unit use a towing vehicle of ample capacity. Refer to the documentation of the towing vehicle.
- 3 If the unit is to be backed up by the towing vehicle, disengage the overrun brake mechanism (if it is not an automatic mechanism).
- 4 Never exceed the maximum towing speed of the unit (mind the local regulations).
- 5 Place the unit on level ground and apply the parking brake before disconnecting the unit from the towing vehicle. Unclip the safety break-away cable or safety chain. If the unit has no parking brake or jockey wheel, immobilize the unit by placing chocks in front of and/or behind the wheels. When the towbar can be positioned vertically, the locking device must be applied and kept in good order.
- 6 To lift heavy parts, a hoist of ample capacity, tested and approved according to local safety regulations, shall be used.
- 7 Lifting hooks, eyes, shackles, etc., shall never be bent and shall only have stress in line with their design load axis. The capacity of a lifting device diminishes when the lifting force is applied at an angle to its load axis.
- 8 For maximum safety and efficiency of the lifting apparatus all lifting members shall be applied as near to perpendicular as possible. If required, a lifting beam shall be applied between hoist and load.
- 9 Never leave a load hanging on a hoist.
- 10 A hoist has to be installed in such a way that the object will be lifted perpendicular. If that is not possible, the necessary precautions must be taken to prevent load-swinging, e.g. by using two hoists, each at approximately the same angle not exceeding 30° from the vertical.

1.4 SAFETY DURING USE AND OPERATION

- 1 When the unit has to operate in a fire-hazardous environment, each engine exhaust has to be provided with a spark arrester to trap incendiary sparks.
- 2 The exhaust contains carbon monoxide which is a lethal gas. When the unit is used in a confined space, conduct the engine exhaust to the outside atmosphere by a pipe of sufficient diameter; do this in such a way that no extra back pressure is created for the engine. If necessary, install an extractor. Observe any existing local regulations. Make sure that the unit has sufficient air intake for operation. If necessary, install extra air intake ducts.
- 3 When operating in a dust-laden atmosphere, place the unit so that dust is not carried towards it by the wind. Operation in clean surroundings considerably extends the intervals for cleaning the air intake filters and the cores of the coolers.
- 4 Close the compressor air outlet valve before connecting or disconnecting a hose. Ascertain that a hose is fully depressurized before disconnecting it. Before blowing compressed air through a hose or air line, ensure that the open end is held securely, so that it cannot whip and cause injury.
- 5 The air line end connected to the outlet valve must be safeguarded with a safety cable, attached next to the valve.
- 6 No external force may be exerted on the air outlet valves, e.g. by pulling on hoses or by installing auxiliary equipment directly to a valve, e.g. a water separator, a lubricator, etc. Do not step on the air outlet valves.
- 7 Never move a unit when external lines or hoses are connected to the outlet valves, to avoid damage to valves, manifold and hoses.
- 8 Do not use compressed air from any type of compressor, without taking extra measures, for breathing purposes as this may result in injury or death. For breathing air quality, the compressed air must be adequately purified according to local legislation and standards. Breathing air must always be supplied at stable, suitable pressure.
- 9 Distribution pipework and air hoses must be of correct diameter and suitable for the working pressure. Never use frayed, damaged or deteriorated hoses. Replace hoses and flexibles before the lifetime expires. Use only the correct type and size of hose end fittings and connections.
- 10 If the compressor is to be used for sand-blasting or will be connected to a common compressed-air system, fit an appropriate non-return valve (check valve) between compressor outlet and the connected sand-blasting or compressed-air system. Observe the right mounting position/direction.
- 11 Before removing the oil filler plug, ensure that the pressure is released by opening an air outlet valve.
- 12 Never remove a filler cap of the cooling water system of a hot engine. Wait until the engine has sufficiently cooled down.
- 13 Never refill fuel while the unit is running, unless otherwise stated in the Atlas Copco Instruction Book (AIB). Keep fuel away from hot parts such as air outlet pipes or the engine exhaust. Do not smoke when fuelling. When fuelling from an automatic pump, an earthing cable should be connected to the unit to discharge static electricity. Never spill nor leave oil, fuel, coolant or cleansing agent in or around the unit.
- 14 All doors shall be shut during operation so as not to disturb the cooling air flow inside the bodywork and/or render the silencing less effective. A door should be kept open for a short period only e.g. for inspection or adjustment.
- 15 Periodically carry out maintenance works according to the maintenance schedule.
- 16 Stationary housing guards are provided on all rotating or reciprocating parts not otherwise protected and which may be hazardous to personnel. Machinery shall never be put into operation, when such guards have been removed, before the guards are securely reinstalled.
- 17 Noise, even at reasonable levels, can cause irritation and disturbance which, over a long period of time, may cause severe injuries to the nervous system of human beings.
When the sound pressure level, at any point where personnel normally has to attend, is:
below 70 dB(A): no action needs to be taken,
above 70 dB(A): noise-protective devices should be provided for people continuously being present in the room,
below 85 dB(A): no action needs to be taken for occasional visitors staying a limited time only,
above 85 dB(A): room to be classified as a noise-hazardous area and an obvious warning shall be placed permanently at each entrance to alert people entering the room, for even relatively short times, about the need to wear ear protectors,
above 95 dB(A): the warning(s) at the entrance(s) shall be completed with the recommendation that also occasional visitors shall wear ear protectors,
above 105 dB(A): special ear protectors that are adequate for this noise level and the spectral composition of the noise shall be provided and a special warning to that effect shall be placed at each entrance.
- 18 Insulation or safety guards of parts the temperature of which can be in excess of 80 °C (175 °F) and which may be accidentally touched by personnel shall not be removed before the parts have cooled to room temperature.
- 19 Never operate the unit in surroundings where there is a possibility of taking in flammable or toxic fumes.
- 20 If the working process produces fumes, dust or vibration hazards, etc., take the necessary steps to eliminate the risk of personnel injury.
- 21 When using compressed air or inert gas to clean down equipment, do so with caution and use the appropriate protection, at least safety glasses, for the operator as well as for any bystander. Do not apply compressed air or inert gas to your skin or direct an air or gas stream at people. Never use it to clean dirt from your clothes.
- 22 When washing parts in or with a cleaning solvent, provide the required ventilation and use appropriate protection such as a breathing filter, safety glasses, rubber apron and gloves, etc.
- 23 Safety shoes should be compulsory in any workshop and if there is a risk, however small, of falling objects, wearing of a safety helmet should be included.
- 24 If there is a risk of inhaling hazardous gases, fumes or dust, the respiratory organs must be protected and depending on the nature of the hazard, so must the eyes and skin.
- 25 Remember that where there is visible dust, the finer, invisible particles will almost certainly be present too; but the fact that no dust can be seen is not a reliable indication that dangerous, invisible dust is not present in the air.
- 26 Never operate the unit at pressures or speeds below or in excess of its limits as indicated in the technical specifications.
- 27 Never operate the generator in excess of its limits as indicated in the technical specifications and avoid long no-load sequences.
- 28 Never operate the generator in a humid atmosphere. Excessive moisture causes worsening of the generator insulation.
- 29 Do not open electrical cabinets, cubicles or other equipment while voltage is supplied. If such cannot be avoided, e.g. for measurements, tests or adjustments, have the action carried out by a qualified electrician only, with appropriate tools, and ascertain that the required bodily protection against electrical hazards is applied.
- 30 Never touch the power terminals during operation of the machine.
- 31 Whenever an abnormal condition arises, e.g. excessive vibration, noise, odour, etc., switch the circuit breakers to OFF and stop the engine. Correct the faulty condition before restarting.
- 32 Check the electric cables regularly. Damaged cables and insufficient lightening of connections may cause electric shocks. Whenever damaged wires or dangerous conditions are observed, switch the circuit breakers to OFF and stop the engine. Replace the damaged wires or correct the dangerous condition before restarting. Make sure that all electric connections are securely tightened.

- 33 Avoid overloading the generator. The generator is provided with circuit breakers for overload protection. When a breaker has tripped, reduce the concerned load before restarting.
- 34 If the generator is used as stand-by for the mains supply, it must not be operated without control system which automatically disconnects the generator from the mains when the mains supply is restored.
- 35 Never remove the cover of the output terminals during operation. Before connecting or disconnecting wires, switch off the load and the circuit breakers, stop the machine and make sure that the machine cannot be started inadvertently or there is any residual voltage on the power circuit.
- 36 Running the generator at low load for long periods will reduce the lifetime of the engine.

1.5 SAFETY DURING MAINTENANCE AND REPAIR

Maintenance, overhaul and repair work shall only be carried out by adequately trained personnel; if required, under supervision of someone qualified for the job.

- 1 Use only the correct tools for maintenance and repair work, and only tools which are in good condition.
- 2 Parts shall only be replaced by genuine Atlas Copco replacement parts.
- 3 All maintenance work, other than routine attention, shall only be undertaken when the unit is stopped. Steps shall be taken to prevent inadvertent starting. In addition, a warning sign bearing a legend such as "work in progress; do not start" shall be attached to the starting equipment.
On engine-driven units the battery shall be disconnected and removed or the terminals covered by insulating caps.
On electrically driven units the main switch shall be locked in open position and the fuses shall be taken out. A warning sign bearing a legend such as "work in progress; do not supply voltage" shall be attached to the fuse box or main switch.
- 4 Before dismantling any pressurized component, the compressor or equipment shall be effectively isolated from all sources of pressure and the entire system shall be relieved of pressure. Do not rely on non-return valves (check valves) to isolate pressure systems. In addition, a warning sign bearing a legend such as "work in progress; do not open" shall be attached to each of the outlet valves.
- 5 Prior to stripping an engine or other machine or undertaking major overhaul on it, prevent all movable parts from rolling over or moving.
- 6 Make sure that no tools, loose parts or rags are left in or on the machine. Never leave rags or loose clothing near the engine air intake.
- 7 Never use flammable solvents for cleaning (fire risk).
- 8 Take safety precautions against toxic vapours of cleaning liquids.
- 9 Never use machine parts as a climbing aid.
- 10 Observe scrupulous cleanliness during maintenance and repair. Keep away dirt, cover the parts and exposed openings with a clean cloth, paper or tape.
- 11 Never weld on or perform any operation involving heat near the fuel or oil systems. Fuel and oil tanks must be completely purged, e.g. by steam-cleaning, before carrying out such operations. Never weld on, or in any way modify, pressure vessels. Disconnect the alternator cables during arc welding on the unit.
- 12 Support the towbar and the axle(s) securely if working underneath the unit or when removing a wheel. Do not rely on jacks.
- 13 Do not remove any of, or tamper with, the sound-damping material. Keep the material free of dirt and liquids such as fuel, oil and cleansing agents. If any sound-damping material is damaged, replace it to prevent the sound pressure level from increasing.
- 14 Use only lubricating oils and greases recommended or approved by Atlas Copco or the machine manufacturer. Ascertain that the selected lubricants comply with all applicable safety regulations, especially with regard to explosion or fire-risk and the possibility of decomposition or generation of hazardous gases. Never mix synthetic with mineral oil.
- 15 Protect the engine, alternator, air intake filter, electrical and regulating components, etc., to prevent moisture ingress, e.g. when steam-cleaning.

- 16 When performing any operation involving heat, flames or sparks on a machine, the surrounding components shall first be screened with non-flammable material.
- 17 Never use a light source with open flame for inspecting the interior of a machine.
- 18 When repair has been completed, the machine shall be barred over at least one revolution for reciprocating machines, several revolutions for rotary ones to ensure that there is no mechanical interference within the machine or driver. Check the direction of rotation of electric motors when starting up the machine initially and after any alteration to the electrical connection(s) or switch gear, to check that the oil pump and the fan function properly.
- 19 Maintenance and repair work should be recorded in an operator's logbook for all machinery. Frequency and nature of repairs can reveal unsafe conditions.
- 20 When hot parts have to be handled, e.g. shrink fitting, special heat-resistant gloves shall be used and, if required, other body protection shall be applied.
- 21 When using cartridge type breathing filter equipment, ascertain that the correct type of cartridge is used and that its useful service life is not surpassed.
- 22 Make sure that oil, solvents and other substances likely to pollute the environment are properly disposed of.
- 23 Before clearing the unit for use after maintenance or overhaul, check that operating pressures, temperatures and speeds are correct and that the control and shutdown devices function correctly. Submit the generator to a testrun, check that the AC power performance is correct.

1.6 TOOL APPLICATIONS SAFETY

Apply the proper tool for each job. With the knowledge of correct tool use and knowing the limitations of tools, along with some common sense, many accidents can be prevented.

Special service tools are available for specific jobs and should be used when recommended. The use of these tools will save time and prevent damage to parts.

1.7 SPECIFIC SAFETY PRECAUTIONS

Batteries

When servicing batteries, always wear protecting clothing and glasses.

- 1 The electrolyte in batteries is a sulphuric acid solution which is fatal if it hits your eyes, and which can cause burns if it contacts your skin. Therefore, be careful when handling batteries, e.g. when checking the charge condition.
- 2 Install a sign prohibiting fire, open flame and smoking at the post where batteries are being charged.
- 3 When batteries are being charged, an explosive gas mixture forms in the cells and might escape through the vent holes in the plugs. Thus an explosive atmosphere may form around the battery if ventilation is poor, and can remain in and around the battery for several hours after it has been charged. Therefore:
 - never smoke near batteries being, or having recently been, charged,
 - never break live circuits at battery terminals, because a spark usually occurs.
- 4 When connecting an auxiliary battery (AB) in parallel to the unit battery (CB) with booster cables: connect the + pole of AB to the + pole of CB, then connect the - pole of CB to the mass of the unit. Disconnect in the reverse order.

Pressure vessels

(according to directive 87/404/EEC annex II § 2)

Maintenance/installation requirements:

- 1 The vessel can be used as pressure vessel or as separator and is designed to hold compressed air for the following application:
 - pressure vessel for compressor,
 - medium AIR/OIL,and operates as detailed on the data plate of the vessel:
 - the maximum working pressure ps in bar,
 - the maximum working temperature Tmax in °C,
 - the minimum working temperature Tmin in °C,
 - the capacity of the vessel V in l.
- 2 The pressure vessel is only to be used for the applications as specified above and in accordance with the technical specifications. Safety reasons prohibit any other applications.
- 3 National legislation requirements with respect to re-inspection must be complied with.
- 4 No welding or heat treatment of any kind is permitted to those vessel walls which are exposed to pressure.
- 5 The vessel is provided and may only be used with the required safety equipment such as manometer, overpressure control devices, safety valve, etc.
- 6 Draining of condensate shall be performed regularly when vessel is in use.
- 7 Installation, design and connections should not be changed.
- 8 Bolts of cover and flanges may not be used for extra fixation.

Safety valves

All adjustments or repairs are to be done by an authorized representative of the valve supplier (see [maintenance schedule 4.2](#)).

2. LEADING PARTICULARS

2.1 DESCRIPTION OF SAFETY PICTOGRAMS USED IN THIS MANUAL



This symbol draws your attention to dangerous situations. The operation concerned may endanger persons and cause injuries.



This symbol is followed by supplementary information.

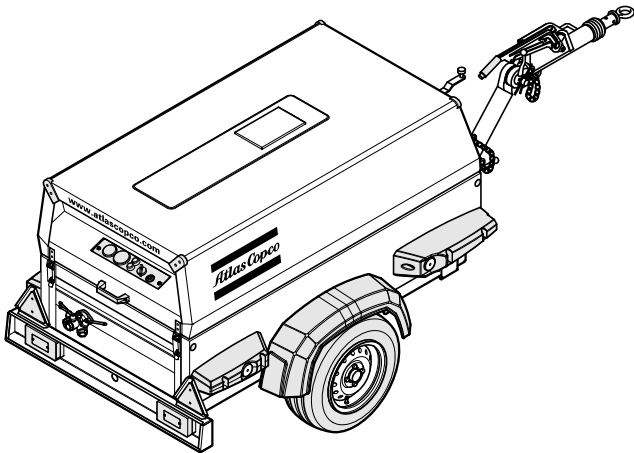

Fig. 2.1.a General view standard

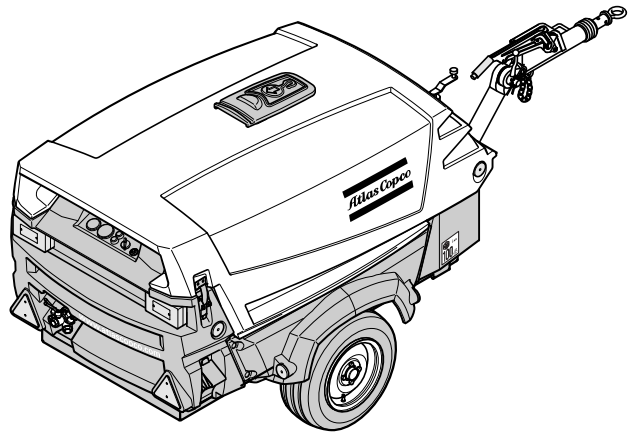

Fig. 2.1.b General view hardhat (option)

2.2 GENERAL DESCRIPTION

The compressors type XAS 67 Dd, XATS 67 Dd, XAS 77 Dd and XAS 97 Dd are silenced, single-stage, oil-injected screw compressors, built for a nominal effective working pressure, ranging from 7 bar up to 10.3 bar (see chapter 8, technical specifications).

– Engine

The compressor is driven by an oil-cooled diesel engine. The engine's power is transmitted to the compressor through a heavy-duty drive belt (XAS 67 Dd, XATS 67 Dd) or a heavy-duty coupling (XAS 77 Dd, XAS 97 Dd).

– Compressor

The compressor casing houses two screw-type rotors, mounted on ball and roller bearings. The male rotor, driven by the engine, drives the female rotor. The element delivers pulsation-free air.

Injected oil is used for sealing, cooling and lubricating purposes.

– Compressor oil system

The oil is boosted by air pressure. The system has no oil pump.

The oil is removed from the air, in the air/oil vessel at first by centrifugal force, secondly through the oil separator element.

The vessel is provided with an oil level indicator.

– Regulation

The compressor is provided with a continuous regulating system and a blow-down valve which is integrated in the unloader assembly. The valve is closed during operation by outlet pressure of the compressor element and opens by air receiver pressure when the compressor is stopped.

When the air consumption increases, the air receiver pressure will decrease and vice versa.

This receiver pressure variation is sensed by the regulating valve which, by means of control air to the unloader and engine speed regulator, matches the air output to the air consumption. The air receiver pressure is maintained between the pre-selected working pressure and the corresponding unloading pressure.

– Cooling system

Engine and compressor are provided with an oil cooler. The cooling air is generated by a fan, driven by the engine.

– Safety devices

A thermal shut-down switch protects the compressor against overheating. The air receiver is provided with a safety valve.

The engine is equipped with low oil pressure and high oil temperature shut-down switches.

– Frame and axle

The compressor/engine unit is supported by rubber buffers in the frame.

The standard unit has a non-adjustable towbar with a towing eye.

As an option the unit can be equipped with an adjustable towbar, an overrun and parking brake and towing eyes type AC, DIN, ball, ITA, GB, NATO (for options see chapter 7).

The braking system consists of an integrated parking brake and overrunbrake. When driving backwards the overrunbrake is not engaged automatically.

– Bodywork

The bodywork has openings at the shaped front and rear end for the intake and outlet of cooling air and a hood for maintenance and service operations. The bodywork is internally lined with sound-absorbing material.

– Lifting eye

A lifting eye is accessible when the small door at the top of the unit is unlocked.

– Control panel

The control panel grouping the air pressure gauge, control switch etc., is placed in the center at the rear end.

– Data plate

The compressor is furnished with a data plate showing the product code, the unit number and the working pressure (see chapter 9).

– Serial number

The serial number is located on the right-hand front side of the frame.

– Generator (option for XAS 67 Dd and XAS 97 Dd)

The built-in generator is driven by a multi V-belt drive. The generated current can be drawn via 3 sockets (see chapter 8, Technical Specifications).

The compressor and the generator of the XAS 67 DdG / DdG IT may be used simultaneously. The compressor and the generator of the XAS 97 DdG / DdG IT may **not** be used simultaneously.

As an option the generator can be equipped with an automatic control system.

2.3 MARKINGS AND INFORMATION LABELS

	Compressor outlet temperature too high.
	Compressor outlet temperature.
	Compressor outlet pressure.
	Dangerous outlet.
	Danger, heat flat.
	Electrocution hazard.
	Atlas Copco mineral compressor oil.
	Atlas Copco synthetic compressor oil.
	Atlas Copco mineral engine oil.
	Manual.
	Read the instruction manual before working on the battery.
	Reset fuse.
	On / off button.
	Manual override switch.
	Hours, time.
	Prohibition to open air valves without connected hoses.
	Compressor loaded.
	Runlamp.
	Airfilter.
	Compressor temperature too high.
	Rotation direction.

	Inlet.
	Outlet.
	Compressor oil drain.
	Read the instruction manual before starting.
	Service every 24 hours.
	Warning! Part under pressure.
	Do not stand on outlet valves.
	Start-Stop indication of switch.
	Do not run the motor with open doors.
	Lifting permitted.
	Use diesel fuel only.
2.7 bar / 39 psi	Tyre pressure.
	Sound power level in accordance with Directive 2000/14/EC (expressed in dB (A)).
	Sound power level in accordance with Directive 2000/14/EC (expressed in dB (A)).
	Horizontal towbar position required in case of coupling.
	Earthing connections.
0 ⚡ 1	Generator 0 = OFF 1 = ON
	Insulation fault.

2.4 MAIN PARTS

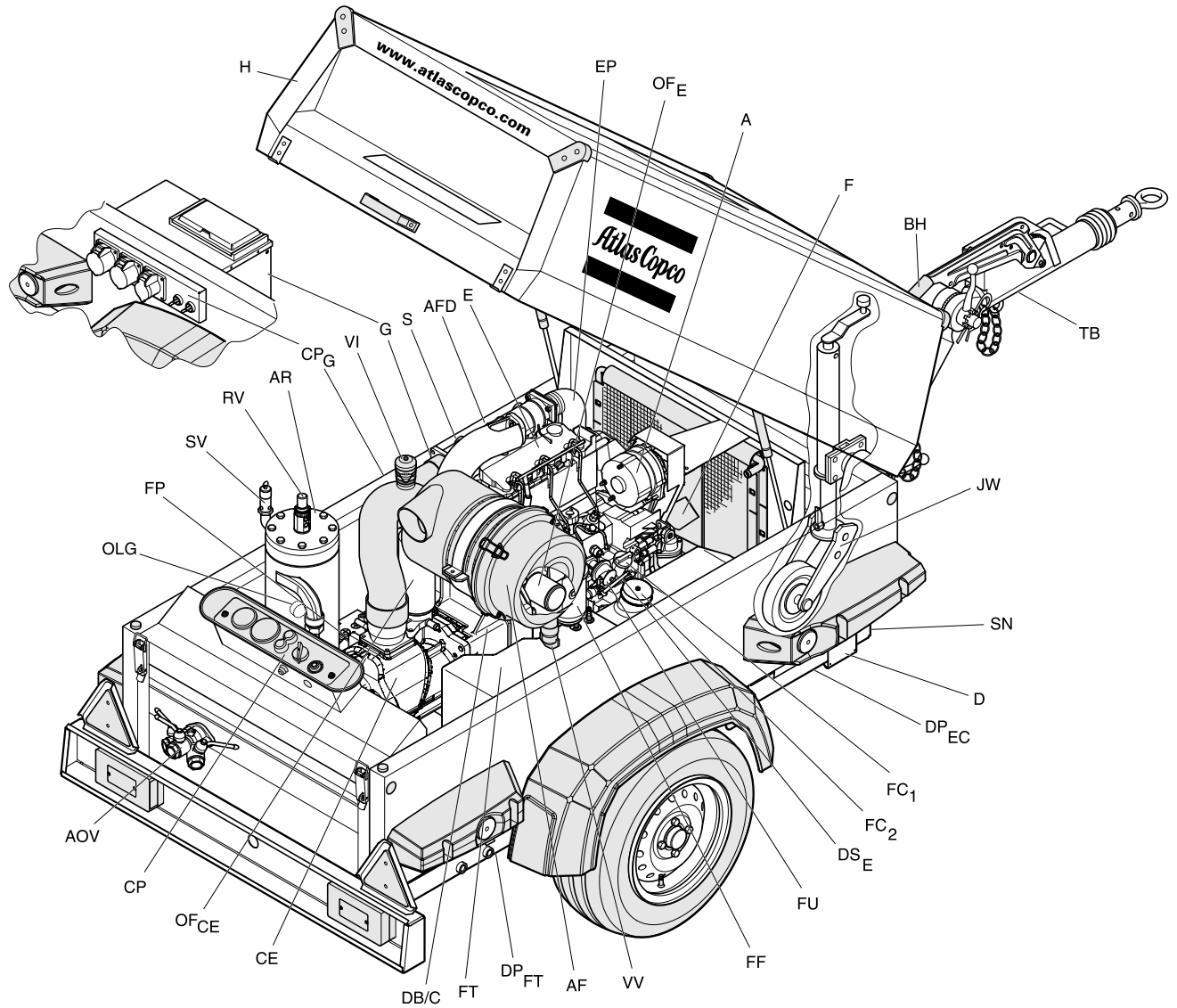
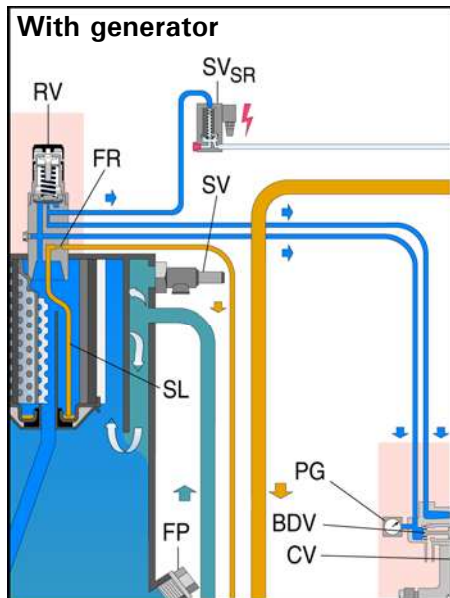
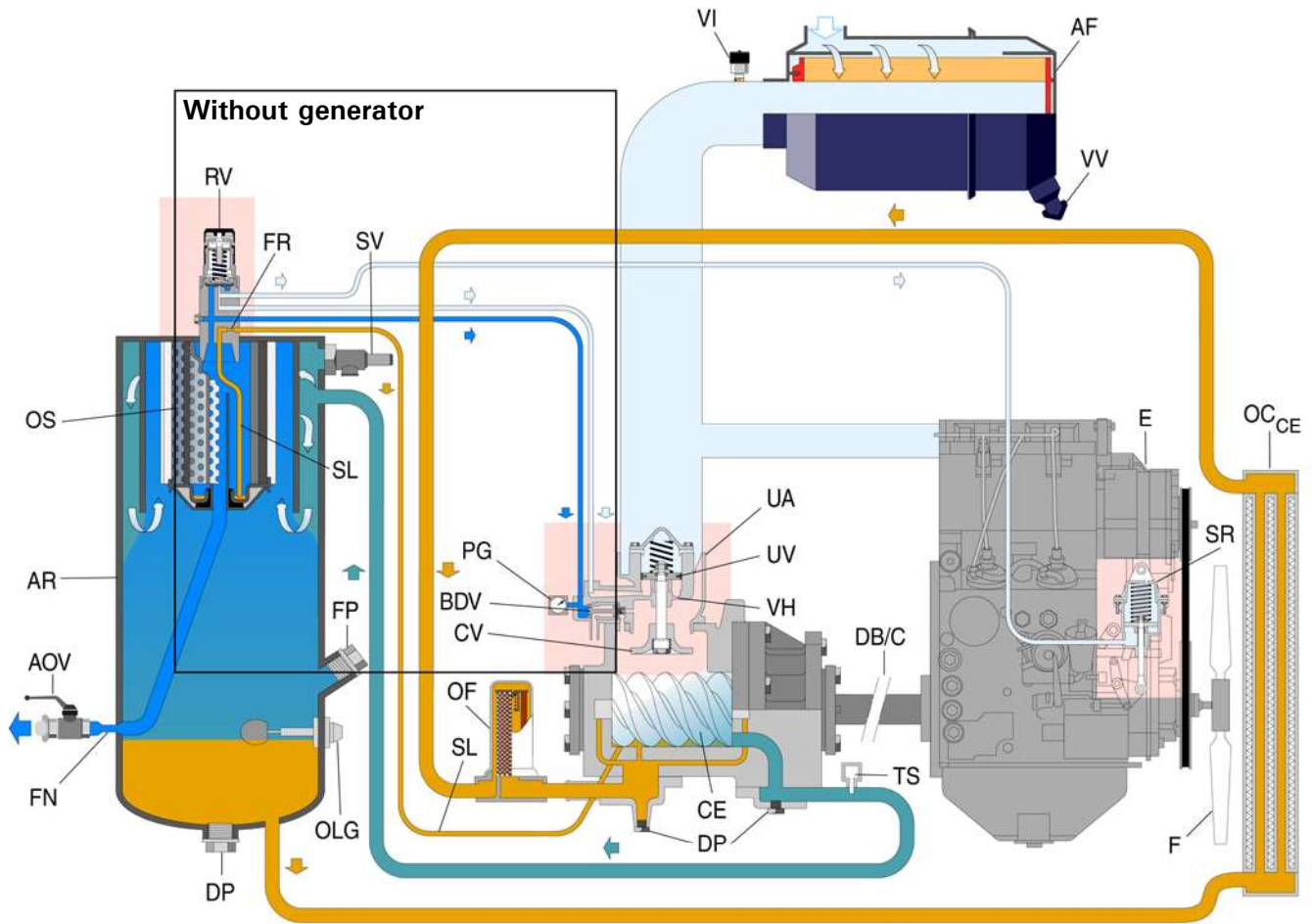

Fig. 2.2 Main parts with some options

A	Alternator	DP _{EC}	Drain Plug Engine Oil Cooler	H	Hood
AF	Air Filter	DP _{FT}	Drain Plug Fuel Tank	JW	Jockey wheel
AFD	Anti-Frost Device (option)	DS _E	Engine Oil Level Dipstick	OF _{CE}	Oil Filter (compressor element)
AOV	Air outlet valves	E	Engine	OF _E	Oil Filter (engine)
AR	Air Receiver	EP	Exhaust Pipe	OLG	Oil Level Gauge (compressor element)
BH	Brake Handle	F	Fan	RV	Regulating Valve
C	Coupling (XAS 77 Dd, XAS 97 Dd)	FC ₁	Filler Cap (engine oil)	S	Starting Motor
CE	Compressor Element	FC ₂	Filler Cap (fuel tank)	SN	Serial Number
CP	Control Panel	FF	Fuel Filter	SV	Safety Valve
CP _G	Control Panel (generator), (option)	FP	Filler Plug (compressor oil)	TB	Towbar
D	Data plate	FT	Fuel Tank	VI	Vacuum Indicator
DB	Drive Belt (XAS 67 Dd, XATS 67 Dd)	FU	Fuel Pump	VV	Vacuator Valve

COMPRESSOR REGULATING SYSTEM



67 DdG 6.5 kVA
67 DdG 12 kVA
97 DdG 6.5 kVA

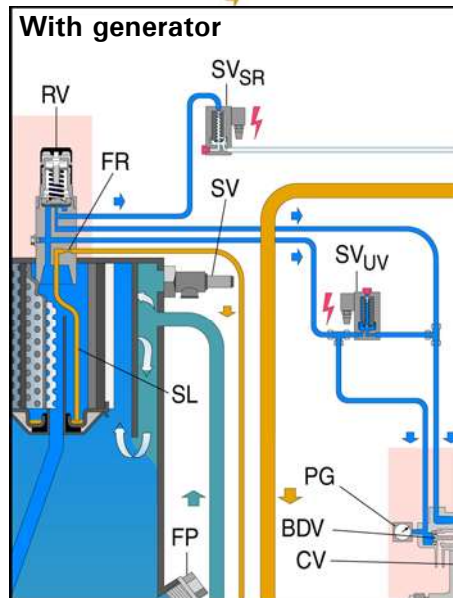

97 DdG 12 kVA

Fig. 2.3

AF	Air Filter	DP	Drain Plug	OS	Oil Separator	UV	Unloader Valve
AR	Air Receiver	E	Engine	PG	Pressure Gauge	VH	Vent Hole
AOV	Air Outlet Valves	F	Fan	RV	Regulating Valve	VI	Vacuum Indicator
BDV	Blow Down Valve	FN	Flow nozzle	SL	Scavenge Line	VV	Vacuator Valve
C	Coupling	FP	Filler Plug	SR	Speed Regulator		
CE	Compressor Element	FR	Flow Restrictor	SV	Safety Valve		
CV	Check Valve	OC _{CE}	Oil Cooler (compressor element)	SV _{SR}	Solenoid Valve (Speed regulator)		
DB	Drive Belt (XAS 67 Dd, XATS 67 Dd)	OF	Oil Filter	TS	Temperature Switch		
		OLG	Oil Level Gauge	UA	Unloader Assembly		

2.5 AIR FLOW (SEE FIG. 2.3)

The system comprises:

AF	Air filter
AR/OS	Air receiver/oil separator
CE	Compressor element
UA/UV	Unloader assembly with unloader valve
BDV	Blow-down valve
FN	Flow nozzle

Air drawn through the airfilter (AF) into the compressor element (CE) is compressed. At the element outlet, compressed air and oil pass into the air receiver/oil separator (AR/OS).

The check valve (CV) prevents blow-back of compressed air when the compressor is stopped. In the air receiver/oil separator (AR/OS), most of the oil is removed from the air/oil mixture; the remaining oil is removed by the separator element.

The oil collects in the receiver and on the bottom of the separator element.

The air leaves the receiver via a flow nozzle (FN) which prevents the receiver pressure from dropping below the minimum working pressure (specified in section 8.3), even when the air outlet valves are open. This ensures adequate oil injection and prevents oil consumption.

A temperature switch (TS) and a working pressure gauge (PG) are comprised in the system.

A blow-down valve (BDV) is fitted in the unloader assembly to automatically depressurise the air receiver (AR) when the compressor is stopped.

2.6 OIL SYSTEM (SEE FIG. 2.3)

The system comprises:

AR/OS	Air receiver/oil separator
OC _{CE}	Oil cooler
OF	Oil filter

The lower part of the air receiver (AR) serves as oil tank.

Air pressure forces the oil from the air receiver/oil separator (AR/OS) through the oil cooler (OC_{CE}) and oil filter (OF) to the compressor element (CE).

The compressor element has an oil gallery in the bottom of its casing. The oil for rotor lubrication, cooling and sealing is injected through holes in the gallery.

Lubrication of the bearings is ensured by oil injected into the bearing housings.

The injected oil, mixed with the compressed air, leaves the compressor element and re-enters the air receiver, where it is separated from the air as described in section 2.5. The oil that collects in the bottom of the oil separator element is returned to the system through a scavenging line (SL), which is provided with a flow restrictor (FR).

The oil filter by-pass valve opens when the pressure drop over the filter is above normal because of a clogged filter. The oil then by-passes the filter without being filtered. For this reason, the oil filter must be replaced at regular intervals (see section 4.2).

When cold start equipment is installed; a thermostatic valve will bypass the compressor oil (oil will not pass through oil cooler OC_{CE}), until the working temperature is reached.

2.7 CONTINUOUS REGULATING SYSTEM (SEE FIG. 2.3)

The system comprises:

RV	Regulating valve
UA	Unloader assembly
SR	Speed regulator

The compressor is provided with a continuous regulating system. This system is provided with a blow-down valve which is integrated in the unloader assembly (UA). The valve is closed during operation by outlet pressure of the compressor element and opens by air receiver pressure when the compressor is stopped.

When the air consumption increases, the air receiver pressure will decrease and vice versa. This receiver pressure variation is sensed by the regulating valve which, by means of control air to the unloader, matches the air output to the air consumption. The air receiver pressure is maintained between the pre-selected working pressure and the corresponding unloading pressure.

When starting the compressor, the unloader valve (UV) is kept open by spring force, the engine runs at maximum speed. The compressor element (CE) takes in air and pressure builds up in the receiver (AR).

The air output is controlled from maximum output (100%) to no output (0%) by:

1. Speed control of the engine between maximum load speed and unloading speed (the output of a screw compressor is proportional to the rotating speed).
2. Air inlet throttling.

If the air consumption is equal to or exceeds the maximum air output, the engine speed is held at maximum load speed and the unloading valve is fully open.

If the air consumption is less than the maximum air output, the regulating valve supplies control air to unloader valve (UV) to reduce the air output and holds air receiver pressure between the normal working pressure and the corresponding unloading pressure of approx. 1.5 bar above the normal working pressure.

When the air consumption is resumed, the unloader valve (UV) gradually opens the air intake and the speed regulator (SR) increases the engine speed.

The construction of the regulating valve (RV) is such that any increase (decrease) of the air receiver pressure above the pre-set valve opening pressure results in a proportional increase (decrease) of the control pressure to the unloading valve and the speed regulator.

Part of the control air is vented to the atmosphere, and any condensate discharged, through the vent holes (VH).

Generator

When the generator is switched on, the solenoid valve (SV_{SR}) via the speed regulator (SR) controls the engine and allows it to reach maximum speed (the normal control system is switched off).

2.8 ELECTRICAL SYSTEM

2.8.1 CIRCUIT DIAGRAM (STANDARD)

The compressor is equipped with a negative earthed system.

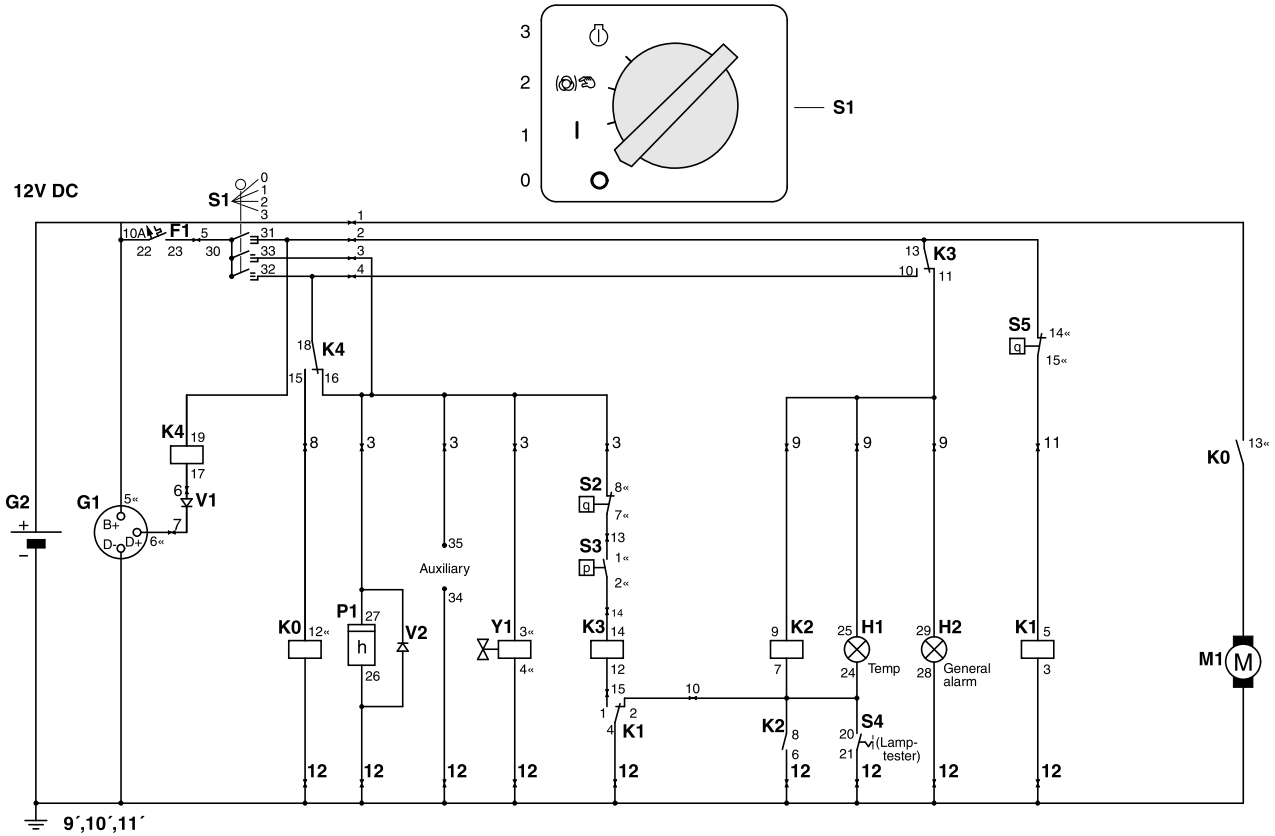

Fig. 2.4 Circuit diagram (No. 9822 0797 01)

F1	Circuit Breaker (10 A)	M1	Starter Motor
G1	Alternator	P1	Hourmeter
G2	Battery	S1	Contact Switch (Off-On-Override-start)
H1	Temperature Alarm Lamp	S2	Temperature Switch Engine
H2	General Alarm Lamp	S3	Oil Pressure Switch Engine
K0	Starter Solenoid (part of M1)	S4	Lamp-tester Switch
K1	Shut-down Relay	S5	Temperature Switch Compressor
K2	Blocking Relay	Y1	Fuel Solenoid Valve
K3	Override Start Relay	V1	Diode
K4	Start Relay	V2	Diode

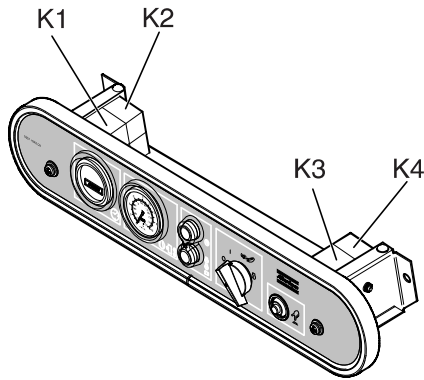

Fig. 2.5 Location of relays K1-K4

Operation of the electric circuit in detail

Start switch S1 position 1:

Line 2 on 12V contact K3 closed (13-11), lamp H2 is on. K4 excites contact K4 (18-15). Thermocontact element S5 normally closed, K1 excites contact K1 (1-4).

Use of lamp test:

Start switch S1 position 1 press lamp test S4, across K3 and line 9 lamp H1 and relay K2 are excited. After releasing lamp test button S4, lamp H1 remains on, S4 taken over by contact K2.

Start switch S1 position 2:

Line 3 on 12V (overwrite function) hourmeter P1 and fuel solenoid Y1 excited. Thermocontact engine S2 normally closed, oil pressure contact S3 open.

Start switch S1 position 3:

Start relay K0 is excited and starter motor is running, engine builds up oil pressure and oil pressure contact S3 closes. K3 excited and contact K3 changes over to (13-10). Relay K2 no longer excited, contact K2 opens, lamp H1 goes out. Alternator also commences supplying voltage and K4 is no longer excited and contact K4 changes over to (18-16). Lamp H2 goes out, one can release start switch S1 and it returns to position 1. Exciting the safety devices occurs no longer across line 3 but across line 2 to line 4 and this way to line 3.

Engine is running normally:

Oil pressure contact S3 opens, K3 no longer excited. K3 changes over (13-11), engine cuts out because fuel solenoid Y1 no longer excited and lamp H2 goes on simultaneously.

Thermocontact S2 opens, K3 no longer excited. K3 changes over (13-11), engine cuts out because fuel solenoid Y1 no longer excited and lamp H2 goes on simultaneously.

Thermocontact S5 opens, K1 no longer excited. Contact K1 changes over (4-2). K3 no longer excited. K3 changes over (13-11), engine cuts out because fuel solenoid Y1 no longer excited and lamp H2 and H1 go on simultaneously. Take-over relay K2 is excited simultaneously with H1 and contact K2 closes (8-6).

Thermocontact S5 cools off and closes, K1 excited again and contact K1 changes over (4-1). However, lamp H1 remains on across line 9 and contact K2 (6-8).

A fault in the alternator part causes terminal D+ to go to 0V and K4 to be excited. Contact K4 changes over to (18-15), engine cuts out because fuel solenoid Y1 no longer excited and lamp H2 goes on simultaneously.

Machine Verhuur Oosterwolde

**2.8.2 CIRCUIT DIAGRAM XAS 67 DdG, XAS 97 DdG
(GENERATOR DdG 110V WITHOUT AUTOMATIC CONTROL SYSTEM)
(Option; no hardhat)**

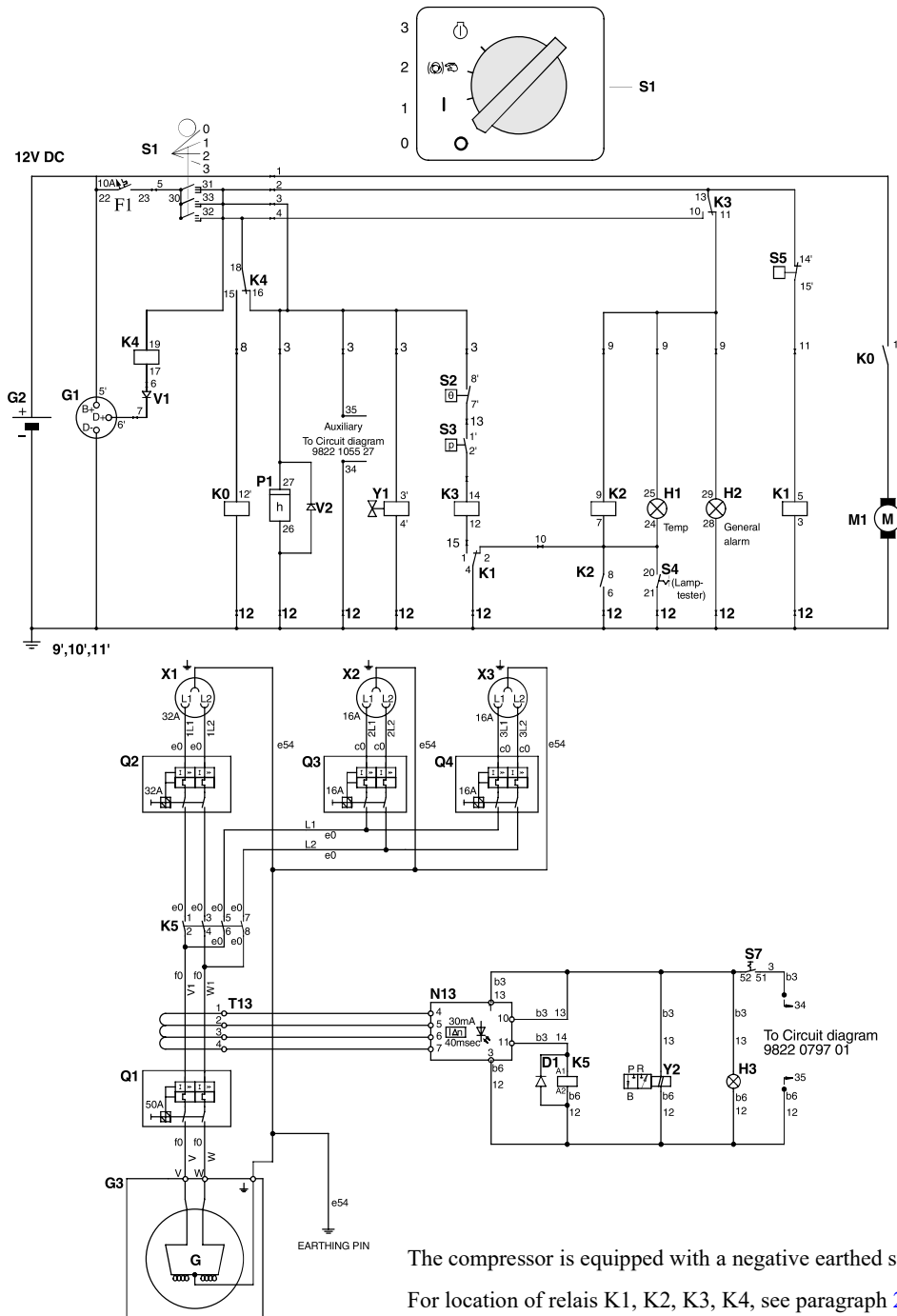

The compressor is equipped with a negative earthed system
For location of relays K1, K2, K3, K4, see paragraph 2.8.1

Fig. 2.6 Circuit diagram (No. 9822 0797 01 + No. 9822 1055 27)

D1	Diode	K2	Blocking Relay	Q4	Circuit breaker 2-pole	V1	Diode
F1	Circuit Breaker (10A)	K3	Override Start Relay	S1	Contact Switch (Off-On-Override-start)	V2	Diode
G1	Alternator	K4	Start Relay	S2	Temperature Switch Engine	X1	Socket outlet
G2	Battery	K5	Contactor	S3	Oil Pressure Switch Engine	X2	Socket outlet
G3	Generator	M1	Starter Motor	S4	Lamp-test Switch	X3	Socket outlet
H1	Temperature Alarm Lamp	N13	Earth faultcurrent relay	S5	Temperature Switch Compressor	Y1	Fuel solenoid Valve
H2	General Alarm Lamp	P1	Hourmeter	S7	Switch (Generator-compressor)	Y2	Solenoid valve (Generator action)
H3	Lamp (Power ON)	Q1	Main circuit breaker 2-pole	T13	Current transformer for N13		
K0	Starter Solenoid (part of M1)	Q2	Circuit breaker 2-pole				
K1	Shut-down Relay	Q3	Circuit breaker 2-pole				

Operation of the electric circuit in detail

Start switch S1 position 1:

Line 2 on 12V contact K3 closed (13-11), lamp H2 is on. K4 excites contact K4 (18-15). Thermocontact element S5 normally closed, K1 excites contact K1 (1-4).

Use of lamp test:

Start switch S1 position 1 press lamp test S4, across K3 and line 9 lamp H1 and relay K2 are excited. After releasing lamp test button S4, lamp H1 remains on, S4 taken over by contact K2.

Start switch S1 position 2:

Line 3 on 12V (overwrite function) hourmeter P1 and fuel solenoid Y1 excited. Thermocontact engine S2 normally closed, oil pressure contact S3 open.

Start switch S1 position 3:

Start relay K0 is excited and starter motor is running, engine builds up oil pressure and oil pressure contact S3 closes. K3 excited and contact K3 changes over to (13-10). Relay K2 no longer excited, contact K2 opens, lamp H1 goes out. Alternator also commences supplying voltage and K4 is no longer excited and contact K4 changes over to (18-16). Lamp H2 goes out, one can release start switch S1 and it returns to position 1. Exciting the safety devices occurs no longer across line 3 but across line 2 to line 4 and this way to line 3.

Engine is running normally:

Oil pressure contact S3 opens, K3 no longer excited. K3 changes over (13-11), engine cuts out because fuel solenoid Y1 no longer excited and lamp H2 goes on simultaneously.

Thermocontact S2 opens, K3 no longer excited. K3 changes over (13-11), engine cuts out because fuel solenoid Y1 no longer excited and lamp H2 goes on simultaneously.

Thermocontact S5 opens, K1 no longer excited. Contact K1 changes over (4-2). K3 no longer excited. K3 changes over (13-11), engine cuts out because fuel solenoid Y1 no longer excited and lamp H2 and H1 go on simultaneously. Take-over relay K2 is excited simultaneously with H1 and contact K2 closes (8-6).

Thermocontact S5 cools off and closes, K1 excited again and contact K1 changes over (4-1). However, lamp H1 remains on across line 9 and contact K2 (6-8).

A fault in the alternator part causes terminal D+ to go to 0V and K4 to be excited. Contact K4 changes over to (18-15), engine cuts out because fuel solenoid Y1 no longer excited and lamp H2 goes on simultaneously.

Generator function:

Turn switch S7 to position 1. The solenoid valve Y2 via the speed regulator SR controls the motor and allows it to reach maximum speed (the normal control system is switched off). Lamp H3 is activated and sockets X1, X2, X3 are under tension.

The generator can be switched off by turning switch S7 to position 0.

An insulation fault is detected when a leakage current is flowing. Contactor K5 will no longer be excited through the earth faultcurrent relay N13.

**2.8.3 CIRCUIT DIAGRAM XAS 67 DdG, XAS 97 DdG
(GENERATOR DdG 110V WITH AUTOMATIC CONTROL SYSTEM)**
(Option; no hardhat)

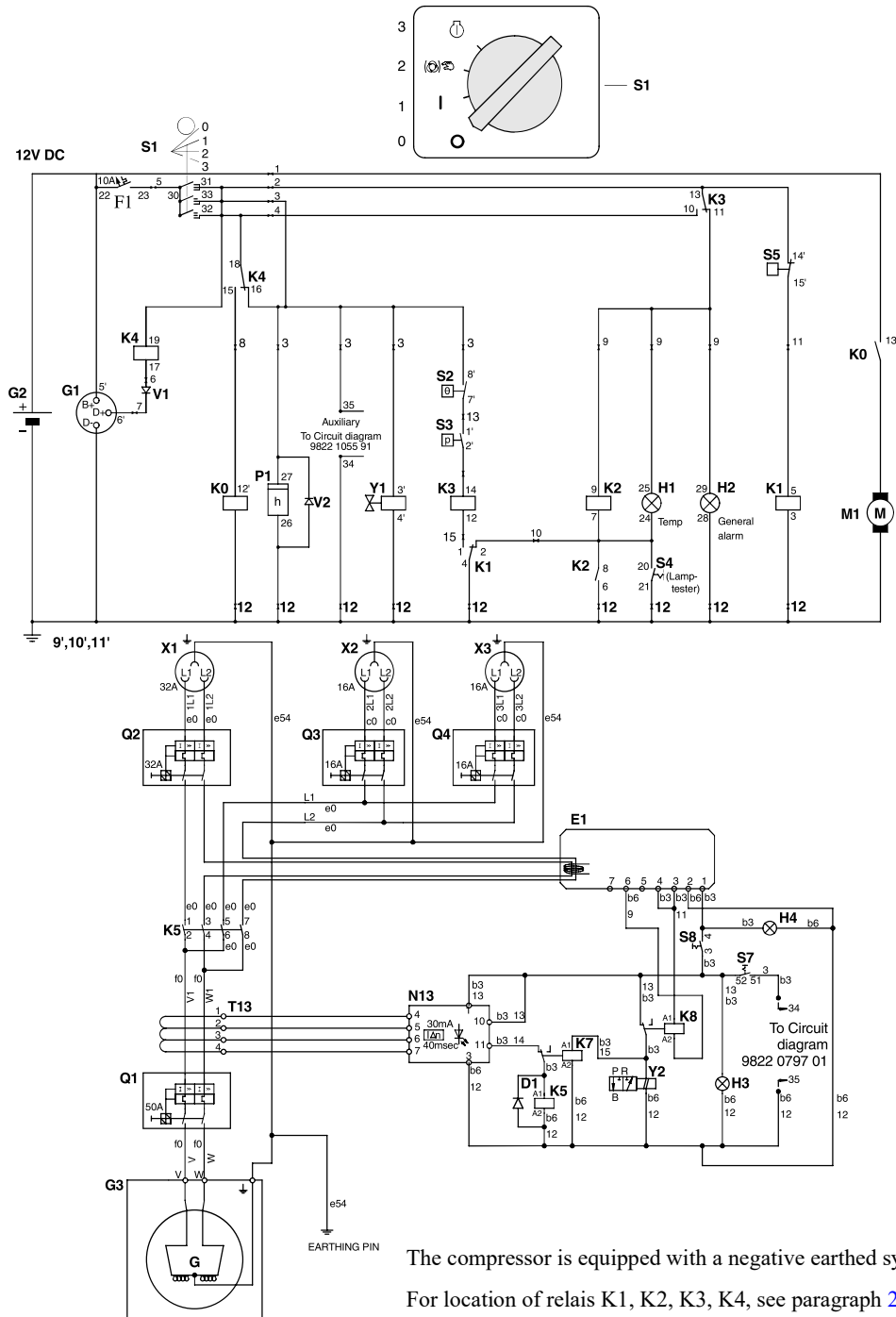

The compressor is equipped with a negative earthed system.

For location of relays K1, K2, K3, K4, see paragraph 2.8.1

Fig. 2.7 Circuit diagram (No. 9822 0797 01 + No. 9822 1055 91)

D1	Diode	K1	Shut-down Relay	Q2	Circuit breaker 2-pole	S8	Switch automatic control system
E1	Ecologiser	K2	Blocking Relay	Q3	Circuit breaker 2-pole	T13	Current transformer for N13
F1	Circuit Breaker (10A)	K3	Override Start Relay	Q4	Circuit breaker 2-pole	V1	Diode
G1	Alternator	K4	Start Relay	S1	Contact Switch (Off-On-Override-start)	V2	Diode
G2	Battery	K5	Contactora	S2	Temperature Switch Engine	X1	Socket outlet
G3	Generator	K7	Time relays	S3	Oil Pressure Switch Engine	X2	Socket outlet
H1	Temperature Alarm Lamp	K8	Time relays	S4	Lamp-tester Switch	X3	Socket outlet
H2	General Alarm Lamp	M1	Starter Motor	S5	Temperature Switch	Y1	Fuel solenoid Valve
H3	Lamp (Power ON)	N13	Earth faultcurrent relay	S7	Switch (Generator-compressor)	Y2	Solenoid valve (Generator action)
H4	Lamp automatic control system	Q1	Main circuit breaker 2-pole				
K0	Starter Solenoid (part of M1)						

Operation of the electric circuit in detail

Start switch S1 position 1:

Line 2 on 12V contact K3 closed (13-11), lamp H2 is on. K4 excites contact K4 (18-15). Thermocontact element S5 normally closed, K1 excites contact K1 (1-4).

Use of lamp test:

Start switch S1 position 1 press lamp test S4, across K3 and line 9 lamp H1 and relay K2 are excited. After releasing lamp test button S4, lamp H1 remains on, S4 taken over by contact K2.

Start switch S1 position 2:

Line 3 on 12V (overwrite function) hourmeter P1 and fuel solenoid Y1 excited. Thermocontact engine S2 normally closed, oil pressure contact S3 open.

Start switch S1 position 3:

Start relay K0 is excited and starter motor is running, engine builds up oil pressure and oil pressure contact S3 closes. K3 excited and contact K3 changes over to (13-10). Relay K2 no longer excited, contact K2 opens, lamp H1 goes out. Alternator also commences supplying voltage and K4 is no longer excited and contact K4 changes over to (18-16). Lamp H2 goes out, one can release start switch S1 and it returns to position 1. Exciting the safety devices occurs no longer across line 3 but across line 2 to line 4 and this way to line 3.

Engine is running normally:

Oil pressure contact S3 opens, K3 no longer excited. K3 changes over (13-11), engine cuts out because fuel solenoid Y1 no longer excited and lamp H2 goes on simultaneously.

Thermocontact S2 opens, K3 no longer excited. K3 changes over (13-11), engine cuts out because fuel solenoid Y1 no longer excited and lamp H2 goes on simultaneously.

Thermocontact S5 opens, K1 no longer excited. Contact K1 changes over (4-2). K3 no longer excited. K3 changes over (13-11), engine cuts out because fuel solenoid Y1 no longer excited and lamp H2 and H1 go on simultaneously. Take-over relay K2 is excited simultaneously with H1 and contact K2 closes (8-6).

Thermocontact S5 cools off and closes, K1 excited again and contact K1 changes over (4-1). However, lamp H1 remains on across line 9 and contact K2 (6-8).

A fault in the alternator part causes terminal D+ to go to 0V and K4 to be excited. Contact K4 changes over to (18-15), engine cuts out because fuel solenoid Y1 no longer excited and lamp H2 goes on simultaneously.

Generator function:

Turn switch S7 to position 1. The solenoid valve Y2 via the speed regulator SR controls the motor and allows it to reach maximum speed (the normal control system is switched off). Lamp H3 is activated. Time relay K7 disconnects the sockets from the generator during 4 sec, after which the sockets X1, X2, X3 are under tension.

The generator can be switched off by turning switch S7 to position 0.

If switch S7 is turned on, lamp H4 and ecologiser E1 are activated. E1 senses continuously the current to the sockets. If no current is sensed, time relay K8 is activated. This time relay deactivates the solenoid valve Y2 so that the speed regulator is again controlled by the normal compressor control system. When in this condition E1 senses current to the sockets, the solenoid valve Y2 is re-activated immediately by K8. Time relay K7 disconnects the sockets from the generator during 4 sec, after which the sockets X1, X2, X3 are under tension.

**2.8.4 CIRCUIT DIAGRAM XAS 67 DdG, XAS 97 DdG
(GENERATOR DdG IT 230/400V, 6 kVA WITHOUT AUTOMATIC CONTROL SYSTEM)
(Option; no hardhat)**

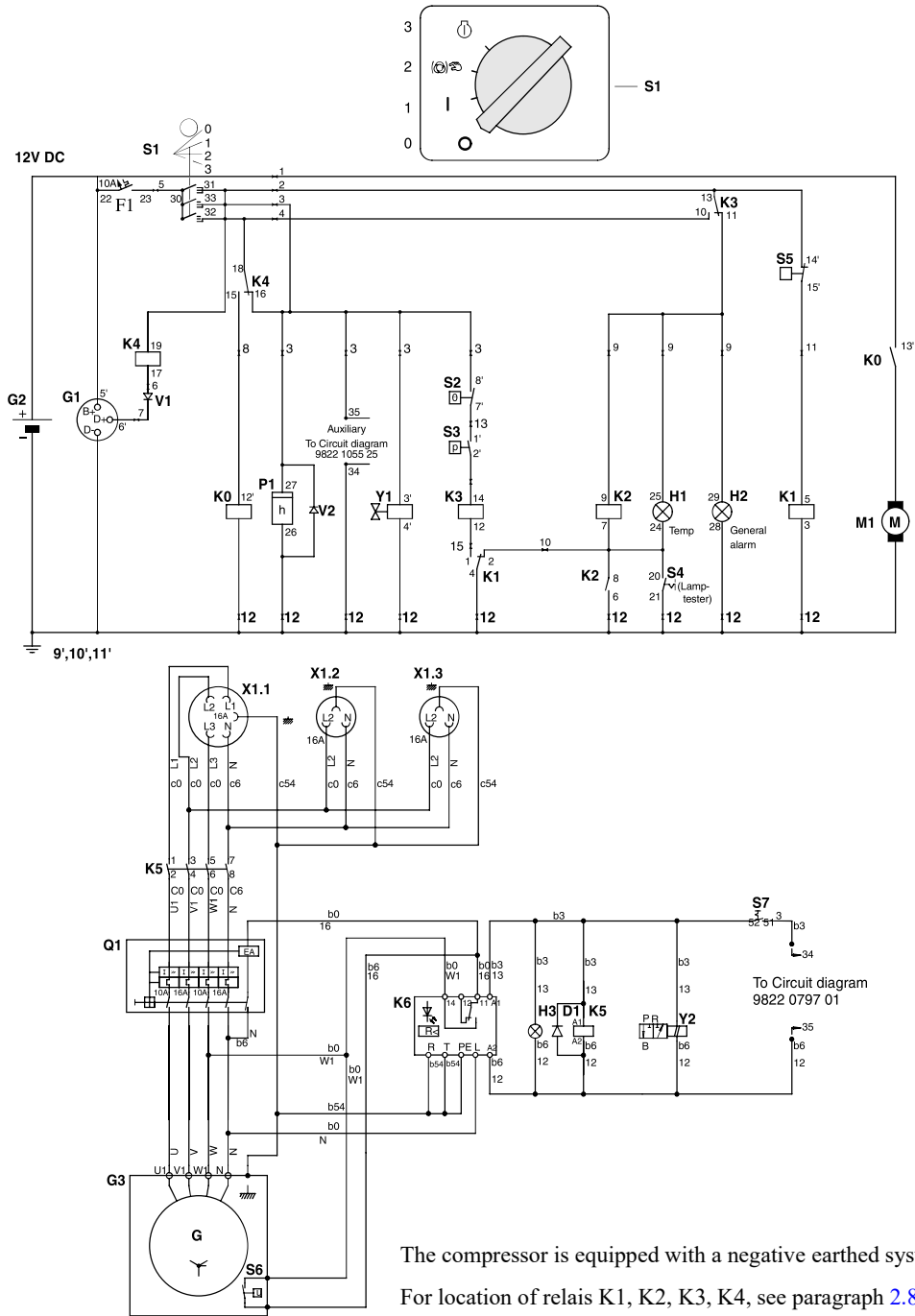

The compressor is equipped with a negative earthed system.
For location of relays K1, K2, K3, K4, see paragraph 2.8.1

Fig. 2.8 Circuit diagram (No. 9822 0797 01 + No. 9822 1055 25)

D1 Diode	K2 Blocking Relay	S1 Contact Switch	X1.1 Socket outlet
F1 Circuit Breaker (10 A)	K3 Override Start Relay	(Off-On-Override-start)	X1.2 Socket outlet
G1 Alternator	K4 Start Relay	S2 Temperature Switch Engine	X1.3 Socket outlet
G2 Battery	K5 Contactor/4-pole	S3 Oil Pressure Switch Engine	Y1 Fuel solenoid Valve
G3 Generator	K6 Insulation monitoring relay	S4 Lamptester Switch	Y2 Solenoid valve
H1 Temperature Alarm Lamp	M1 Starter Motor	S5 Temperature Switch Compressor	(Generator action)
H2 General Alarm Lamp	P1 Hourmeter	S6 Thermalcontact	
H3 Lamp (Power Control)	Q1 Main circuit breaker 4-pole + shunt tripcoil	S7 Switch (Generator-compressor)	
K0 Starter Solenoid (part of M1)		V1 Diode	
K1 Shut-down Relay		V2 Diode	

Operation of the electric circuit in detail

Start switch S1 position 1:

Line 2 on 12V contact K3 closed (13-11), lamp H2 is on. K4 excites contact K4 (18-15). Thermocontact element S5 normally closed, K1 excites contact K1 (1-4).

Use of lamp test:

Start switch S1 position 1 press lamp test S4, across K3 and line 9 lamp H1 and relay K2 are excited. After releasing lamp test button S4, lamp H1 remains on, S4 taken over by contact K2.

Start switch S1 position 2:

Line 3 on 12V (overwrite function) hourmeter P1 and fuel solenoid Y1 excited. Thermocontact engine S2 normally closed, oil pressure contact S3 open.

Start switch S1 position 3:

Start relay K0 is excited and starter motor is running, engine builds up oil pressure and oil pressure contact S3 closes. K3 excited and contact K3 changes over to (13-10). Relay K2 no longer excited, contact K2 opens, lamp H1 goes out. Alternator also commences supplying voltage and K4 is no longer excited and contact K4 changes over to (18-16). Lamp H2 goes out, one can release start switch S1 and it returns to position 1. Exciting the safety devices occurs no longer across line 3 but across line 2 to line 4 and this way to line 3.

Engine is running normally:

Oil pressure contact S3 opens, K3 no longer excited. K3 changes over (13-11), engine cuts out because fuel solenoid Y1 no longer excited and lamp H2 goes on simultaneously.

Thermocontact S2 opens, K3 no longer excited. K3 changes over (13-11), engine cuts out because fuel solenoid Y1 no longer excited and lamp H2 goes on simultaneously.

Thermocontact S5 opens, K1 no longer excited. Contact K1 changes over (4-2). K3 no longer excited. K3 changes over (13-11), engine cuts out because fuel solenoid Y1 no longer excited and lamp H2 and H1 go on simultaneously. Take-over relay K2 is excited simultaneously with H1 and contact K2 closes (8-6).

Thermocontact S5 cools off and closes, K1 excited again and contact K1 changes over (4-1). However, lamp H1 remains on across line 9 and contact K2 (6-8).

A fault in the alternator part causes terminal D+ to go to 0V and K4 to be excited. Contact K4 changes over to (18-15), engine cuts out because fuel solenoid Y1 no longer excited and lamp H2 goes on simultaneously.

Generator function:

Turn switch S7 to position 1. The solenoid valve Y2 via the speed regulator SR controls the motor and allows it to reach maximum speed (the normal control system is switched off). Lamp H3 is activated and sockets X1.1, X1.2, X1.3 are under tension.

The generator can be switched off by turning switch S7 to position 0.

In the case of an insulation fault, the yellow LED on the insulation monitoring relay K6 of the system is activated. When the yellow LED of K6 is active, a reset can only occur by halting and restarting the assembly.

**2.8.5 CIRCUIT DIAGRAM XAS 67 DdG, XAS 97 DdG
(GENERATOR DdG IT 230/400V, 6 kVA WITH AUTOMATIC CONTROL SYSTEM)**
(Option; no hardhat)

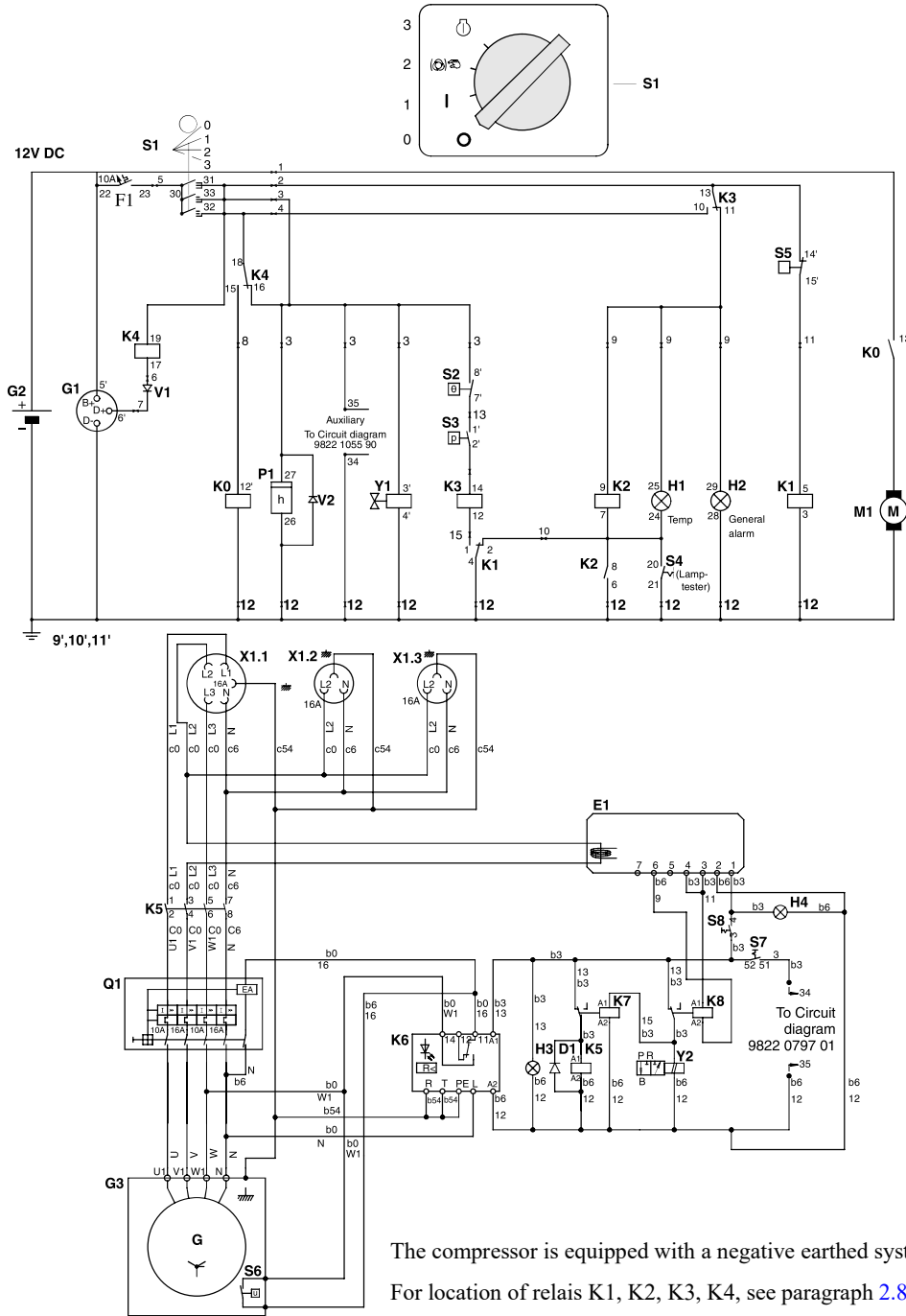

The compressor is equipped with a negative earthed system.
For location of relays K1, K2, K3, K4, see paragraph 2.8.1

Fig. 2.9 Circuit diagram (No. 9822 0797 01 + No. 9822 1055 90)

D1	Diode	K2	Blocking Relay	S1	Contact Switch (Off-On-Override-start)	V1	Diode
E1	Ecologiser	K3	Override Start Relay	S2	Temperature Switch Engine	V2	Diode
F1	Circuit Breaker (10 A)	K4	Start Relay	S3	Oil Pressure Switch Engine	X1.1	Socket outlet
G1	Alternator	K5	Contactor/4-pole	S4	Lamp-tester Switch	X1.2	Socket outlet
G2	Battery	K6	Insulation monitoring relay	S5	Temperature Switch Compressor	X1.3	Socket outlet
G3	Generator	K7	Time relays	S6	Thermalcontact	Y1	Fuel solenoid Valve (Generator action)
H1	Temperature Alarm Lamp	K8	Time relays	S7	Switch (Generator- compressor)	Y2	Solenoid valve (Generator action)
H2	General Alarm Lamp	M1	Starter Motor	S8	Switch automatic control system		
H3	Lamp (Power Control)	P1	Hourmeter				
H4	Lamp automatic control system	Q1	Main circuit breaker 4-pole + shunt tripcoil				
K0	Starter Solenoid (part of M1)						
K1	Shut-down Relay						

Operation of the electric circuit in detail

Start switch S1 position 1:

Line 2 on 12V contact K3 closed (13-11), lamp H2 is on. K4 excites contact K4 (18-15). Thermocontact element S5 normally closed, K1 excites contact K1 (1-4).

Use of lamp test:

Start switch S1 position 1 press lamp test S4, across K3 and line 9 lamp H1 and relay K2 are excited. After releasing lamp test button S4, lamp H1 remains on, S4 taken over by contact K2.

Start switch S1 position 2:

Line 3 on 12V (overwrite function) hourmeter P1 and fuel solenoid Y1 excited. Thermocontact engine S2 normally closed, oil pressure contact S3 open.

Start switch S1 position 3:

Start relay K0 is excited and starter motor is running, engine builds up oil pressure and oil pressure contact S3 closes. K3 excited and contact K3 changes over to (13-10). Relay K2 no longer excited, contact K2 opens, lamp H1 goes out. Alternator also commences supplying voltage and K4 is no longer excited and contact K4 changes over to (18-16). Lamp H2 goes out, one can release start switch S1 and it returns to position 1. Exciting the safety devices occurs no longer across line 3 but across line 2 to line 4 and this way to line 3.

Engine is running normally:

Oil pressure contact S3 opens, K3 no longer excited. K3 changes over (13-11), engine cuts out because fuel solenoid Y1 no longer excited and lamp H2 goes on simultaneously.

Thermocontact S2 opens, K3 no longer excited. K3 changes over (13-11), engine cuts out because fuel solenoid Y1 no longer excited and lamp H2 goes on simultaneously.

Thermocontact S5 opens, K1 no longer excited. Contact K1 changes over (4-2). K3 no longer excited. K3 changes over (13-11), engine cuts out because fuel solenoid Y1 no longer excited and lamp H2 and H1 go on simultaneously. Take-over relay K2 is excited simultaneously with H1 and contact K2 closes (8-6).

Thermocontact S5 cools off and closes, K1 excited again and contact K1 changes over (4-1). However, lamp H1 remains on across line 9 and contact K2 (6-8).

A fault in the alternator part causes terminal D+ to go to 0V and K4 to be excited. Contact K4 changes over to (18-15), engine cuts out because fuel solenoid Y1 no longer excited and lamp H2 goes on simultaneously.

Generator function:

Turn switch S7 to position 1. The solenoid valve Y2 via the speed regulator SR controls the motor and allows it to reach maximum speed (the normal control system is switched off). Lamp H3 is activated. Time relay K7 disconnects the sockets from the generator during 4 sec, after which the sockets X1.1, X1.2, X1.3 are under tension.

The generator can be switched off by turning switch S7 to position 0.

If switch S7 is turned on, lamp H4 and ecologiser E1 are activated. E1 senses continuously the current to the sockets. If no current is sensed, time relay K8 is activated. This time relay deactivates the solenoid valve Y2 so that the speed regulator is again controlled by the normal compressor control system. When in this condition E1 senses current to the sockets, the solenoid valve Y2 is re-activated immediately by K8. Time relay K7 disconnects the sockets from the generator during 4 sec, after which the sockets X1, X2, X3 are under tension.

**2.8.6 CIRCUIT DIAGRAM XAS 67 DdG, XAS 97 DdG
(GENERATOR DdG IT 230V, 6 kVA)
(Option; no hardhat)**

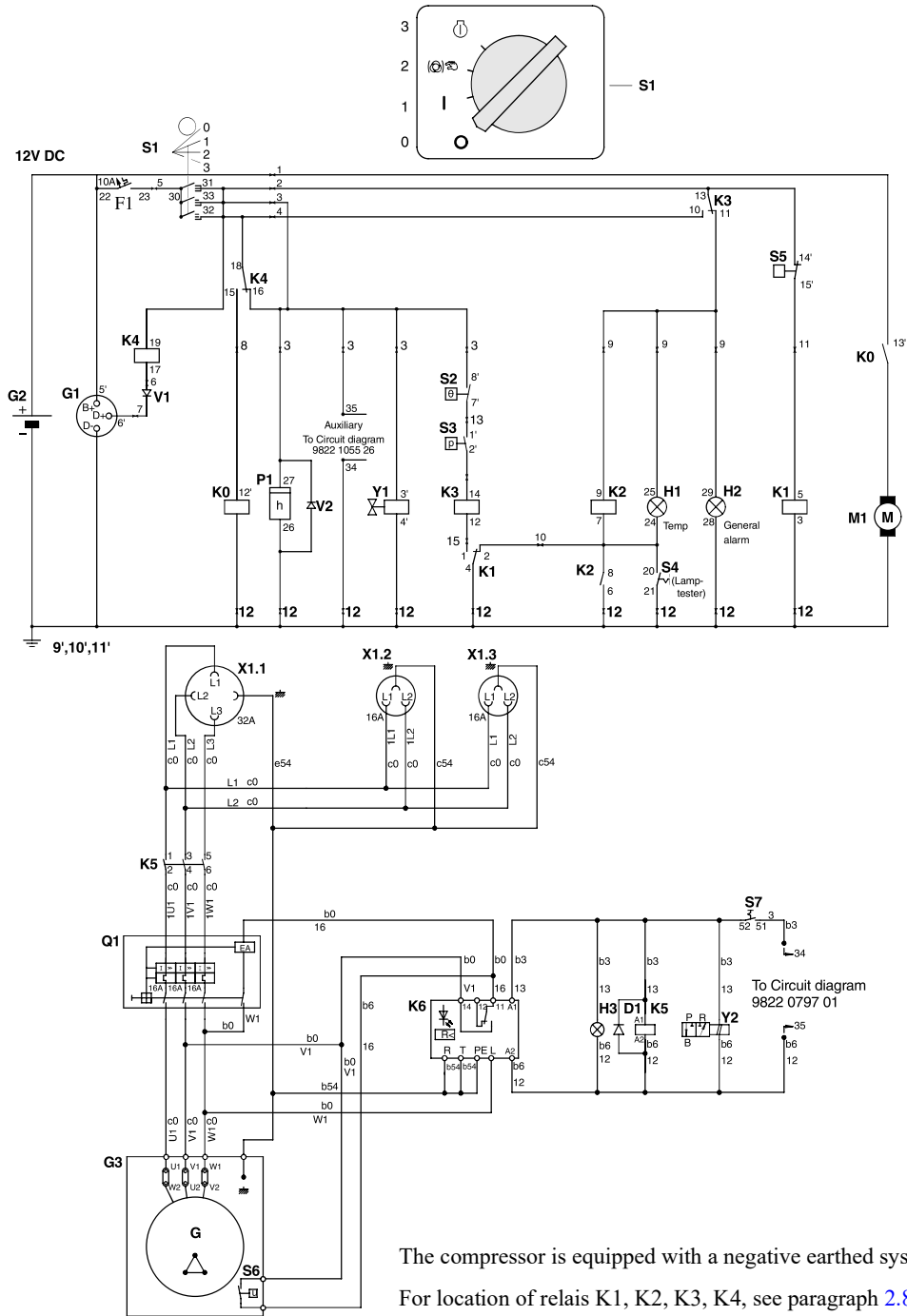

The compressor is equipped with a negative earthed system.
For location of relays K1, K2, K3, K4, see paragraph 2.8.1

Fig. 2.10 Circuit diagram (No. 9822 0797 01 + No. 9822 1055 26)

D1	Diode	K2	Blocking Relay	S1	Contact Switch (Off-On-Override-start)	V1	Diode
F1	Circuit Breaker (10 A)	K3	Override Start Relay	S2	Temperature Switch Engine	V2	Diode
G1	Alternator	K4	Start Relay	S3	Oil Pressure Switch Engine	X1.1	Socket outlet
G2	Battery	K5	Contact/4-pole	S4	Lampstest Switch	X1.2	Socket outlet
G3	Generator	K6	Insulation monitoring relay	S5	Temperature Switch Compressor	X1.3	Socket outlet
H1	Temperature Alarm Lamp	M1	Starter Motor	S6	Thermalcontact	Y1	Fuel solenoid Valve (Generator action)
H2	General Alarm Lamp	P1	Hourmeter	S7	Switch (Generator-compressor)	Y2	Solenoid valve (Generator action)
H3	Lamp (Power Control)	Q1	Main circuit breaker 3-pole + shunt tripcoil				
K0	Starter Solenoid (part of M1)						
K1	Shut-down Relay						

Operation of the electric circuit in detail

Start switch S1 position 1:

Line 2 on 12V contact K3 closed (13-11), lamp H2 is on. K4 excites contact K4 (18-15). Thermocontact element S5 normally closed, K1 excites contact K1 (1-4).

Use of lamp test:

Start switch S1 position 1 press lamp test S4, across K3 and line 9 lamp H1 and relay K2 are excited. After releasing lamp test button S4, lamp H1 remains on, S4 taken over by contact K2.

Start switch S1 position 2:

Line 3 on 12V (overwrite function) hourmeter P1 and fuel solenoid Y1 excited. Thermocontact engine S2 normally closed, oil pressure contact S3 open.

Start switch S1 position 3:

Start relay K0 is excited and starter motor is running, engine builds up oil pressure and oil pressure contact S3 closes. K3 excited and contact K3 changes over to (13-10). Relay K2 no longer excited, contact K2 opens, lamp H1 goes out. Alternator also commences supplying voltage and K4 is no longer excited and contact K4 changes over to (18-16). Lamp H2 goes out, one can release start switch S1 and it returns to position 1. Exciting the safety devices occurs no longer across line 3 but across line 2 to line 4 and this way to line 3.

Engine is running normally:

Oil pressure contact S3 opens, K3 no longer excited. K3 changes over (13-11), engine cuts out because fuel solenoid Y1 no longer excited and lamp H2 goes on simultaneously.

Thermocontact S2 opens, K3 no longer excited. K3 changes over (13-11), engine cuts out because fuel solenoid Y1 no longer excited and lamp H2 goes on simultaneously.

Thermocontact S5 opens, K1 no longer excited. Contact K1 changes over (4-2). K3 no longer excited. K3 changes over (13-11), engine cuts out because fuel solenoid Y1 no longer excited and lamp H2 and H1 go on simultaneously. Take-over relay K2 is excited simultaneously with H1 and contact K2 closes (8-6).

Thermocontact S5 cools off and closes, K1 excited again and contact K1 changes over (4-1). However, lamp H1 remains on across line 9 and contact K2 (6-8).

A fault in the alternator part causes terminal D+ to go to 0V and K4 to be excited. Contact K4 changes over to (18-15), engine cuts out because fuel solenoid Y1 no longer excited and lamp H2 goes on simultaneously.

Generator function:

Turn switch S7 to position 1. The solenoid valve Y2 via the speed regulator SR controls the motor and allows it to reach maximum speed (the normal control system is switched off). Lamp H3 is activated and sockets X1.1, X1.2, X1.3 are under tension.

The generator can be switched off by turning switch S7 to position 0.

In the case of an insulation fault, the yellow LED on the insulation monitoring relay K6 of the system is activated. When the yellow LED of K6 is active, a reset can only occur by halting and restarting the assembly.

2.8.7 CIRCUIT DIAGRAM XAS 67 DdG, XAS 97 DdG
(GENERATOR DdG IT 230/400V, 12.5 kVA WITHOUT AUTOMATIC CONTROL SYSTEM)
 (Option; no hardhat)

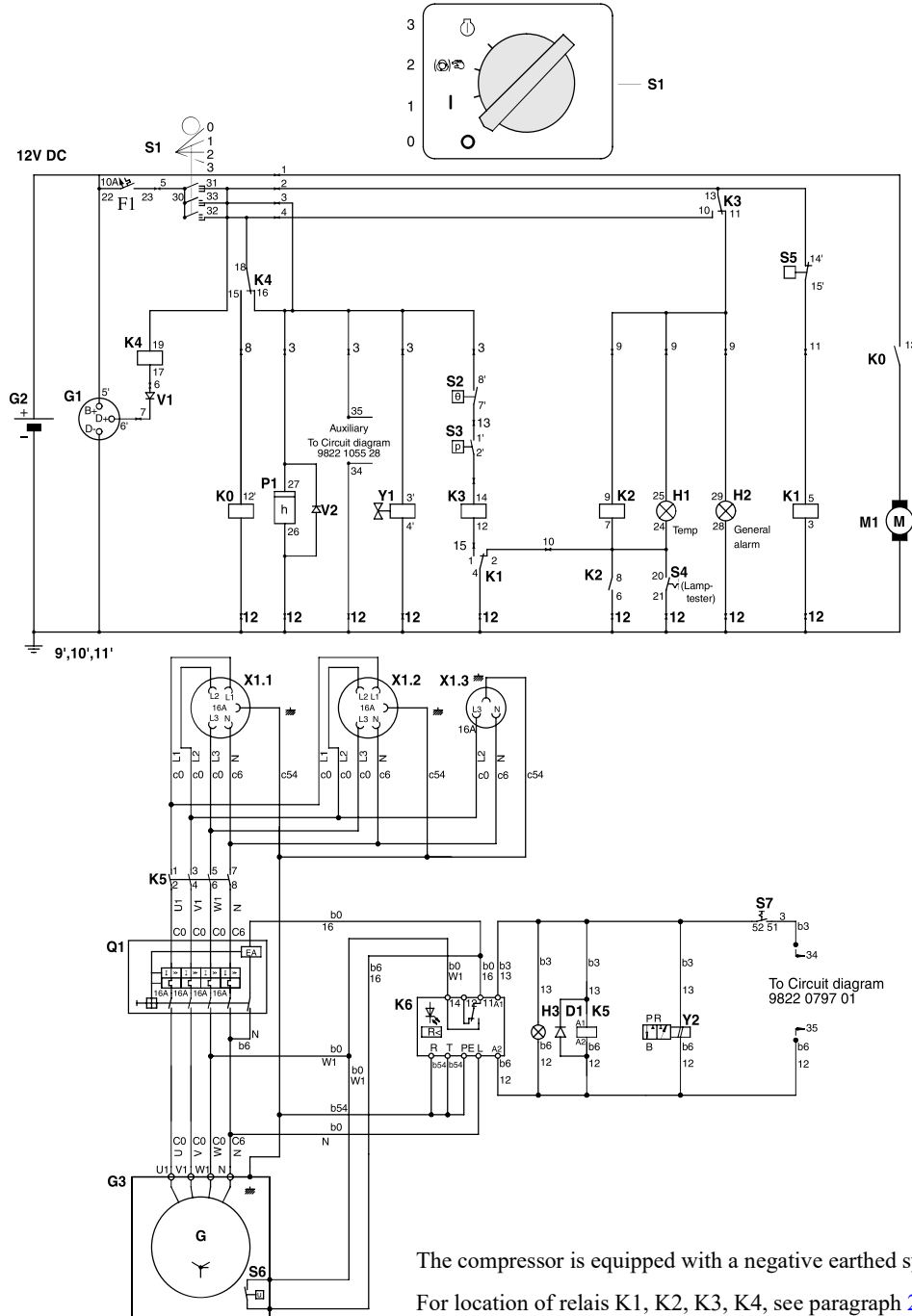

The compressor is equipped with a negative earthed system.
 For location of relays K1, K2, K3, K4, see paragraph 2.8.1

Fig. 2.11 Circuit diagram (No. 9822 0797 01 + No. 9822 1055 28)

D1	Diode	K2	Blocking Relay	S1	Contact Switch (Off-On-Override-start)	X1.1	Socket outlet
F1	Circuit Breaker (10 A)	K3	Override Start Relay	S2	Temperature Switch Engine	X1.2	Socket outlet
G1	Alternator	K4	Start Relay	S3	Oil Pressure Switch Engine	X1.3	Socket outlet
G2	Battery	K5	Contactora/4-pole	S4	Lampstest Switch	Y1	Fuel solenoid Valve (Generator action)
G3	Generator	K6	Insulation monitoring relay	S5	Temperature Switch Compressor	Y2	Solenoid valve (Generator action)
H1	Temperature Alarm Lamp	M1	Starter Motor	S6	Thermalcontact		
H2	General Alarm Lamp	P1	Hourmeter	S7	Switch (Generator-compressor)		
H3	Lamp (Power Control)	Q1	Main circuit breaker 4-pole + shunt tripcoil	V1	Diode		
K0	Starter Solenoid (part of M1)			V2	Diode		
K1	Shut-down Relay						

Operation of the electric circuit in detail

Start switch S1 position 1:

Line 2 on 12V contact K3 closed (13-11), lamp H2 is on. K4 excites contact K4 (18-15). Thermocontact element S5 normally closed, K1 excites contact K1 (1-4).

Use of lamp test:

Start switch S1 position 1 press lamp test S4, across K3 and line 9 lamp H1 and relay K2 are excited. After releasing lamp test button S4, lamp H1 remains on, S4 taken over by contact K2.

Start switch S1 position 2:

Line 3 on 12V (overwrite function) hourmeter P1 and fuel solenoid Y1 excited. Thermocontact engine S2 normally closed, oil pressure contact S3 open.

Start switch S1 position 3:

Start relay K0 is excited and starter motor is running, engine builds up oil pressure and oil pressure contact S3 closes. K3 excited and contact K3 changes over to (13-10). Relay K2 no longer excited, contact K2 opens, lamp H1 goes out. Alternator also commences supplying voltage and K4 is no longer excited and contact K4 changes over to (18-16). Lamp H2 goes out, one can release start switch S1 and it returns to position 1. Exciting the safety devices occurs no longer across line 3 but across line 2 to line 4 and this way to line 3.

Engine is running normally:

Oil pressure contact S3 opens, K3 no longer excited. K3 changes over (13-11), engine cuts out because fuel solenoid Y1 no longer excited and lamp H2 goes on simultaneously.

Thermocontact S2 opens, K3 no longer excited. K3 changes over (13-11), engine cuts out because fuel solenoid Y1 no longer excited and lamp H2 goes on simultaneously.

Thermocontact S5 opens, K1 no longer excited. Contact K1 changes over (4-2). K3 no longer excited. K3 changes over (13-11), engine cuts out because fuel solenoid Y1 no longer excited and lamp H2 and H1 go on simultaneously. Take-over relay K2 is excited simultaneously with H1 and contact K2 closes (8-6).

Thermocontact S5 cools off and closes, K1 excited again and contact K1 changes over (4-1). However, lamp H1 remains on across line 9 and contact K2 (6-8).

A fault in the alternator part causes terminal D+ to go to 0V and K4 to be excited. Contact K4 changes over to (18-15), engine cuts out because fuel solenoid Y1 no longer excited and lamp H2 goes on simultaneously.

Generator function:

Turn switch S7 to position 1. The solenoid valve Y2 via the speed regulator SR controls the motor and allows it to reach maximum speed (the normal control system is switched off). Lamp H3 is activated and sockets X1.1, X1.2, X1.3 are under tension.

The generator can be switched off by turning switch S7 to position 0.

In the case of an insulation fault, the yellow LED on the insulation monitoring relay K6 of the system is activated. When the yellow LED of K6 is active, a reset can only occur by halting and restarting the assembly.

2.8.8 CIRCUIT DIAGRAM XAS 67 DdG, XAS 97 DdG
(GENERATOR DdG IT 230/400V, 12.5 kVA WITH AUTOMATIC CONTROL SYSTEM)
 (Option; no hardhat)

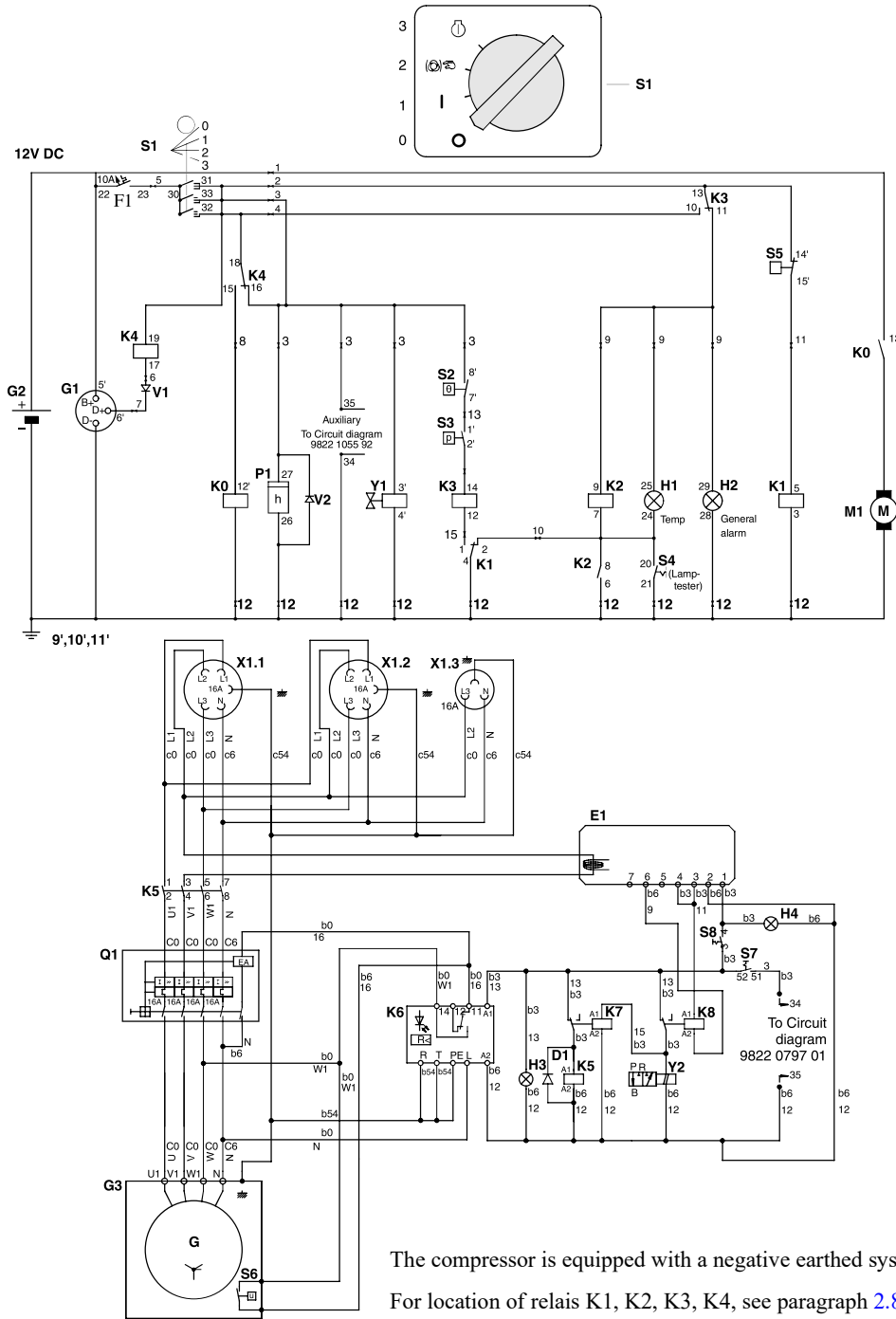

The compressor is equipped with a negative earthed system.
 For location of relays K1, K2, K3, K4, see paragraph 2.8.1

Fig. 2.12 Circuit diagram (No. 9822 0797 01 + No. 9822 1055 92)

D1 Diode	K2 Blocking Relay	S1 Contact Switch (Off-On-Override-start)	V1 Diode
E1 Ecologiser	K3 Override Start Relay	S2 Temperature Switch Engine	X1.1 Socket outlet
F1 Circuit Breaker (10 A)	K4 Start Relay	S3 Oil Pressure Switch Engine	X1.2 Socket outlet
G1 Alternator	K5 Contactor/4-pole	S4 Lamptest Switch	X1.3 Socket outlet
G2 Battery	K6 Insulation monitoring relay	S5 Temperature Switch	Y1 Fuel solenoid Valve
G3 Generator	K7 Time relays	S6 Thermalcontact	Y2 Solenoid valve (Generator action)
H1 Temperature Alarm Lamp	K8 Time relays	S7 Switch (Generator-compressor)	
H2 General Alarm Lamp	M1 Starter Motor	S8 Switch automatic control system	
H3 Lamp (Power Control)	P1 Hourmeter		
H4 Lamp automatic control system	Q1 Main circuit breaker 4-pole + shunt tripcoil		
K0 Starter Solenoid (part of M1)			
K1 Shut-down Relay			

Operation of the electric circuit in detail

Start switch S1 position 1:

Line 2 on 12V contact K3 closed (13-11), lamp H2 is on. K4 excites contact K4 (18-15). Thermocontact element S5 normally closed, K1 excites contact K1 (1-4).

Use of lamp test:

Start switch S1 position 1 press lamp test S4, across K3 and line 9 lamp H1 and relay K2 are excited. After releasing lamp test button S4, lamp H1 remains on, S4 taken over by contact K2.

Start switch S1 position 2:

Line 3 on 12V (overwrite function) hourmeter P1 and fuel solenoid Y1 excited. Thermocontact engine S2 normally closed, oil pressure contact S3 open.

Start switch S1 position 3:

Start relay K0 is excited and starter motor is running, engine builds up oil pressure and oil pressure contact S3 closes. K3 excited and contact K3 changes over to (13-10). Relay K2 no longer excited, contact K2 opens, lamp H1 goes out. Alternator also commences supplying voltage and K4 is no longer excited and contact K4 changes over to (18-16). Lamp H2 goes out, one can release start switch S1 and it returns to position 1. Exciting the safety devices occurs no longer across line 3 but across line 2 to line 4 and this way to line 3.

Engine is running normally:

Oil pressure contact S3 opens, K3 no longer excited. K3 changes over (13-11), engine cuts out because fuel solenoid Y1 no longer excited and lamp H2 goes on simultaneously.

Thermocontact S2 opens, K3 no longer excited. K3 changes over (13-11), engine cuts out because fuel solenoid Y1 no longer excited and lamp H2 goes on simultaneously.

Thermocontact S5 opens, K1 no longer excited. Contact K1 changes over (4-2). K3 no longer excited. K3 changes over (13-11), engine cuts out because fuel solenoid Y1 no longer excited and lamp H2 and H1 go on simultaneously. Take-over relay K2 is excited simultaneously with H1 and contact K2 closes (8-6).

Thermocontact S5 cools off and closes, K1 excited again and contact K1 changes over (4-1). However, lamp H1 remains on across line 9 and contact K2 (6-8).

A fault in the alternator part causes terminal D+ to go to 0V and K4 to be excited. Contact K4 changes over to (18-15), engine cuts out because fuel solenoid Y1 no longer excited and lamp H2 goes on simultaneously.

Generator function:

Turn switch S7 to position 1. The solenoid valve Y2 via the speed regulator SR controls the motor and allows it to reach maximum speed (the normal control system is switched off). Lamp H3 is activated. Time relay K7 disconnects the sockets from the generator during 4 sec, after which the sockets X1.1, X1.2, X1.3 are under tension.

The generator can be switched off by turning switch S7 to position 0.

If switch S7 is turned on, lamp H4 and ecologiser E1 are activated. E1 senses continuously the current to the sockets. If no current is sensed, time relay K8 is activated. This time relay deactivates the solenoid valve Y2 so that the speed regulator is again controlled by the normal compressor control system. When in this condition E1 senses current to the sockets, the solenoid valve Y2 is re-activated immediately by K8. Time relay K7 disconnects the sockets from the generator during 4 sec, after which the sockets X1.1, X1.2, X1.3 are under tension.

**2.8.9 CIRCUIT DIAGRAM XAS 67 DdG, XAS 97 DdG
(GENERATOR DdG IT 230V, 12.5 kVA)**
(Option; no hardhat)

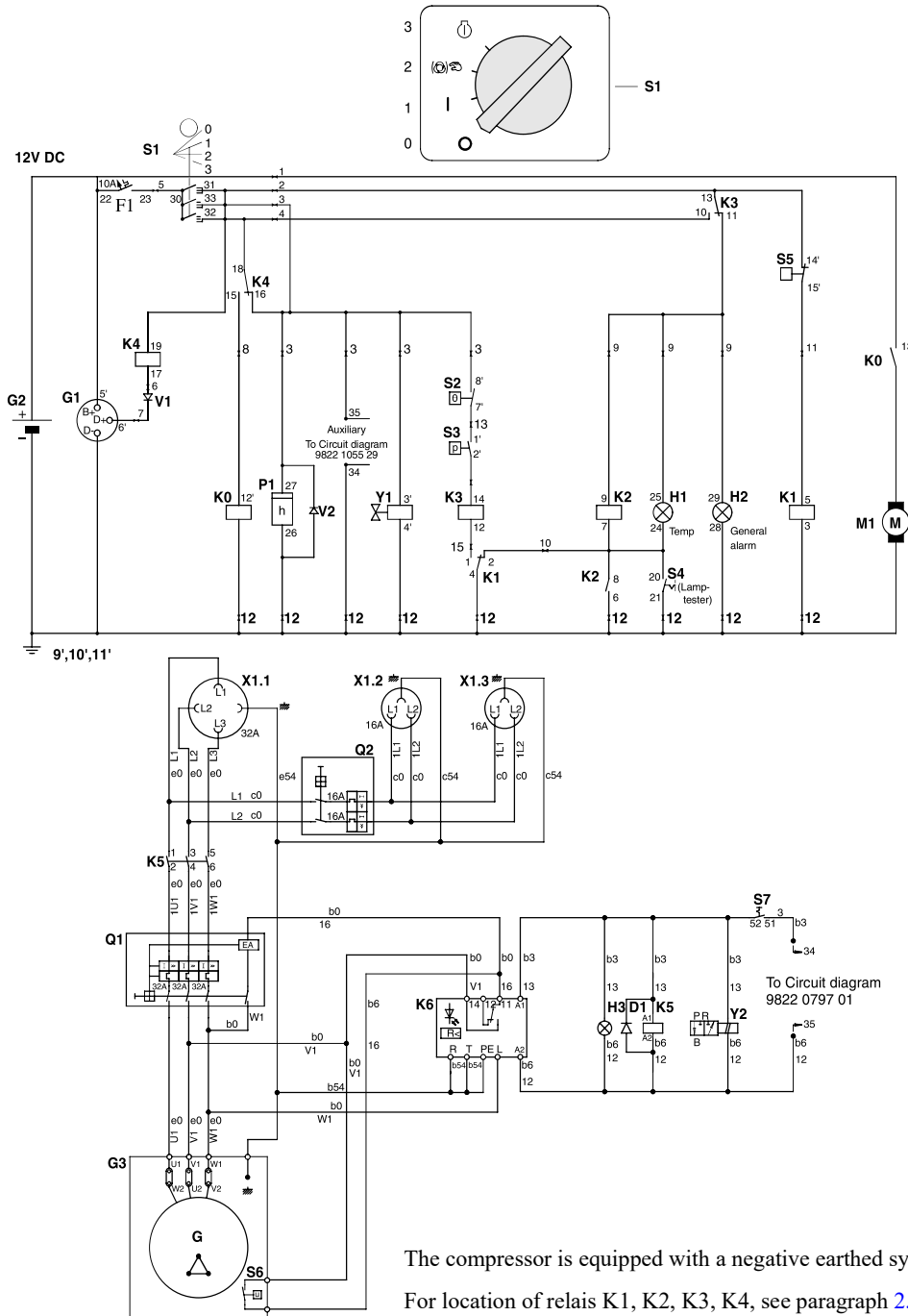

The compressor is equipped with a negative earthed system.
For location of relays K1, K2, K3, K4, see paragraph 2.8.1

Fig. 2.13 Circuit diagram (No. 9822 0797 01 + No. 9822 1055 29)

D1 Diode	K2 Blocking Relay	S1 Contact Switch (Off-On-Override-start)	V1 Diode
F1 Circuit Breaker (10 A)	K3 Override Start Relay	S2 Temperature Switch Engine	X1.1 Socket outlet
G1 Alternator	K4 Start Relay	S3 Oil Pressure Switch Engine	X1.2 Socket outlet
G2 Battery	K5 Contactor/4-pole	S4 Lamptest Switch	X1.3 Socket outlet
G3 Generator	K6 Insulation monitoring relay	S5 Temperature Switch Compressor	Y1 Fuel solenoid Valve
H1 Temperature Alarm Lamp	M1 Starter Motor	S6 Thermalcontact	Y2 Solenoid valve (Generator action)
H2 General Alarm Lamp	P1 Hourmeter	S7 Switch (Generator-compressor)	
H3 Lamp (Power Control)	Q1 Main circuit breaker 3-pole + shunt tripcoil		
K0 Starter Solenoid (part of M1)	Q2 Circuit breaker 2-pole		
K1 Shut-down Relay			

Operation of the electric circuit in detail

Start switch S1 position 1:

Line 2 on 12V contact K3 closed (13-11), lamp H2 is on. K4 excites contact K4 (18-15). Thermocontact element S5 normally closed, K1 excites contact K1 (1-4).

Use of lamp test:

Start switch S1 position 1 press lamp test S4, across K3 and line 9 lamp H1 and relay K2 are excited. After releasing lamp test button S4, lamp H1 remains on, S4 taken over by contact K2.

Start switch S1 position 2:

Line 3 on 12V (overwrite function) hourmeter P1 and fuel solenoid Y1 excited. Thermocontact engine S2 normally closed, oil pressure contact S3 open.

Start switch S1 position 3:

Start relay K0 is excited and starter motor is running, engine builds up oil pressure and oil pressure contact S3 closes. K3 excited and contact K3 changes over to (13-10). Relay K2 no longer excited, contact K2 opens, lamp H1 goes out. Alternator also commences supplying voltage and K4 is no longer excited and contact K4 changes over to (18-16). Lamp H2 goes out, one can release start switch S1 and it returns to position 1. Exciting the safety devices occurs no longer across line 3 but across line 2 to line 4 and this way to line 3.

Engine is running normally:

Oil pressure contact S3 opens, K3 no longer excited. K3 changes over (13-11), engine cuts out because fuel solenoid Y1 no longer excited and lamp H2 goes on simultaneously.

Thermocontact S2 opens, K3 no longer excited. K3 changes over (13-11), engine cuts out because fuel solenoid Y1 no longer excited and lamp H2 goes on simultaneously.

Thermocontact S5 opens, K1 no longer excited. Contact K1 changes over (4-2). K3 no longer excited. K3 changes over (13-11), engine cuts out because fuel solenoid Y1 no longer excited and lamp H2 and H1 go on simultaneously. Take-over relay K2 is excited simultaneously with H1 and contact K2 closes (8-6).

Thermocontact S5 cools off and closes, K1 excited again and contact K1 changes over (4-1). However, lamp H1 remains on across line 9 and contact K2 (6-8).

A fault in the alternator part causes terminal D+ to go to 0V and K4 to be excited. Contact K4 changes over to (18-15), engine cuts out because fuel solenoid Y1 no longer excited and lamp H2 goes on simultaneously.

Generator function:

Turn switch S7 to position 1. The solenoid valve Y2 via the speed regulator SR controls the motor and allows it to reach maximum speed (the normal control system is switched off). Lamp H3 is activated and sockets X1.1, X1.2, X1.3 are under tension.

The generator can be switched off by turning switch S7 to position 0.

In the case of an insulation fault, the yellow LED on the insulation monitoring relay K6 of the system is activated. When the yellow LED of K6 is active, a reset can only occur by halting and restarting the assembly.

2.8.10 CIRCUIT DIAGRAM COLD START
(ALL TYPES)

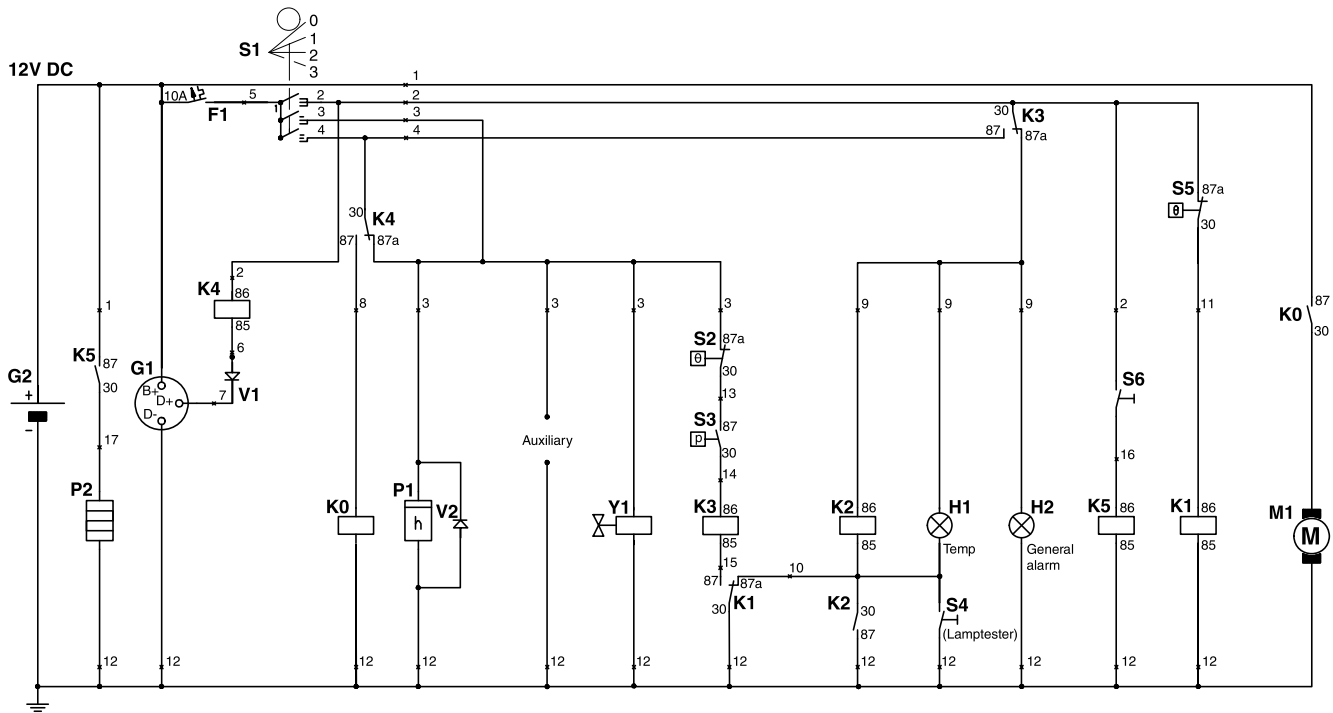

Fig. 2.14 Circuit diagram (No. 9822 0864 00)

F1	Circuit breaker (10 A)	S1	Contact switch (Off-On-Override-start)
G1	Alternator	S2	Temperature switch engine
G2	Battery	S3	Oil pressure switch engine
H1	Temperature alarm lamp	S4	Temperature lamp test switch
H2	General alarm lamp	S5	Temperature switch compressor
K0	Starter solenoid (part of M1)	S6	Push button glowplug
M1	Starter motor	Y1	Fuel solenoid valve
P1	Hourmeter	V1	Diode
P2	Glowplug	V2	Diode

2.8.11 CIRCUIT DIAGRAM REFINERY EQUIPMENT (ALL TYPES)

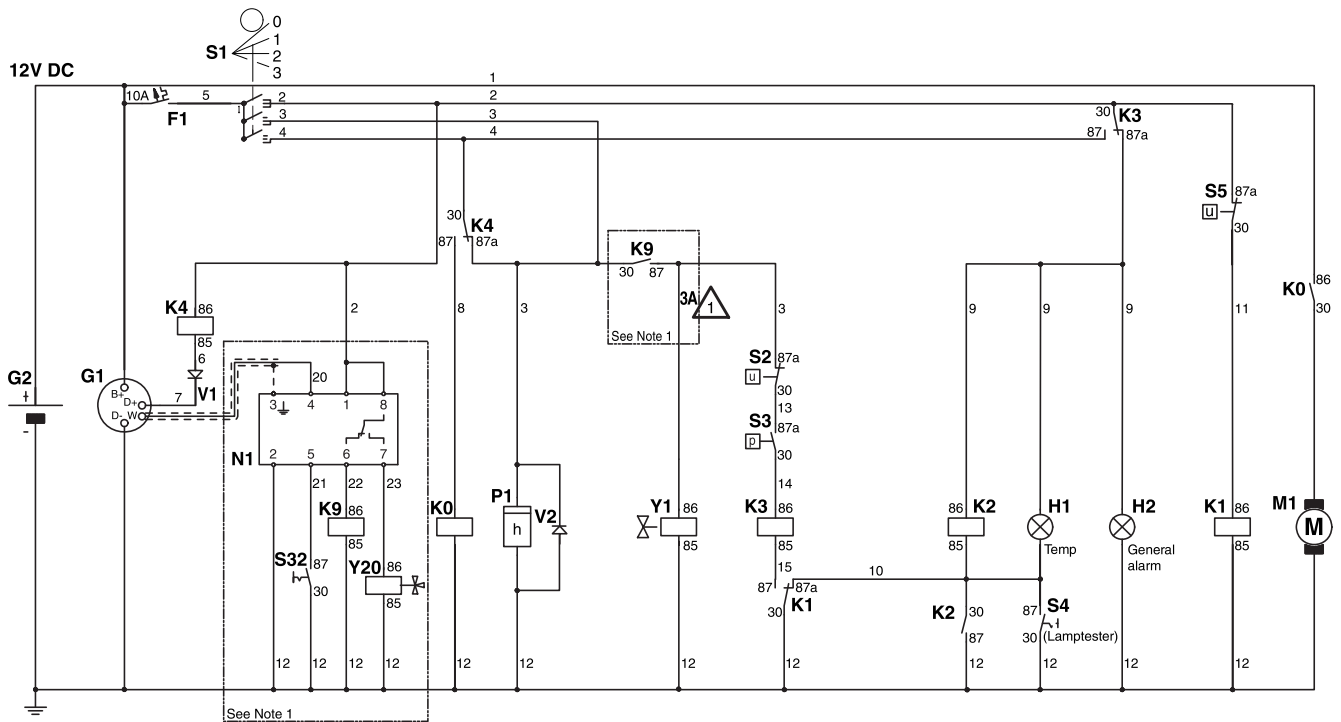

Fig. 2.15 Circuit diagram (No. 9822 0909 00)

F1	Circuit breaker (10 A)	S1	Contact switch (Off-On-Override-start)
G1	Alternator	S2	Temperature switch engine
G2	Battery	S3	Oil pressure switch engine
H1	Temperature alarm lamp	S4	Temperature lamptest switch
H2	General alarm lamp	S5	Temperature switch compressor
K0	Starter solenoid (part of M1)	S32	Test button overspeed
K9	Aux. relay safety circuit	Y1	Fuel solenoid valve
M1	Starter motor	Y20	Solenoid for overspeed protection valve
N1	Overspeed module	V1	Diode
P1	Hourmeter	V2	Diode

3. OPERATING INSTRUCTIONS

3.1 PARKING, TOWING AND LIFTING INSTRUCTIONS

Safety precautions.



The operator is expected to apply all relevant safety precautions, including those mentioned on the pages 7 - 11 of this book.

Attention:

- Before putting the compressor in to use, check the brake system as described in section 5.6.
- After the first 100 km travel:
 - Check and retighten the wheel nuts and towbar bolts to the specified torque. See section 3.1.3 and 8.1.
 - Check the brake adjustment. See section 5.6.

3.1.1 PARKING INSTRUCTIONS

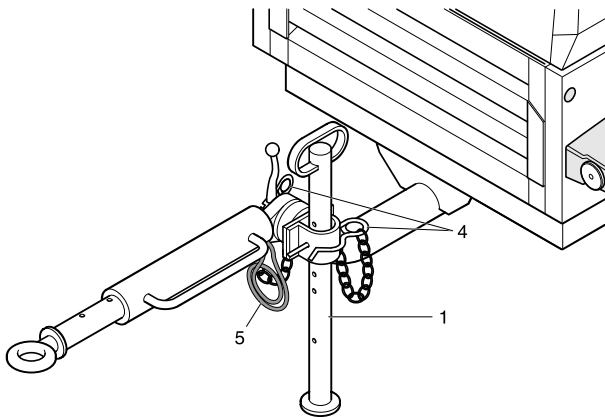

Fig. 3.1 Non-adjustable towbar with standard support leg without brakes

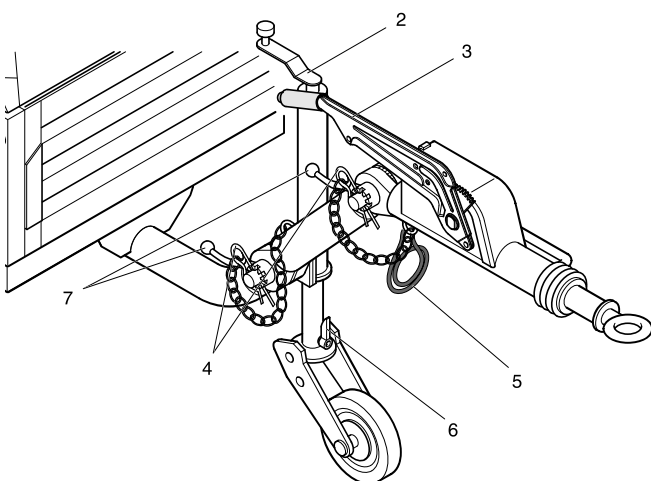

Fig. 3.2 Adjustable towbar with jockey wheel and brakes

When parking a compressor, secure support leg (1) or jockey wheel (2) to support the compressor in a level position. Be sure that the jockey wheel (2) is blocked by the blocking pin (6).

Apply parking brake by pulling parking brake handle (3) upwards. Place the compressor as level as possible; however, it can be operated temporarily in an out-of-level position not exceeding 15°. If the compressor is parked on sloping ground, immobilize the compressor by placing wheel chocks (available as option) in front of or behind the wheels. Locate the rear-end of the compressor upwind, (see Fig. 3.4), away from contaminated wind-streams and walls. Avoid recirculation of exhaust air from the engine. This causes overheating and engine power decrease.

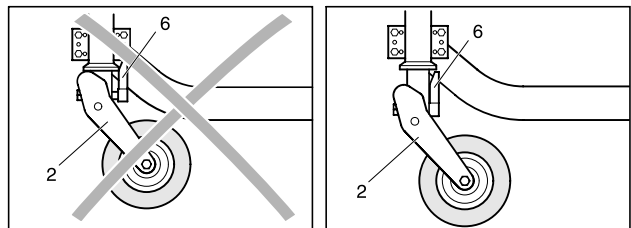

Fig. 3.3 Parking position of jockey wheel

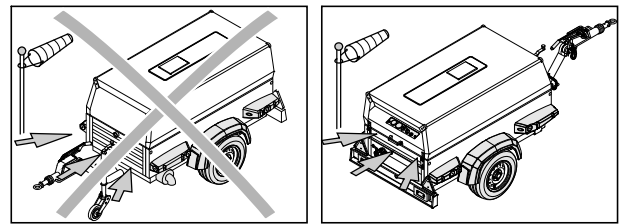

Fig. 3.4 Rear-end of compressor upwind

3.1.2 TOWING INSTRUCTIONS

! Before towing the compressor, ensure that the towing equipment of the vehicle matches the towing eye or ball connector, and ensure that the hood is closed and locked properly.

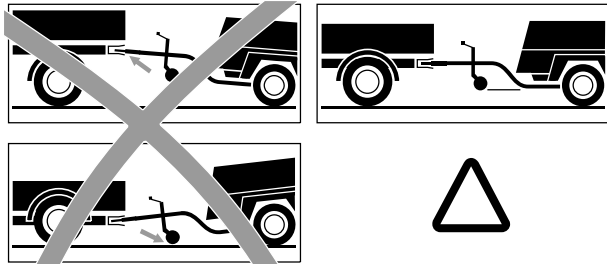

Fig. 3.5 Label on towbar, towing instructions

For both non-adjustable - and adjustable towbar, the towbar should be as level as possible and the compressor and towing eye end in a level position.

Push the hand brake lever (3) completely downwards and connect breakaway cable (5) to the vehicle. Secure jockey wheel (2) or support leg (1) in the highest possible position. The jockey wheel is prevented from turning.

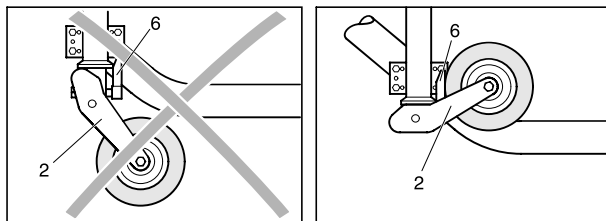

Fig. 3.6 Towing position of jockey wheel

3.1.3 HEIGHT ADJUSTMENT (WITH ADJUSTABLE TOWBAR)

! Before towing the compressor, make sure that the joints of the towbar are secured with maximum strength without damaging the towbar. Be sure that there is no clearance between the teeth of the joints.

For specific instruction see below!

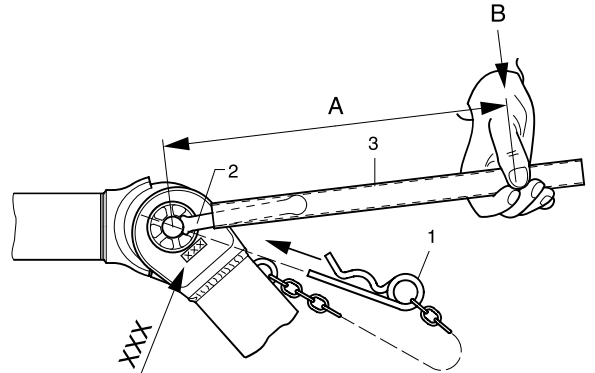

Fig. 3.7

Table

Type (XXX)	M_A [Nm]	"A" [mm]	"B" [N]
ZV 2000	250 - 300	600	420 - 500
ZV 2500	350 - 400	600	580 - 660

Fig. 3.8

- Remove spring pin (1).
- Release locking nut (2) with support tools (Extension tube 3).
- Adjust required height of the towbar.
- Tighten locking nut (2) by hand first.
- Secondly tighten locking nut (2) with a tightening torque corresponding to table (Fig. 3.8). With an extension tube (3) ("A" corresponding to table) and handforce ("B" corresponding to table) easy tightening is possible.
- Fix locking nut (2) with spring pin (1).

! **Attention:**

- Height adjustment should be undertaken on levelled ground and in coupled condition.
- When readjusting, make sure that the front point of the towbar is horizontal to the coupling point.
- Before starting a trip, make sure that the adjustment shaft is secure, so that the stability and safety is guaranteed while driving. If necessary tighten the locking nut (2) corresponding to table (Fig. 3.8).

3.1.4 LIFTING INSTRUCTIONS

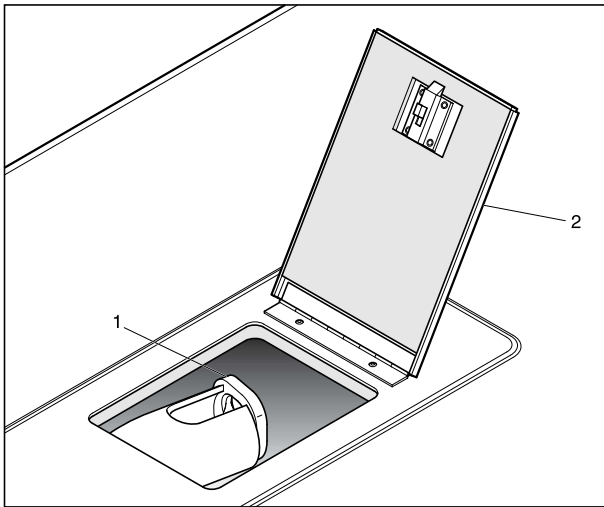

Fig. 3.9 Lifting eye

When lifting the compressor, the hoist has to be placed in such a way that the compressor, which must be placed level, will be lifted vertically. Keep lifting acceleration and retardation within safe limits.

Preferably use the lifting eye (1) after opening the small door (2).



Lifting acceleration and retardation must be kept within safe limits (max. 2g).

Helicopter lifting is not allowed.

Lifting is not allowed when the unit is running.

3.1.5 SPILLAGE-FREE INSTRUCTION

This compressor is fitted with a leak-proof undercarriage in order to protect the environment.

Any leaking fluid is collected in case of malfunctions. This fluid can be removed via outlets, normally secured by caps.

Tighten the caps firmly and check for leakages.

Please observe the locally applicable environmental regulations when removing the leaking liquid.

3.1.6 ANTI-FROST DEVICE (OPTION)

The anti-frost device consist of a manually operated by-pass valve (1) on the oil cooler to prevent freezing of the pneumatic tools at low ambient temperatures (partial by-pass).

As soon as the ambient temperature drops below 20° C it is recommended to open the valve and by-pass the oil cooler. The outlet air temperature will increase with 13-16° C and condensation in the air will be reduced.

It is also recommend to use the by-pass valve in case the compressor is used at partial load for a long time.

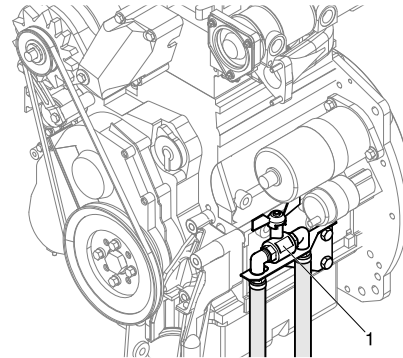

Fig. 3.10 Anti-frost device

3.2 STARTING/STOPPING

3.2.1 BEFORE STARTING

1. Before initial start-up, prepare battery for operation if not already done. See section 4.9.
2. With the compressor standing level, check the level of the engine oil. Add oil, if necessary, to the upper mark on dipstick. Consult the Engine Operation Manual for the type and viscosity grade of the engine oil.
3. Check the level of the compressor oil. The pointer of oil level gauge (Fig. 2.3, OLG) should register in the green range. Add oil if necessary. See section 4.3 for the oil to be used.



Before removing oil filler plug (Fig. 2.3, FP), ensure that the pressure is released by opening an air outlet valve.

4. Check that the fuel tank contains sufficient fuel. Top up, if necessary. Consult the Engine Operation Manual for the type of fuel.
5. In case of start up of the unit, after running out of fuel, pump up the fuel manually with the fuel hand pump before starting.
6. Drain any water and sediment from the fuel filter until clean fuel flows from the drain cock.
7. Drain leaking fluid from the frame.
8. Press vacuator valves (Fig. 2.3, VV) of the air filter to remove dust.
9. Check the air filter vacuum indicators (Fig. 2.3, VI). If the yellow piston reaches the red marked service range, replace the filter element. Reset the indicator by pushing the reset button.
10. Open air outlet valve to allow air flow to the atmosphere.

3.2.2 STARTING PROCEDURE (WITH COLD START; OPTION)

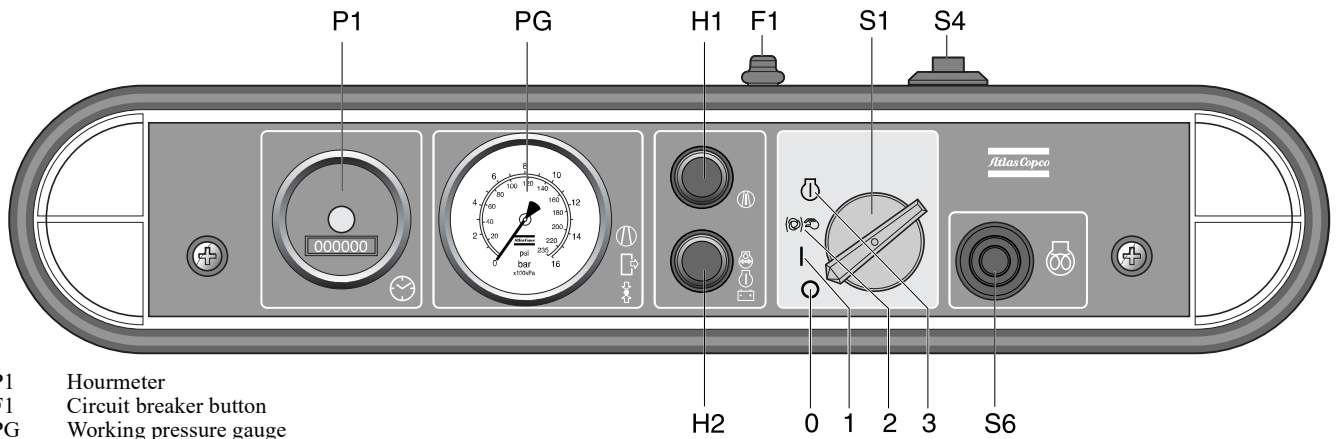

- P1 Hourmeter
- F1 Circuit breaker button
- PG Working pressure gauge
- H1 Temperature alarm lamp (red)
- H2 General alarm lamp (red)
- S1 Start switch
- S4 Lamp test button
- S6 Cold start button

Fig. 3.11 Control panel (with cold start; option)

The control panel indicates receiver pressure (PG) and accumulated operating hours (P1).

Before starting open the air outlet valve(s) (Fig. 2.3, AOV) and push circuit breaker button (F1) once (open hood first). To preheat if necessary, first push the cold start button S6 for a short period.

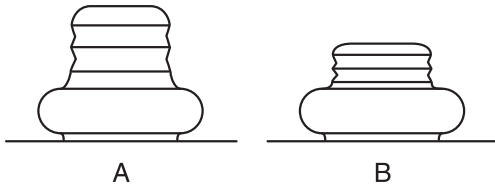

Fig. 3.12 Positions of circuit breaker button

Circuit breaker button should now be in position B.

The circuit breaker button is a protection against unintended starting of the compressor.

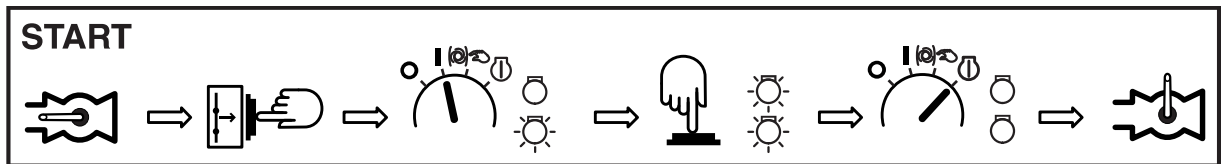
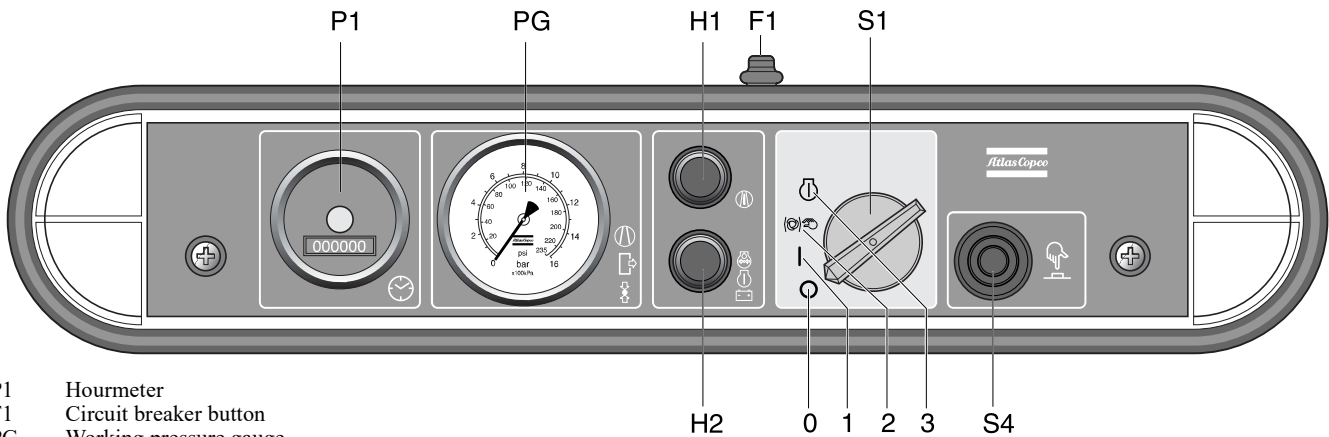

Fig. 3.13 Starting procedure

1. To start, turn start switch S1 clockwise to position 1, lamp H2 (general alarm lamp) will go on.
 2. Check correct operation of alarm lamps H1 and H2 by pushing lamp test button S4. Both alarm lamps (red) should go on.
 3. Turn start switch S1 further clockwise into position 3. The starter motor will set the engine in motion. The maximum allowed starter time, where the starter motor is running continuously is 20 seconds. If the engine does not catch, a new attempt can be made after 30 seconds waiting.
 4. The start switch automatically springs back to position 1. Lamp H1 only will go on when the compressor outlet temperature is too high.
 5. Close the air outlet valve(s) (Fig. 2.3, AOV).
- The temperature alarm lamp H1 and the general alarm lamp H2 will go out as soon as the engine has been started.

3.2.3 STARTING PROCEDURE (WITHOUT COLD START)



- P1 Hourmeter
- F1 Circuit breaker button
- PG Working pressure gauge
- H1 Temperature alarm lamp (red)
- H2 General alarm lamp (red)
- S1 Start switch
- S4 Lamp test button

Fig. 3.14 Control panel (without cold start)

 **The control panel indicates receiver pressure (PG) and accumulated operating hours (P1).**

Before starting open the air outlet valve(s) (Fig. 2.3, AOV) and push circuit breaker button (F1) once (open hood first).

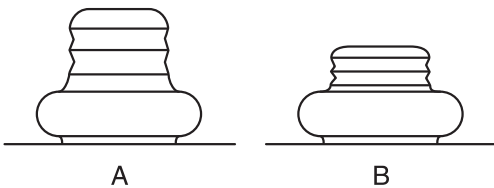



Fig. 3.15 Positions of circuit breaker button

Circuit breaker button should now be in position B.

 **The circuit breaker button is a protection against unintended starting of the compressor.**

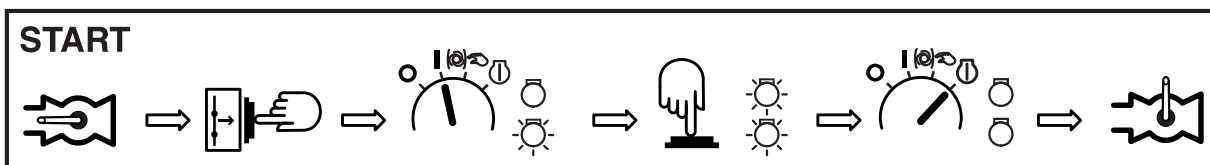

Fig. 3.16 Starting procedure

1. To start, turn start switch S1 clockwise to position 1, lamp H2 (general alarm lamp) will go on.
2. Check correct operation of alarm lamps H1 and H2 by pushing lamp test button S4. Both alarm lamps (red) should go on.
3. Turn start switch S1 further clockwise into position 3. The starter motor will set the engine in motion. The maximum allowed starter time, where the starter motor is running continuously is 20 seconds. If the engine does not catch, a new attempt can be made after 30 seconds waiting. The temperature alarm lamp (H1) and the general alarm lamp H2 will go out as soon as the engine has been started.
4. The start switch automatically springs back to position 1. Lamp H1 only will go on when the compressor outlet temperature is too high.
5. Close the air outlet valve(s) (Fig. 2.3, AOV).

3.2.4 DURING OPERATION



When the engine is running, the air outlet valves (ball valves) must always be put in a fully opened or fully closed position.



The hood must be closed during operation and may be opened for short periods only.

Regularly carry out following checks:

1. That the regulating valve (RV) is correctly adjusted, i.e. starts decreasing the engine speed when reaching the preset working pressure in the receiver.
2. Check the air filter vacuum indicator (VI - Fig. 2.3). If the yellow piston reaches the red marked service range, replace the filter element. Reset the indicator by pushing the reset button.
3. On compressors with aftercooler, check that the automatic drain of the water separator is operative without air leakage.

3.2.5 STOPPING PROCEDURE

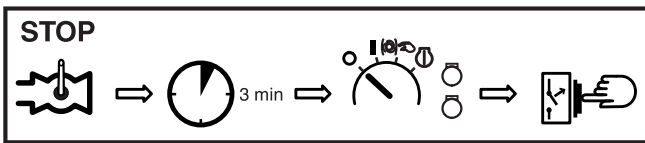

Fig. 3.17 Stopping procedure

1. Close the air outlet valves (Fig. 2.3, AOV).
2. Run unloaded for 3 minutes.
3. Turn the start switch S1 counterclockwise (CCW) to position 0.
4. Push the circuit breaker button (F1) once (open hood first).

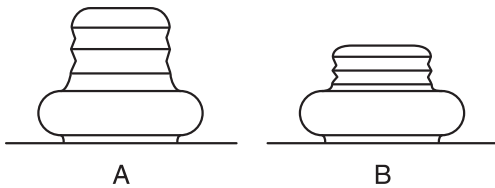

Fig. 3.18 Positions of circuit breaker button

Circuit breaker button should now be in position A.

3.2.6 FAULT SITUATIONS AND PROTECTIVE DEVICES:

- A fault which occurs with the engine, either: oil pressure (too low), oil temperature (too high) or alternator voltage (too low) will always and immediately cause the engine to cut out and the control lamp H2 will light up. By doing some simple checks, it can be determined what it was that caused the engine to fail: low oil level, clogged-up cooler, slack alternator belt tension or broken belt.
- When the outlet temperature of the element becomes too high, a thermocontact will also switch off the group immediately. Both control lamps H1 and H2 will light up. Both control lamps will remain on until the group has been restarted (start switch to position 3) or the contact is turned off (start switch to position 0); also when, due to cooling off, the thermocontact has closed again (= memory function).

Machine Verhuur Oosterwolde

3.3 FUNCTION OF GENERATOR (OPTION)

3.3.1 FUNCTION OF GENERATOR DdG 110V WITHOUT AUTOMATIC CONTROL SYSTEM - FUNCTIONAL DESCRIPTION

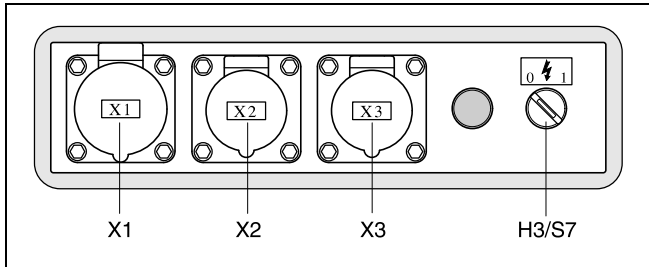

Fig. 3.19 Control panel (generator)

- H3 Lamp (green, power ON)
- S7 Switch (generator - compressor)
- X1 Socket 110 V/ 32 A
- X2 Socket 110 V/ 16 A
- X3 Socket 110 V/ 16 A

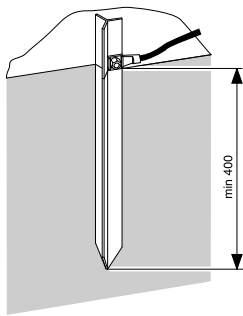

Fig. 3.20 Earth pin



Before switching on the generator, always place the earth pin in position. Check the cable connection between earth pin and unit.

Start the unit in accordance with the normal procedure (see [section 3.2](#)). Let the motor warm up until it reaches operational temperature. Turn the green switch S7 to position 1. The normal control system is switched off and the motor speed increases to reach the maximum.

The green lamp H3 in the switch S7 is activated, showing that sockets X1, X2 and X3 are under tension.

The generator can be switched off by turning the green switch S7 to position 0.

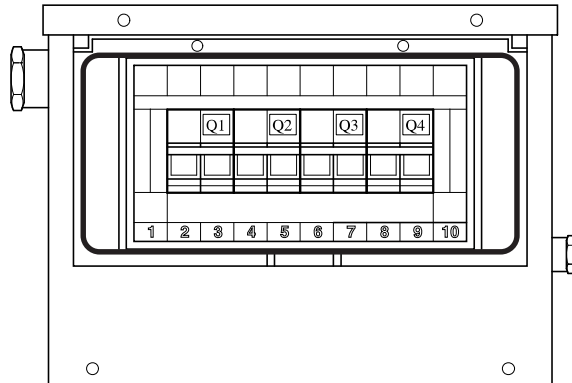

Fig. 3.21 Generator control box

- Q1 Main circuit breaker 2-pole
- Q2 Circuit breaker 2-pole
- Q3 Circuit breaker 2-pole
- Q4 Circuit breaker 2-pole



Before connecting an electrical device, always check the data listed on the rating plate.

Fault situations and protective devices:

- When switching on the generator by means of the switch S7, there is no voltage available at the sockets. Open the hood and check if the circuit breakers are down. If so, put them up (switch them on). If the circuit breakers are up, it can be indicative of a serious electrical fault.
- When the electrical device is connected, the circuit breakers switch always off. This indicates a fault in the electrical device.

3.3.2 FUNCTION OF GENERATOR DDG 110V WITH AUTOMATIC CONTROL SYSTEM (OPTION) - FUNCTIONAL DESCRIPTION

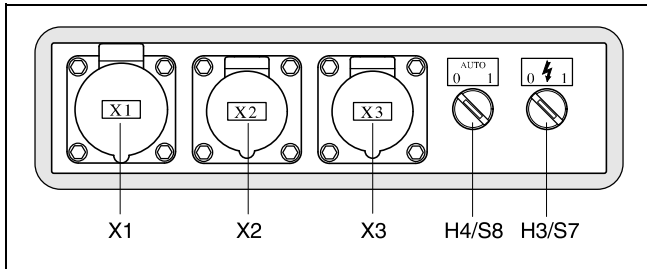

Fig. 3.22 Control panel (generator)

- H3 Lamp (green, power ON)
- S7 Switch (generator - compressor)
- H4 Lamp automatic control system
- S8 Switch automatic control system
- X1 Socket 110 V/ 32 A
- X2 Socket 110 V/ 16 A
- X3 Socket 110 V/ 16 A

As soon as the generator is switched on, the automatic control system will continuously check for electric load in order to rev up the engine from idle to nominal speed only when needed. This saves fuel and reduces emissions.

What is more, with the current continuously monitored, a consumer having just been switched on is temporarily disconnected from the generator to be re-connected as soon as the engine reaches nominal speed. This is a safety mechanism to protect generator and engine below nominal speed.

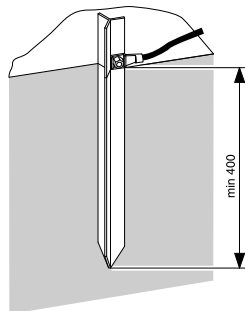

Fig. 3.23 Earth pin



Before switching on the generator, always place the earth pin in position. Check the cable connection between earth pin and unit.

Operation with automatic control switch S8 "OFF"

- Switch generator main switch S7 "ON".
- Generator is disconnected from socket.
- Engine reaches nominal speed.
- Generator is re-connected after 4 secs.
- Power is now available until the generator main switch S7 is turned "OFF".

Operation with automatic control switch S8 "ON"

- Switch generator main switch S7 "ON".
- Generator is disconnected from socket.
- Engine reaches nominal speed.
- Generator is re-connected after 4 secs.
- If a consumer is connected, the engine goes on for 60 secs. before falling back to idle speed.
- Generator is in standby. As soon as any consumer is switched on, the routine is repeated from step 2.

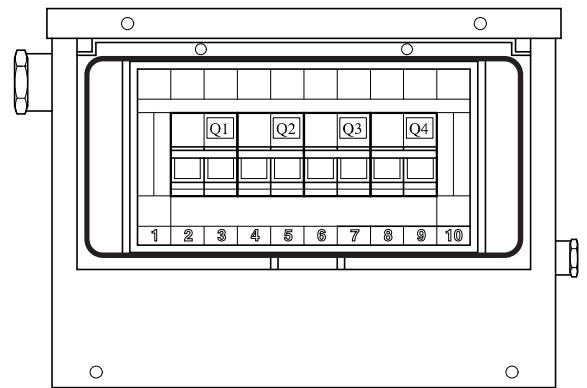

Fig. 3.24 Generator control box

- Q1 Main circuit breaker 2-pole
- Q2 Circuit breaker 2-pole
- Q3 Circuit breaker 2-pole
- Q4 Circuit breaker 2-pole



Before connecting an electrical device, always check the data listed on the rating plate.

Fault situations and protective devices:

- When switching on the generator by means of the switch S7, there is no voltage available at the sockets. Open the hood and check if the circuit breakers are down. If so, put them up (switch them on). If the circuit breakers are up, it can be indicative of a serious electrical fault.
- When the electrical device is connected, the circuit breakers switch always off. This indicates a fault in the electrical device.

3.3.3 FUNCTION OF GENERATOR DdG 230/400V AND 230V - 3PH WITHOUT AUTOMATIC CONTROL SYSTEM - FUNCTIONAL DESCRIPTION

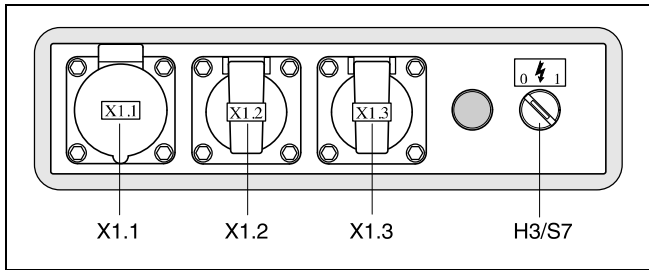

Fig. 3.25 Control panel (generator)

Generator DdG 230/400V:

- S7 Switch
- H3 Lamp (green)
- X1.1 Socket 400 V/ 16A
- X1.2 Socket 230 V/ 16 A*
- X1.3 Socket 230 V/ 16 A

Generator DdG 230V:

- S7 Switch
- H3 Lamp (green)
- X1.1 Socket 230 V/ 16A**
- X1.2 Socket 230 V/ 16 A
- X1.3 Socket 230 V/ 16 A

* For 6 kVA.
For 12.5 kVA: Socket 400V / 16A.

** For 6 kVA.
For 12.5 kVA: socket 230V / 32A.

Start the unit in accordance with the normal procedure (see section 3.2). Let the motor warm up until it reaches operational temperature. Turn the green switch S7 to position 1. The normal control system is switched off and the engine speed increases to reach the maximum.

The green lamp H3 in the switch S7 is activated, showing that sockets X1.1, X1.2 and X1.3 are under tension.

The generator can be switched off by turning the green switch S7 to position 0.

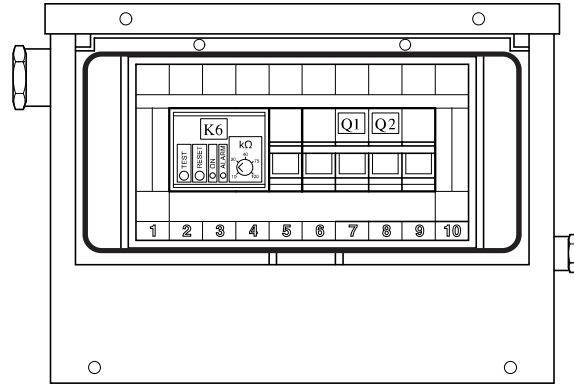

Fig. 3.26 Generator control box

Generator DdG 230/400V:

- Q1 Main circuit breaker 4-pole + shunt trip coil
- K6 Insulation monitoring relay

Generator DdG 230V:

- Q1 Main circuit breaker 3-pole + shunt trip coil
- Q2 Circuit breaker 2-pole (for 12.5 kVA only)
- K6 Insulation monitoring relay



Before connecting an electrical device, always check the data listed on the rating plate.

Fault situations and protective devices:

- When switching on the generator by means of the switch S7, there is no voltage available at the sockets. Open the hood and check if the circuit breakers are up. If the circuit breakers are down, put them up (switch them on). Circuit breakers in the up position can be indicative of a serious electrical fault.
- When the electrical device is connected, the circuit breakers always switch off. This indicates a fault in the electrical device.
- When the yellow LED on the insulation monitoring relay K6 is activated, it means that a serious insulation fault has occurred. Reset by first switching off the engine, then restart it.
- The insulation monitoring relay K6 must be adjusted to 10 kΩ. This adjustment may not be changed.
- The thermal contact S6 closes when the temperature in the generator becomes too high.

3.3.4 FUNCTION OF GENERATOR DdG 230/400V AND 230V - 3PH WITH AUTOMATIC CONTROL SYSTEM (OPTION) - FUNCTIONAL DESCRIPTION

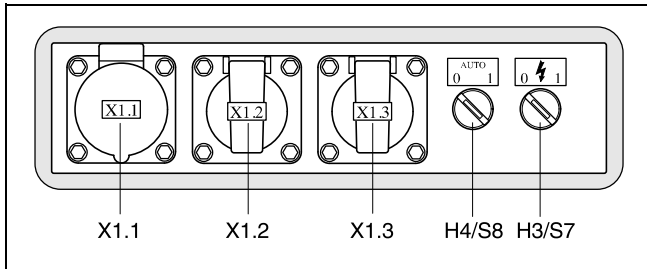

Fig. 3.27 Control panel (generator)

Generator DdG 230/400V:

- H3 Lamp (green, power ON)
- S7 Switch (generator - compressor)
- H4 Lamp automatic control system
- S8 Switch automatic control system
- X1.1 Socket 400 V/ 16A
- X1.2 Socket 230 V/ 16 A*
- X1.3 Socket 230 V/ 16 A

Generator DdG 230V:

- H3 Lamp (green, power ON)
- S7 Switch (generator - compressor)
- H4 Lamp automatic control system
- S8 Switch automatic control system
- X1.1 Socket 230 V/ 16A**
- X1.2 Socket 230 V/ 16 A
- X1.3 Socket 230 V/ 16 A

* For 6 kVA.
For 12.5 kVA: Socket 400V / 16A.

** For 6 kVA.
For 12.5 kVA: socket 230V / 32A.

As soon as the generator is switched on, the automatic control system will continuously check for electric load in order to rev up the engine from idle to nominal speed only when needed. This saves fuel and reduces emissions.

What is more, with the current continuously monitored, a consumer having just been switched on is temporary disconnected from the generator to be re-connected as soon as the engine reaches nominal speed. This is a safety mechanism to protect generator and engine below nominal speed.

Operation with automatic control switch S8 "OFF"

- Switch generator main switch S7 "ON".
- Generator is disconnected from socket.
- Engine reaches nominal speed.
- Generator is re-connected after 4 secs.
- Power is now available until the generator main switch S7 is turned "OFF".

Operation with automatic control switch S8 "ON"

- Switch generator main switch S7 "ON".
- Generator is disconnected from socket.
- Engine reaches nominal speed.
- Generator is re-connected after 4 secs.
- If a consumer is connected, the engine goes on for 60 secs. before falling back to idle speed.
- Generator is in standby. As soon as any consumer is switched on, the routine is repeated from step 2.

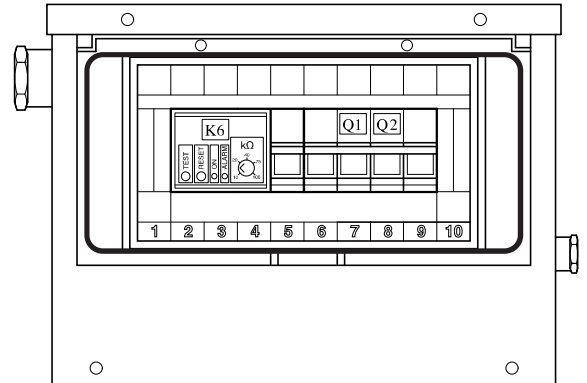

Fig. 3.28 Generator control box

Generator DdG 230/400V:

- Q1 Main circuit breaker 4-pole + shunt trip coil
- K6 Insulation monitoring relay

Generator DdG 230V:

- Q1 Main circuit breaker 3-pole + shunt trip coil
- Q2 Circuit breaker 2-pole (for 12.5 kVA only)
- K6 Insulation monitoring relay



Before connecting an electrical device, always check the data listed on the rating plate.

Fault situations and protective devices:

- When switching on the generator by means of the switch S7, there is no voltage available at the sockets. Open the hood and check if the circuit breakers are up. If the circuit breakers are down, put them up (switch them on). Circuit breakers in the up position can be indicative of a serious electrical fault.
- When the electrical device is connected, the circuit breakers always switch off. This indicates a fault in the electrical device.
- When the yellow LED on the insulation monitoring relay K6 is activated, it means that a serious insulation fault has occurred. Reset by first switching off the engine, then restart it.
- The insulation monitoring relay K6 must be adjusted to 10 kΩ. This adjustment may not be changed.
- The thermal contact S6 closes when the temperature in the generator becomes too high.

4. MAINTENANCE

4.1 USE OF SERVICE PAKS

Service Paks include all genuine parts needed for normal maintenance of both compressor and engine.

Service Paks minimize downtime and keep your maintenance budget low.

Order Service Paks at your local Atlas Copco dealer.

4.2 PREVENTIVE MAINTENANCE SCHEDULE FOR THE COMPRESSOR

The schedule contains a summary of the maintenance instructions. Read the respective section before taking maintenance measures.

When servicing, replace all disengaged packings, e.g. gaskets, O-rings, washers.

For engine maintenance refer to Engine Operation Manual.

The maintenance schedule has to be seen as a guideline for units operating in a dusty environment typical to compressor applications. Maintenance schedule can be adapted depending on application, environment and quality of maintenance.

Maintenance schedule	Daily	Initially <i>50 hours after initial start-up</i>	Yearly <i>or every 500 hours</i>
----------------------	-------	---	-------------------------------------

Service pak XAS 67 Dd, XATS 67 Dd, XAS 77 Dd		–	2912 4392 06
Service pak XAS 97 Dd		–	2912 4393 06
Engine oil level	Check		
Compressor oil level	Check		
Fuel level	Check/Fill		
Air filter vacuator valves	Empty		
Fuel filter water drain	Drain		
Air intake vacuum indicators	Check		
For spillage free, drain water out of frame	Check/Drain		
General conditions (leaks, damaged parts, loose bolts, trouble in previous operation)	Check		
During operation (meters and lamps, noise, colour exhaust fumes)	Check		
Electrolyte level and terminals of battery		Check	Check
Tyre pressure		Check	Check
Leaks in air-, oil- or fuel system		Check	Check
Oil coolers			Clean
Engine minimum and maximum speeds		Check	Check
Torque of wheel nuts		Check	Check
Brake system (if installed)		Check/Adjust	Check/Adjust
Safety valve			Test
Door hinges			Grease
Coupling head and all its moving parts / shaft			Grease
Joints of height adjustment adjustable towbar		Check	Grease
Shutdown switches			Check
Pressure drop over separator element (2)			Replace
Fan V-belt (3)			Adjust
Fuel tank			Clean
Compressor oil			Change
Compressor oil filter			Replace
Air filter element (1)			Replace
Safety cartridges (1) (option)			Replace
Engine oil (3) (4) (5)			Change
Engine oil filter (3)			Replace
Fuel filter (3) (6)			Replace
Engine inlet and outlet valves (3)			Adjust (7)
PD / QD filter (option)			Replace

- (1) More frequently when operating in a dusty environment.
- (2) Replace the element when the pressure drop exceeds 0.8 bar.
- (3) Refer to the Deutz operation manual.
- (4) 500 hours only valid when using PAROIL SAE 15 W 40.

- (5) Also drain engine oil from engine oil cooler (see Fig. 2.2 DP_{EC} = Drain plug engine oil cooler).
- (6) In case of poor fuel quality, replace fuel filter more frequently.
- (7) The valves need to be adjusted for the first time before 500 running hours.



Keep the bolts of the housing, the lifting eye, the towbar and the axle securely tightened. Refer to section 8 'Technical specifications' and section 3.1.3 for the torque values.

4.3 LUBRICATION OILS

High-quality, mineral, hydraulic or synthesized hydrocarbon oil with rust and oxidation inhibitors and anti-foam and anti-wear properties is recommended. The viscosity grade should correspond to the ambient temperature and ISO 3448, as follows:

Type of lubricant	Compressor**	Engine*
between 30°C and 40°C	PAROIL S	PAR OIL 15W40
between 30°C and -5°C	PAROIL M PAROIL S	PAR OIL 15W40
between -5°C and -20°C	PAROIL S	PAR OIL 5W30

PAROIL from Atlas Copco is the ONLY oil tested and approved for use in all engines built into Atlas Copco compressors and generators. Extensive laboratory and field endurance tests on Atlas Copco equipment have proven PAROIL to match all lubrication demands in varied conditions. It meets stringent quality control specifications to ensure your equipment will run smoothly and reliably. The quality lubricant additives in PAROIL allow for extended oil change intervals without any loss in performance or longevity.

PAROIL provides wear protection under extreme conditions. Powerful oxidation resistance, high chemical stability and rust-inhibiting additives help reduce corrosion, even within engines left idle for extended periods.

PAROIL contains high quality anti-oxidants to control deposits, sludge and contaminants that tend to build up under very high temperatures.

PAROIL's detergent additives keep sludge forming particles in a fine suspension instead of allowing them to clog your filter and accumulate in the valve/rocker cover area.

PAROIL releases excess heat efficiently, whilst maintaining excellent bore-polish protection to limit oil consumption.

PAROIL has an excellent Total Base Number (TBN) retention and more alkalinity to control acid formation.

PAROIL prevents Soot build-up

PAROIL is optimized for the latest low emission EURO -3 & -2, EPA TIER II & III engines running on low sulphur diesel for lower oil and fuel consumption.

PAROIL 5W30 is a Synthetic ultra high performance diesel engine oil with a high viscosity- index. Atlas Copco PAROIL 5W30 is designed to provide excellent lubrication from start-up in temperatures as low as -25°C.

PAROIL 15W40 is a mineral based high performance diesel engine oil with a high viscosity- index. Atlas Copco PAROIL 15W40 is designed to provide a high level of performance and protection in 'standard' ambient conditions as from -15°C.

*
If you want to use another brand of oil, consult the engine instruction manual.

**
It is strongly recommended to use Atlas Copco branded lubrication oils for the compressor. If you want to use another brands of oil, consult Atlas Copco.

Mineral compressor oil **PAROIL M:**

- 5 liter can: order number **1615 5947 00**
- 20 liter can: order number **1615 5948 00**
- 210 liter barrel: order number **1615 5949 00**

Synthetic compressor oil **PAROIL S:**

- 5 liter can: order number **1615 5950 01**
- 20 liter can: order number **1615 5951 01**
- 210 liter barrel: order number **1615 5952 01**

Mineral engine oil **PAROIL 15W40:**

- 5 liter can: order number **1615 5953 00**
- 20 liter can: order number **1615 5954 00**
- 210 liter barrel: order number **1615 5955 00**

Synthetic engine oil **PAROIL 5W30:**

- 5 liter can: order number **1604 6060 00**
- 20 liter can: order number **1604 6059 00**



Never mix synthetic with mineral oil.

Remark:

When changing from mineral to synthetic oil (or the other way around), you will need to do an extra rinse:

After doing the complete change procedure to synthetic oil, run the unit for a few minutes to allow good and complete circulation of the synthetic oil. Then drain the synthetic oil again and fill again with new synthetic oil. To set correct oil levels, proceed as in normal instruction.

4.4 OIL LEVEL CHECK



Never mix oils of different brands or types.

Use only non-toxic oils where there is a risk of inhaling delivered air.

4.4.1 CHECK ENGINE OIL LEVEL

Consult also the Engine Operation Manual for the oil specifications, viscosity recommendations and oil change intervals.

See schedule 4.2.

Check engine oil level according to the instructions in the Engine Operation Manual and top up with oil if necessary.

4.4.2 CHECK COMPRESSOR OIL LEVEL

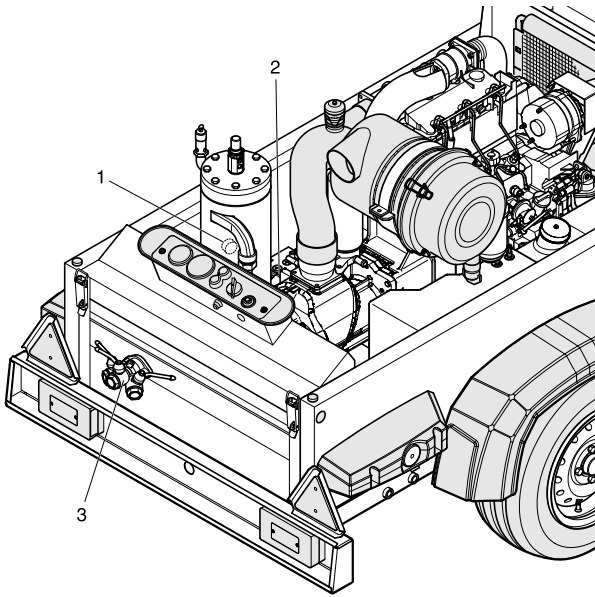

Fig. 4.1 Check compressor oil level

With the unit standing level, check the level of the compressor oil. The pointer of the oil level gauge (1) must register in the upper extremity of the green range. Add oil if necessary.



Before removing the oil filler plug (2), ensure that the pressure is released by opening an air outlet valve (3).

4.5 OIL AND OIL FILTER CHANGE

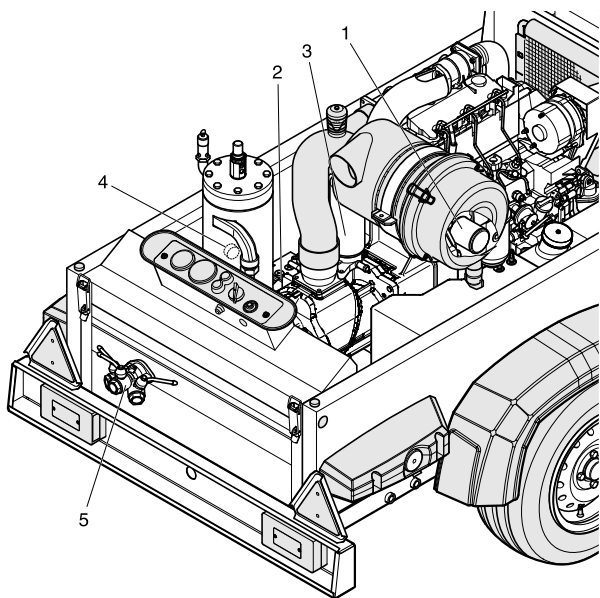

Fig. 4.2 Oil filters

4.5.1 ENGINE OIL AND OIL FILTER CHANGE

See section 4.2.

4.5.2 COMPRESSOR OIL AND OIL FILTER CHANGE

The quality and the temperature of the oil determine the oil change interval.

The prescribed interval (see section 4.2) is based on an oil temperature of up to 100 °C and normal operating conditions.

When operating in high ambient temperatures, in very dusty or high humidity conditions, it is recommended to change the oil more frequently.



In this case, contact Atlas Copco.

1. Run the compressor until warm. Close the outlet valve(s) (5) and stop the compressor. Wait until the pressure is released through the automatic blow-down valve. Unscrew the oil filler plug (2) one turn. This uncovers a vent hole, which permits any pressure in the system to escape.
2. Drain the oil by removing all relevant drain plugs. Drain plugs are located at the air receiver and compressor element. Catch the oil in a drain pan. Screw out the filler plug to speed up draining. Tighten the plugs after draining.
3. Remove the oil filter (3), e.g. by means of a special tool. Catch the oil in a drain pan.
4. Clean the filter seat on the manifold, taking care that no dirt drops into the system. Oil the gasket of the new filter element. Screw it into place until the gasket contacts its seat, then tighten one half turn only.
5. Fill the air receiver until the pointer of the oil level gauge (4) registers in the upper extremity of the green range. Take care that no dirt drops into the system. Reinstall and tighten the filler plug.
6. Run the unit at no load for a few minutes to circulate the oil and to evacuate the air trapped in the oil system.
7. Stop the compressor. Let the oil settle for a few minutes. Check that the pressure is released by opening an air outlet valve (5). Screw out filler plug (2) and add oil until the pointer of the oil level gauge (4) again registers in the upper extremity of the green range. Reinstall and tighten the filler plug.



Never add more oil. Overfilling results in oil consumption.

4.6 CLEANING COOLERS

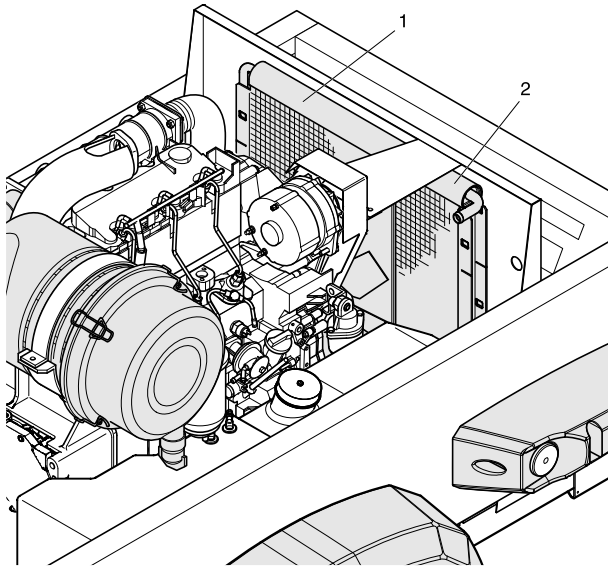

Fig. 4.3 Compressor oil cooler (1) and engine oil cooler (2)

Keep the oil-coolers (1) and (2) clean to maintain the cooling efficiency.

The fan side surface of compressor- and engine oil cooler is accessible by removing the fan cowl upper part.

The opposite surface of compressor- and engine oil cooler is accessible by removing the centre part of the front baffles.



Remove any dirt from the coolers with a fibre brush. Never use a wire brush or metal objects.

Steam cleaning in combination with a cleansing agent may be applied in order to remove also the dirt sticking to the cooler fins.



To avoid damaging the coolers, angle between jet and coolers should be approx. 90°.



Protect the electrical and controlling equipment, air filters, etc. against penetration of moisture.

Close the service door(s).



Never leave spilled liquids such as fuel, oil, water and cleansing agents in or around the compressor.

4.7 CLEANING FUEL TANK



Observe all relevant environmental and safety precautions.

Place an appropriate drain pan under the drainplug (Fig. 2.2, DP_{EC}) of the fuel tank.

Remove the drain plug.

Lift the towbar (Fig. 2.2, TB) and tilt the compressor approx. 15° to remove all fuel, dirt and water.

Clean the fuel tank and fix the drain plug handtight.



Never leave spilled liquids such as fuel, oil, water and cleansing agents in or around the compressor.

Refill the fuel tank with clean fuel.

4.8 CLEANING HARDHAT (OPTION)

Optimal cleaning of the hardhat can be obtained by applying high pressure cleaning or steam cleaning in combination with liquid soap.

4.9 BATTERY CARE



Before handling batteries, read the relevant safety precautions and act accordingly.

If the battery is still dry, it must be activated as described in section 4.9.2.

The battery must be in operation within 2 months from being activated; if not, it needs to be recharged first.

4.9.1 ELECTROLYTE



Read the safety instructions carefully.

Electrolyte in batteries is a sulphuric acid solution in distilled water.

The solution must be made up before being introduced into the battery.

4.9.2 ACTIVATING A DRY-CHARGED BATTERY

- Take out the battery.
- Battery and electrolyte must be at equal temperature above 10°C.
- Remove cover and/or plug from each cell.
- Fill each cell with electrolyte until the level reaches 10 to 15 mm above the plates, or to the level marked on the battery.
- Rock the battery a few times so that possible air bubbles can escape; wait 10 minutes and check the level in each cell once more; if required, add electrolyte.
- Refit plugs and/or cover.
- Place the battery in the compressor.

4.9.3 RECHARGING A BATTERY

Before and after charging a battery, always check the electrolyte level in each cell; if required, top up with distilled water only. When charging batteries, each cell must be open, i.e. plugs and/or cover removed.

 Use a commercial automatic battery charger according to its manufacturer's instructions.

Apply with preference the slow charging method and adjust the charge current according to the following rule of thumb:

battery capacity in Ah divided by 20 gives safe charging current in Amp.

4.9.4 BATTERY MAINTENANCE

- Keep the battery clean and dry.
- Keep the electrolyte level at 10 to 15 mm above the plates or at the indicated level; top up with distilled water only.
- Keep the terminals and clamps tight, clean, and lightly covered with petroleum jelly.

4.10 CHANGING TYRES

When changing a tyre, please observe that the arrow on the tyre in top position points in the driving direction (to the towbar).

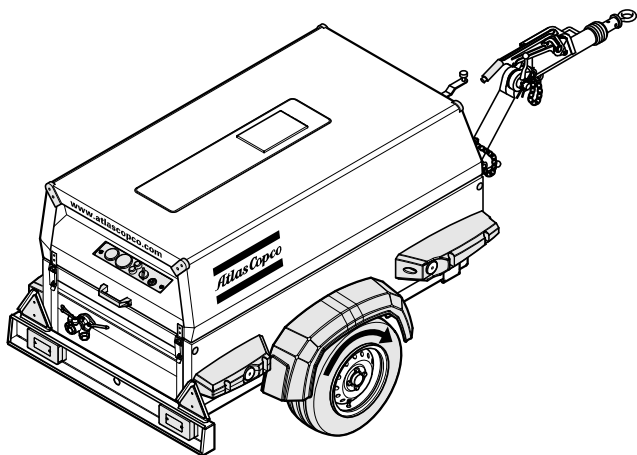

Fig. 4.4 Position of arrow on tyre

4.11 STORAGE

Run the compressor regularly, e.g. twice a week, until warm.

Load and unload the compressor a few times to operate the unloading and regulating components. Close the air outlet valves after stopping.



If the compressor is going to be stored without running from time to time, protective measures must be taken.

4.12 SERVICE PAKS

A Service Pak is a collection of parts to be used for a specific maintenance measure.

It guarantees that all necessary parts are replaced at the same time keeping down time to a minimum.

The order number of the Service Paks are listed in the Atlas Copco Parts List (ASL).

4.13 SERVICE KITS

A Service Kit is a collection of parts to fit a specific repair or rebuilding task.

It guarantees that all necessary parts are replaced at the same time which improves the uptime of the unit.

The order numbers of the Service Kits are listed in the Atlas Copco Parts List (ASL).



Contact Atlas Copco.

4.14 COMPRESSOR ELEMENT OVERHAUL

When a compressor element is due for overhaul, it is recommended to have it done by Atlas Copco. This guarantees the use of genuine parts and correct tools with care and precision.

4.15 LIABILITY

The manufacturer does not accept any liability for any damage arising from the use of non-original parts and for modifications, additions or conversions made without the manufacturer's approval in writing.

5. ADJUSTMENTS AND SERVICING PROCEDURES

5.1 ADJUSTMENT OF THE CONTINUOUS REGULATING SYSTEM

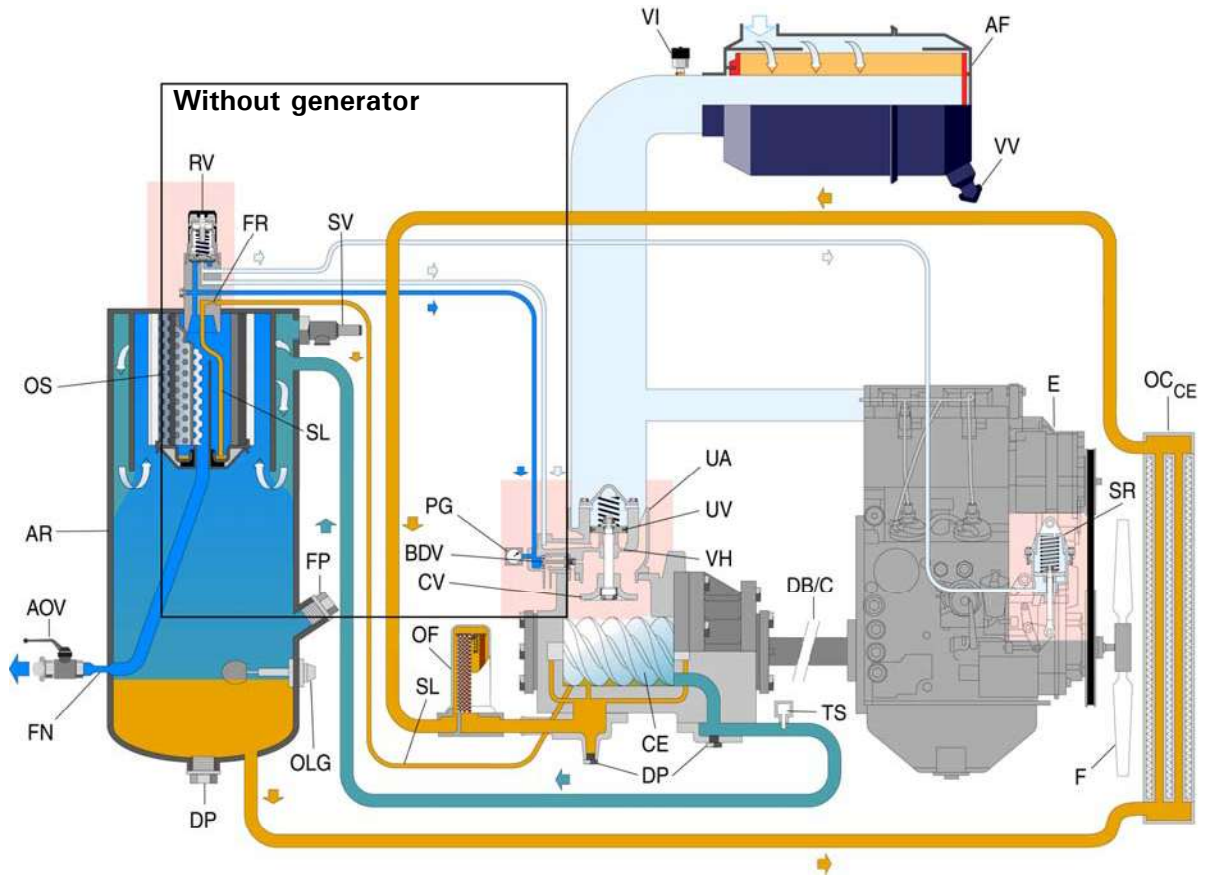
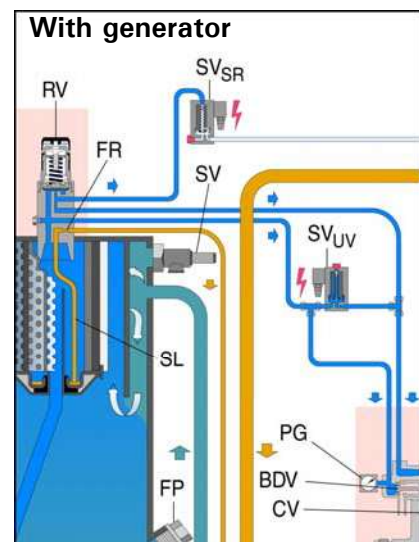

Fig. 5.1

The working pressure is determined by the tension of the spring in the regulating valve (RV). This tension can be increased to raise the pressure and decreased to lower it by turning the adjusting wheel clockwise and anti-clockwise respectively. To adjust the normal working pressure, proceed as follows:

1. Start and warm up the engine (see section 3.2).
2. With the outlet valves (AOV) closed, pull out the knob, adjust the regulating valve (RV) until a pressure of X bar(e) is reached (see table).
3. Check the minimum speed of the engine. Adjust minimum speed stop screw if necessary.
4. Open an outlet valve (AOV) just enough to let the engine (E) run at maximum speed. The working pressure must be Y bar(e) (see table); adjust if necessary with regulating valve (RV).
5. Check the engine maximum speed. Adjust the maximum speed by means of adjusting eccentric nut on top of speed regulator (SR).
6. Close the outlet valves (AOV), check that the pressure is between Z1 and Z2 bar(e) (see table). Lock the regulating valve (RV) by pushing the knob down.
7. Check the operation of the solenoid valve (SV_{SR}) when equipped with a generator.



Table

	X bar(e)	Y bar(e)	Z1 – Z2 bar(e) bar(e)
XAS 67 Dd	8.5	7	8.3 – 8.7
XATS 67 Dd	11.8	10.3	11.6 – 12
XAS 77 Dd	8.5	7	8.3 – 8.7
XAS 97 Dd	8.5	7	8.3 – 8.7

5.2 AIR FILTER ENGINE/COMPRESSOR

5.2.1 MAIN PARTS

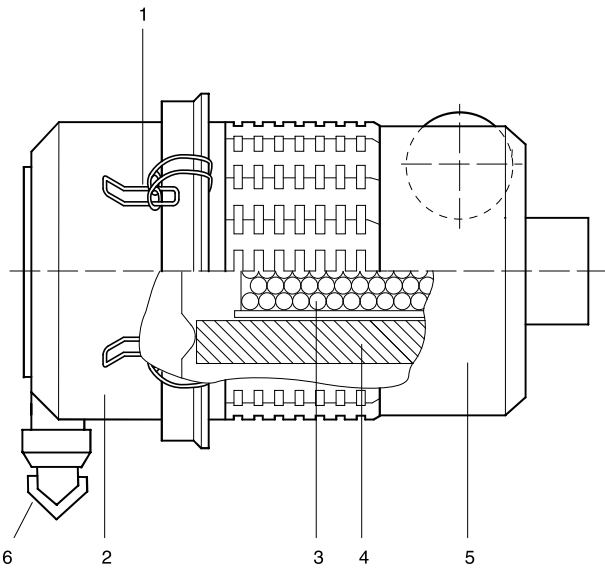

Fig. 5.2 Air filter

- 1 Snap clips
- 2 Dust trap
- 3 Safety cartridge (option)
- 4 Filter element
- 5 Filter housing
- 6 Vacuator valve

5.2.2 RECOMMENDATIONS



The Atlas Copco air filters are specially designed for the application. The use of non-genuine air filters may lead to severe damage of engine and/or compressor element.

Never run the compressor without air filter element.

New elements must also be inspected for tears or punctures before installation.

Discard the element (4) when damaged.

In heavy duty applications it is recommended to install a safety cartridge which can be ordered with XAS 67 Dd, XATS 67 Dd, XAS 77 Dd - part no.: 2914 9309 00 XAS 97 Dd - part no.: 2914 9311 00

A dirty safety cartridge (3) is an indication of a malfunctioning air filter element. Replace the element and the safety cartridge in this case.

The safety cartridge cannot be cleaned.

5.2.3 CLEANING THE DUST TRAP

To remove dust from the dust trap pinch the vacuator valve (6) several times.

5.2.4 REPLACING THE AIR FILTER ELEMENT

1. Release the snap clips (1) and remove the dust trap (2). Clean the trap.
2. Remove the element (4) from the housing (5).
3. Reassemble in reverse order of dismantling.
4. Inspect and tighten all air intake connections.
5. Reset the vacuum indicator (Fig. 5.3).

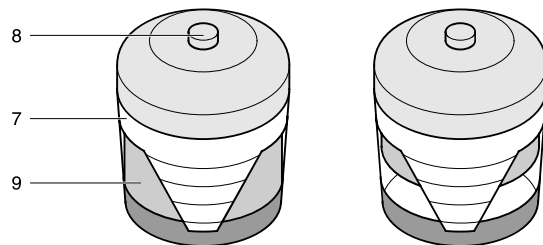

Fig. 5.3 Vacuum indicator

- 7 Air filter contamination indicator
- 8 Reset button
- 9 Yellow indicator

5.3 AIR RECEIVER

The air receiver is tested according to official standards. Regularly have inspections carried out in conformity with local regulations.

5.4 SAFETY VALVE



All adjustments or repairs are to be done by an authorized representative of the valve supplier.

Following checks must be carried out:

- a check of the opening of the lifting gear, twice a year. This can be done by screwing the cap of the valve anti-clockwise.
- a check of the set pressure once a year according to the local regulations. This check cannot be done on the machine and must be carried out on a proper test bench.

5.5 FUEL SYSTEM

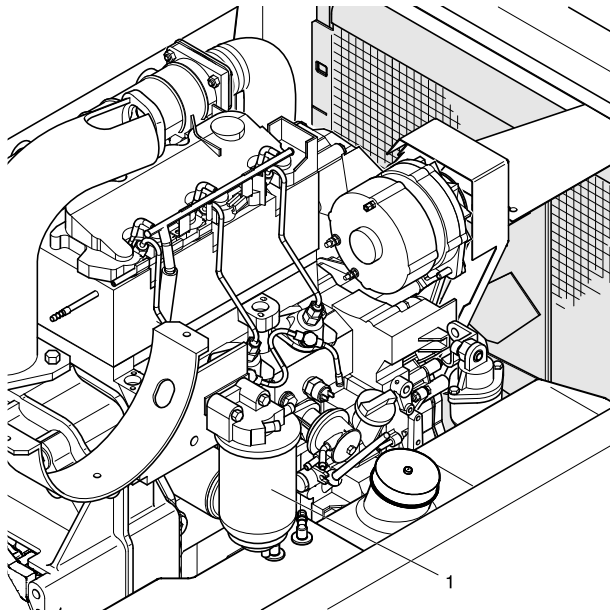

Fig. 5.4 Fuel filter

Replacing the filter element

1. Unscrew the filter element (1) from the adapter head.
2. Clean the adapter head sealing surface. Lightly oil the gasket of the new element and screw the latter onto the header until the gasket is properly seated, then tighten with both hands.
3. Check for fuel leaks once the engine has been restarted.

5.6 BRAKE (= OPTION) ADJUSTMENT



Before jacking up the compressor, connect it to a towing vehicle or attach a weight of minimum 50 kg to the towbar.

5.6.1 BRAKE SHOE ADJUSTMENT

Check the thickness of the brake lining. Remove both black plastic plugs (5), one on each wheel. When the brake lining has been worn to a thickness of 2 mm or less, the brake shoes have to be replaced. After inspection and/or replacement re-insert both plugs.

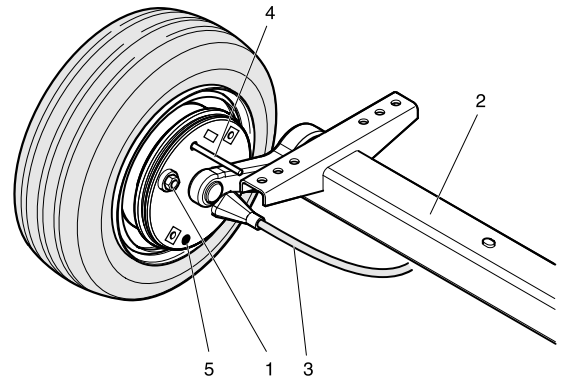

Fig. 5.5 Brake shoe adjustment

- 1 Adjusting bolt
- 2 Axle
- 3 Brake cable
- 4 Pin \varnothing 4 mm
- 5 Plug

Brake shoe adjustment re-establishes the brake lining-to-drum clearance and compensates for lining wear.

Lift and support the compressor. Make sure that all brakes are off (overrunbrake and hand brake lever). The brake cables must be free from tension. Lock the swivel cams of the wheel brake from the outside by means of a pin \varnothing 4 mm (4) through the hole as shown in Fig. 5.5.

Turn the adjusting bolt (1) clockwise with a wrench till the wheel locks up. Center the brake shoes by actuating the parking brake several times.

Turn the adjusting bolt anti-clockwise until the wheel is running free in direction of travel (approx. 1 full turn of the adjusting bolt).

Check the position of the equalizer (Fig. 5.7, 6) with the parking brake actuated.

Perpendicular position of equalizer = identical clearance of wheel brakes.

Re-adjust the brake shoes, if necessary.

To test, slightly apply the parking brake and check identical brake torque on left and right side.

Remove locking pin (4). Remove clearance from brake cables.

Check all lock nuts (Fig. 5.7, 2).

5.6.2 TEST PROCEDURE OF BRAKE CABLE ADJUSTMENT

1. Check if the towing eye rod of the overrun brake mechanism is in the outmost position.
2. Check if the adjustable towbar (= option) is in the actual towing position.
3. Apply the hand brake lever.
4. Push the compressor a few centimeters backwards so that the brake lever is automatically pulled further up.
5. Check the position of the arrow marking "1" at the catch lock in combination with the arrow marking "2" at the toothed sector, according to Fig. 5.6 A,B,C,D.

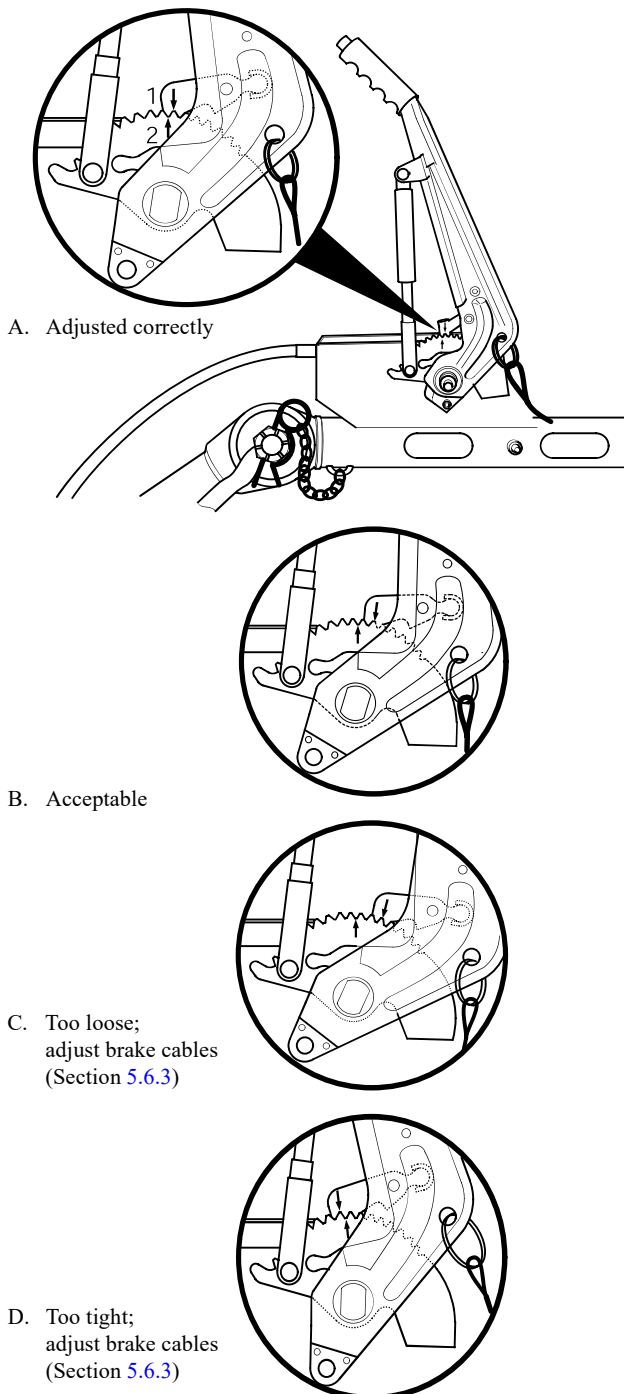

Fig. 5.6 Correct and wrong position of markings

5.6.3 BRAKE CABLE ADJUSTMENT

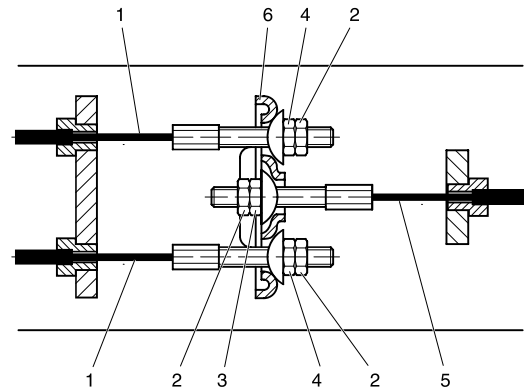

Fig. 5.7 Brake cable arrangement

- 1 Brake cable
- 2 Lock nut
- 3 Adjusting nut
- 4 Brake cable nut
- 5 Main brake cable
- 6 Equalizer

1. With the towing eye pulled out in the outmost position and the hand brake lever in the downward position (Fig. 5.8), loosen the lock nuts (Fig. 5.7, 2). Turn adjusting nuts and brake cable nuts (Fig. 5.7, 4) clockwise until there is no slack in the brake mechanism.

The equalizer (Fig. 5.7, 6) must remain perpendicular to main brake cable (Fig. 5.7, 5).

2. Apply the hand brake lever several times and repeat the adjustment. Tighten the nuts with their lock nuts (Fig. 5.7, 2). Remove the jack and the blocks.
3. Road test the compressor and brake several times. Check brake shoe and brake cable adjustment and if necessary adjust.

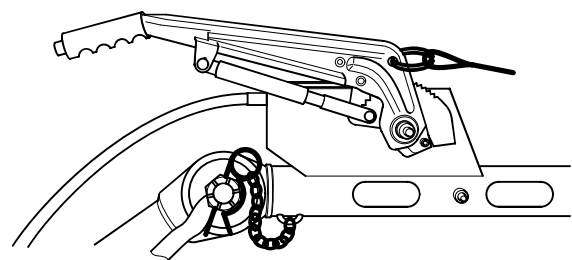

Fig. 5.8 Hand brake lever downward - brake not operated

5.7 DRIVE BELT (XAS 67 DD, XATS 67 DD)



Never retense or reuse the drive belt between engine and compressor.

Consult Atlas Copco for replacement of drive belt.

6. PROBLEM SOLVING

It is assumed that the engine is in good condition and that there is adequate fuel flow to the filter and injection equipment.



An electrical fault must be traced by an electrician.

Make sure that the wires are not damaged and that they are clamped tight to their terminals.



If it's not possible to solve the problem with this problem solving table, please consult Atlas Copco.

6.1 ALTERNATOR PRECAUTIONS

1. Never reverse the polarity of the battery or the alternator.
2. Never break any alternator or battery connections while the engine is running.
3. When recharging the battery, disconnect it from the alternator. Before using booster cables to start the engine, be sure of the polarity and connect the batteries correctly.
4. Never operate the engine without the main or voltage sensing cables connected in the circuit.

Problem	Possible faults	Corrective actions
1. Lamps (H1, H2) do not light up when switching (S1) to "I" and applying lamp test.	<ol style="list-style-type: none"> a. Discharged or defective battery. b. Loose battery cable(s) or oxidised terminals. c. Loose connection or damaged wiring. d. Contact switch (S1) defective. e. Circuit breaker (F1) defective. 	<ol style="list-style-type: none"> a. Check electrolyte level and charge battery. If no cells are shorted and battery is discharged, trace cause and correct. b. Check and correct if necessary. c. Check wiring and connections; correct if necessary. d. With (S1) switched in "I", check voltage between earth and respectively each of the terminals of (S1). Voltage must register at each of the terminals; if not, replace (S1). e. Replace circuit breaker.
2. General alarm lamp (H2) does not light up when switching (S1) to „I“; lamp (H1) lights up when applying lamp test.	<ol style="list-style-type: none"> a. Lamp (H2) blown. b. Alternator (A)/regulator defective. 	<ol style="list-style-type: none"> a. Replace lamp. b. Disconnect the wire from alternator terminal D+ and connect it to terminal D-. If (H1) lights up, replace the alternator; if not, test (S1); see remedy 1d.
3. Temperature alarm lamp (H1) does not light up when switching (S1) to „I“ and applying lamp test.	<ol style="list-style-type: none"> a. Lamp (H1) blown b. See fault 1d. 	<ol style="list-style-type: none"> a. Replace lamp. b. See 1d.
4. Starter motor (S) does not crank engine (E) after switching startbutton (S1) to "I".	<ol style="list-style-type: none"> a. Low battery output. 	<ol style="list-style-type: none"> a. See remedy 1a.
5. Starter motor cranks engine when switching start switch (S1) to "I", but engine does not fire.	<ol style="list-style-type: none"> a. Contact switch (S1) defective. b. Fuel solenoid (Y1) defective. c. Low battery output. 	<ol style="list-style-type: none"> a. See remedy 1d. b. Check solenoid and its valve, correct or replace if necessary. c. See 1a.
6. Engine fires, but general alarm lamp (H2) remains alight; engine stops when releasing start switch (S1).	<ol style="list-style-type: none"> a. Alternator drive belt broken or slipping. b. Alternator (A)/regulator defective. 	<ol style="list-style-type: none"> a. Check and correct if necessary. b. Have assembly repaired.
7. Engine is running, but shuts down immediately after (S1) has been released.	<ol style="list-style-type: none"> a. Contact switch (S1) released too soon. b. Insufficient engine oil pressure. c. Fuel tank contains insufficient fuel. 	<ol style="list-style-type: none"> a. Release switch after engine oil pressure has built up above the minimum allowed value. b. Stop at once, consult the Engine Operation Manual. c. Fill fuel tank.
8. General alarm lamp (H2) remains alight for over 5 seconds after starting.	<ol style="list-style-type: none"> a. Insufficient engine oil pressure or too high engine oil temperature. b. Engine oil pressure switch (S3), or compressor temperature switch (S5) defective. c. Relay (K1) defective. 	<ol style="list-style-type: none"> a. Stop at once, consult Engine Operation Manual. b. Stop at once, test switches, replace as necessary. c. Replace (K1).

Problem	Possible faults	Corrective actions
9. Hourmeter (P1) does not count running time.	a. Hourmeter (P1) defective.	a. Replace.
10. Compressor does not unload and engine keeps running at maximum speed when closing the air outlet valves; safety valve blows.	a. Air leaks in regulating system. b. Regulating valve (RV) incorrectly set or defective. c. Unloading valve (UV) or its actuating piston stuck.	a. Check and repair. b. Adjust or repair regulating valve; see section 5.1. c. Repair unloading valve assembly.
11. Compressor capacity or pressure below normal.	a. Air consumption exceeds capacity of compressor. b. Choked air filter elements (AF). c. Unloading valve (UV) not completely open. d. Engine does not run at max. speed. e. Oil separator element (OS) clogged.	a. Check equipment connected. b. Replace air filter element (AF). c. Speed regulation cable maladjusted; see section 5.1. d. Check the maximum speed, service the fuel filter. e. Have element removed and inspected by an Atlas Copco Service representative.
12. Working pressure rises during operation and causes safety valve to blow.	a. See faults 10. b. Safety valve (SV) opens too soon.	a. See remedies 10. b. Have safety valve adjusted; consult Atlas Copco.
13. Excessive compressor oil consumption. Oil mist being discharged from air outlet valve(s).	a. Restrictor in oil scavenging line (SL) clogged. b. Oil separator element (OS) defective. c. Oil level too high.	a. Dismount, clean and refit restrictor. b. Replace element. c. Check for overfilling. Release pressure and drain oil to correct level.
14. Compressor shuts down through a shutdown switch.	a. Alternator V-belt broken or slipping. b. Compressor overheating. c. Engine oil pressure too low. d. Engine temperature too high.	a. Re-tense or replace V-belt. b. See condition 16. c. Check lubricating system. d. Check engine oil system; see Engine Operation Manual.
15. Air and oil mist expelled from air filter after stopping.	a. Unloader valve (UV) defective. b. Wrong oil type (without foam-retarding additives).	a. Repair valve. b. Consult Atlas Copco.
16. Compressor overheating.	a. Insufficient compressor cooling. b. Oil cooler (OC) clogged externally. c. Oil system clogged internally. d. Oil level too low.	a. Relocate compressor. b. Clean cooler; see section 4.6. c. Consult Atlas Copco. d. See section 4.4.
XAS 67 Dd, XATS 67 Dd:		
17. No air output.	a. Drive belt broken.	a. See section 5.7.
Generator DdG 110V:		
18. Circuit breakers are off (down).	a. Short circuit or overload. b. Circuit breakers switched off.	a. Remedy fault. Switch on circuit breakers. b. Switch on circuit breakers.
19. Green lamp H3 is deactivated.	a. Circuit breakers are off. b. Serious electrical fault.	a. Switch on circuit breakers. b. Consult Atlas Copco.
Generator DdG IT 230/400V:		
20. Circuit breakers Q1 are off (down).	a. Short circuit. b. Temperature in generator too high.	a. Remedy fault. Switch on circuit breakers. b. Check generator cooling.
21. Green lamp H3 is deactivated.	a. Circuit breakers are off. b. Serious electrical fault.	a. Switch on circuit breakers. b. Consult Atlas Copco.

7. AVAILABLE OPTIONS

Canopy	Poly Ethylene
Pressure vessel approval:	CE ASME
Undercarriage:	Adjustable towbar with brakes Fixed towbar with brakes Fixed towbar without brakes Support (without undercarriage) ¹⁾ Simplified bumper ¹⁾
Towing eyes:	Atlas Copco DIN Ball coupling ITA GB 50 mm NATO Loose ball coupling
Towbar support:	Support leg Jockey wheel
Road lights system:	Reflectors only Road lights system 24 V adaptor
Air quality equipment:	Aftercooler + water separator Aftercooler + water separator + PD filter Aftercooler + water separator + PD/QD filters Aftercooler + water separator + reheater ²⁾ Aftercooler + water separator + PD filter + reheater ¹⁾ Aftercooler + water separator + PD/QD filters + reheater ¹⁾ Lubricator ²⁾ Anti-frost device ²⁾ By-pass ²⁾
Tool box:	Single Twin
Safety:	Wheel chocks Safety cartridge Spark arrester ¹⁾ Safety chain CE/ASME Anti-theft ³⁾ Hose reel ¹⁾ Inlet shutdown valve ¹⁾ Spillage free frame Particle filter ¹⁾ Non return valve Additional literature set Metal fillerneck fueltank
Cold start:	Cold start – 20 °C
Generator ⁴⁾ :	230/400 V - 6.5 kVA 230/400 V - 6.5 kVA Automatic 230 V - 3 ph - 6.5 kVA 110 V - 6 kVA 110 V - 6 kVA Automatic 230 V - 3 ph - 12.5 kVA 230/400 V - 12.5 kVA 230/400 V - 12.5 kVA Automatic
Canopy colour:	single double ¹⁾

¹⁾ Not in combination with hardhat

²⁾ Not on XATS 67 Dd.

³⁾ In order to obtain a spare key at the local ABUS dealer, the key code card must be presented. Please keep this card available.

⁴⁾ Only for XAS 67 Dd and XAS 97 Dd with standard canopy.

8. TECHNICAL SPECIFICATIONS

8.1 TORQUE VALUES

8.1.1 FOR GENERAL APPLICATIONS

The following tables list the recommended torques applied for general applications at assembly of the compressor.

For hexagon screws and nuts with strength grade 8.8

Thread size	M6	M8	M10	M12	M14	M16
Nm	9	23	46	80	125	205

For hexagon screws and nuts with strength grade 12.9

Thread size	M6	M8	M10	M12	M14	M16
Nm	15	39	78	135	210	345

8.1.2 FOR IMPORTANT ASSEMBLIES

Assemblies	Unit	Torque values	
Wheel nuts	Nm	80	+10/-0
Bolts, axle/beams	Nm	80	+/- 10
Bolts, towbar/axle	Nm	80	+/- 10
Bolts, towbar/bottom	Nm	80	+/- 10
Bolts, towing eye/towbar	Nm	80	+/- 10
Bolts, lifting eye/flywheel housing	Nm	205	+ 20
Bolts, engine/drive housing (M12)	Nm	80	+/- 10
Bolts, engine/drive housing (M14)	Nm	125	+/- 10
Bolts, compressor element/drive housing	Nm	80	+/- 5
Safety switches	Nm	35	+/- 5
Joints adjustable towbar (M24)	Nm	275	+/- 25
(M32)	Nm	375	+/- 25

Note:

Secure the tank cap and drain plug of the fuel tank handtight.

8.2 SETTINGS OF SHUTDOWN SWITCHES AND SAFETY VALVES

Compressor type		XAS 67 Dd	XATS 67 Dd	XAS 77 Dd	XAS 97 Dd
Designation	Unit	Value	Value	Value	Value
Engine oil pressure	bar(e)	1.2	1.2	1.2	1.2
Engine oil temperature	°C	127 - 133	127 - 133	127 - 133	127 - 133
Compressor temperature	°C	116 - 120	116 - 120	116 - 120	116 - 120
Safety valve opening pressure					
EC type	bar(e)	10.5	14.5	10.5	10.5
ASME type	psi	160	210	160	160

8.3 COMPRESSOR/ENGINE SPECIFICATIONS

Compressor type		XAS 67 Dd	XAS 67 DdG / DdG IT	XATS 67 Dd	XAS 77 Dd	XAS 97 Dd
Designation	Unit	Value	Value	Value	Value	Value
Reference conditions						
1. Absolute inlet pressure	bar(e)	1	1	1	1	1
2. Relative air humidity	%	0	0	0	0	0
3. Air inlet temperature	°C	20	20	20	20	20
4. Nominal effective working pressure	bar(e)	7	7	10.3	7	7
The inlet conditions are specified at the air inlet grating outside the canopy						
Limitations						
1. Minimum effective receiver pressure	bar(e)	2.9	3	4	3.3	4
2. Maximum effective receiver pressure, compressor unloaded	bar(e)	8.5	8.5	11.8	8.5	8.5
3. Maximum ambient temperature at sealevel ⁶⁾	°C	45	45	45	45	45
4. Minimum starting temperature	°C	- 10	- 10	- 10	- 10	- 10
5. Minimum starting temperature, with coldstart equipment ⁵⁾	°C	- 20	- 20	- 20	- 20	- 20
6. Altitude capability	m	See separate curves below				

Machine Verhuur Oosterwolde

Altitude unit performance curves
 Max. allowable working pressure as a function altitude and ambient temperature.

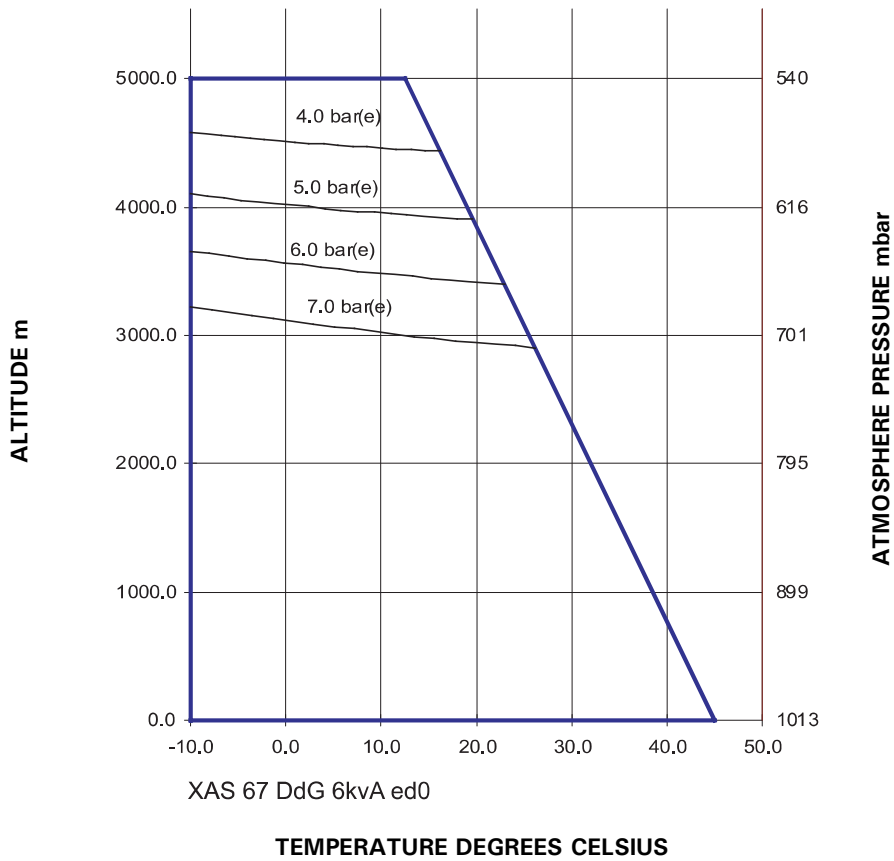
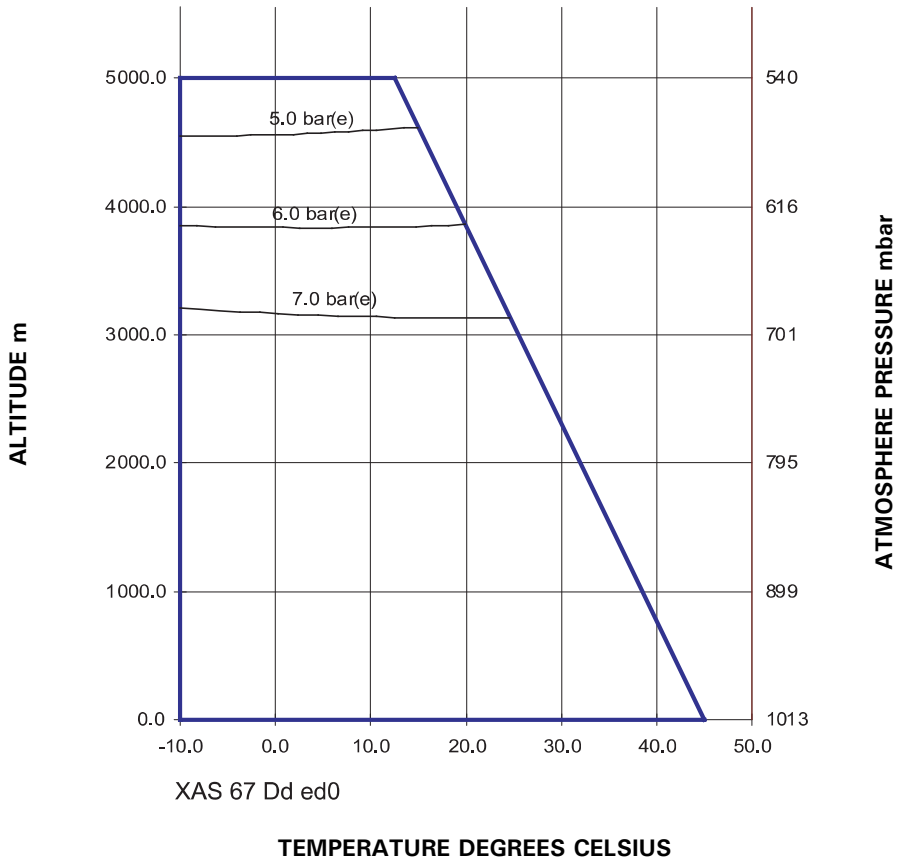

Altitude unit performance curves

Max. allowable working pressure as a function altitude and ambient temperature.

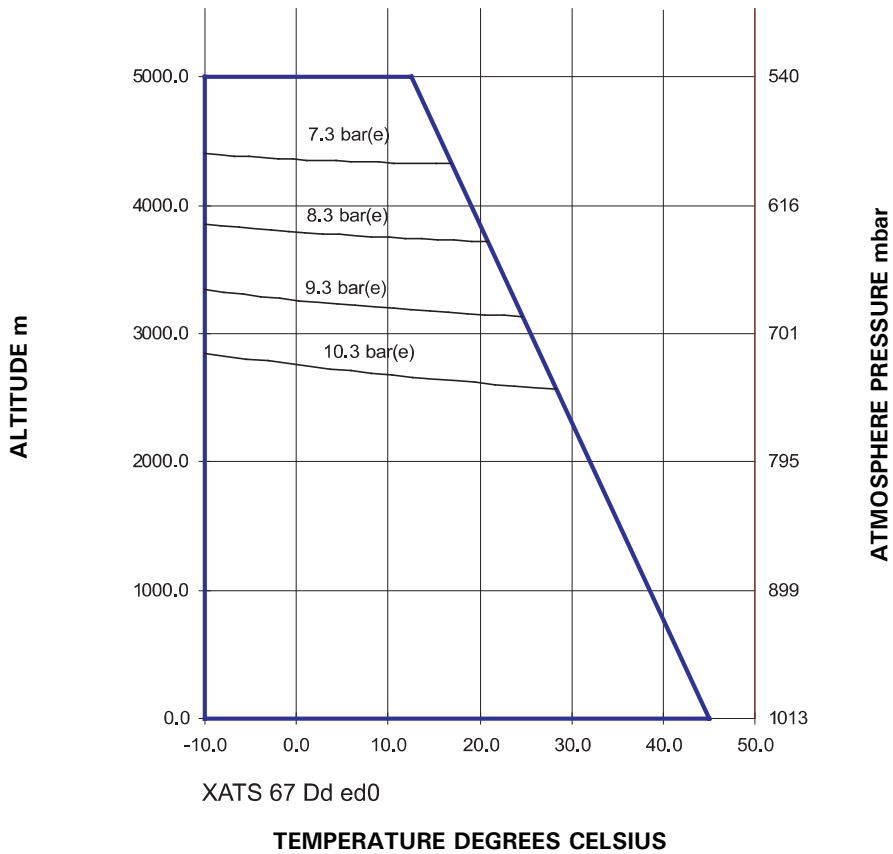
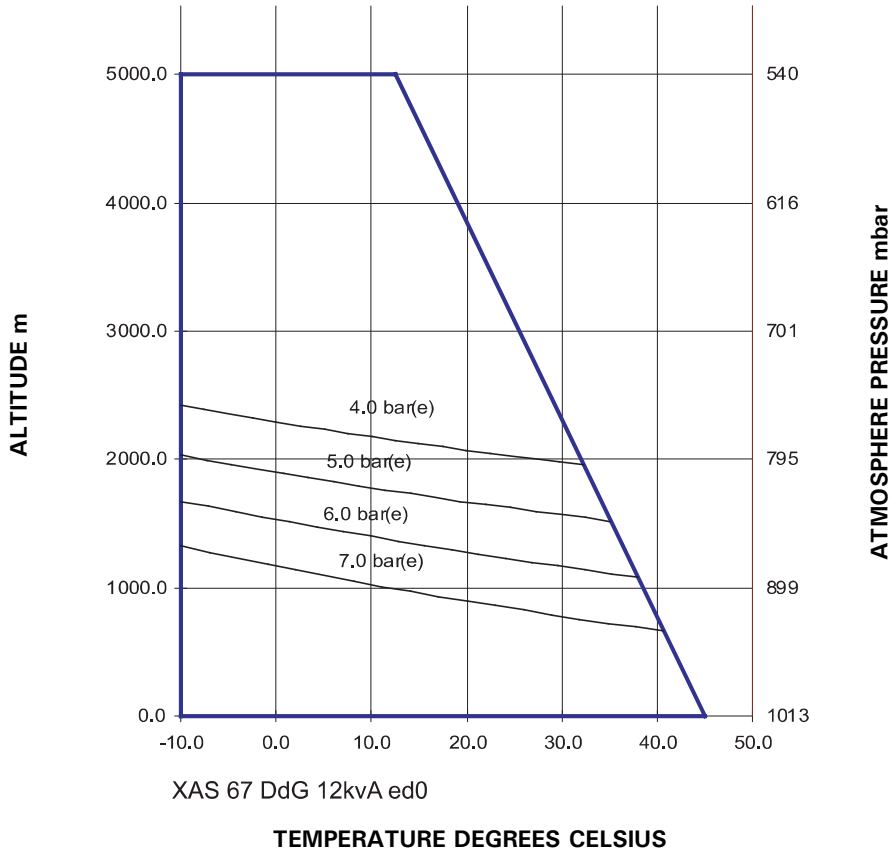

Altitude unit performance curves

Max. allowable working pressure as a function altitude and ambient temperature.

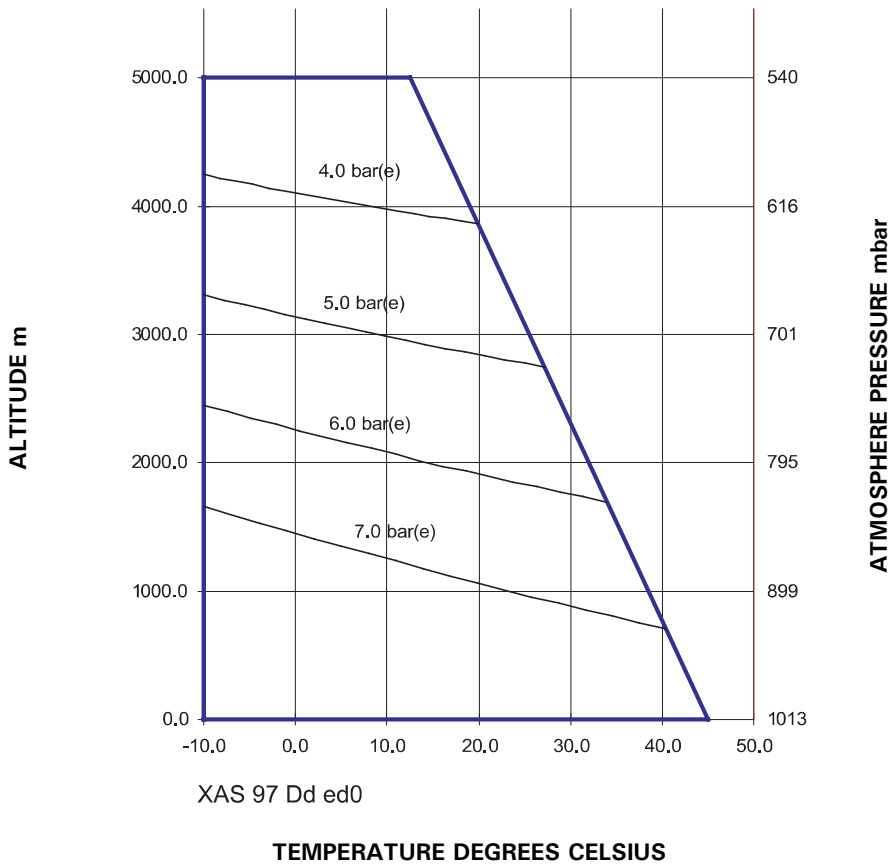
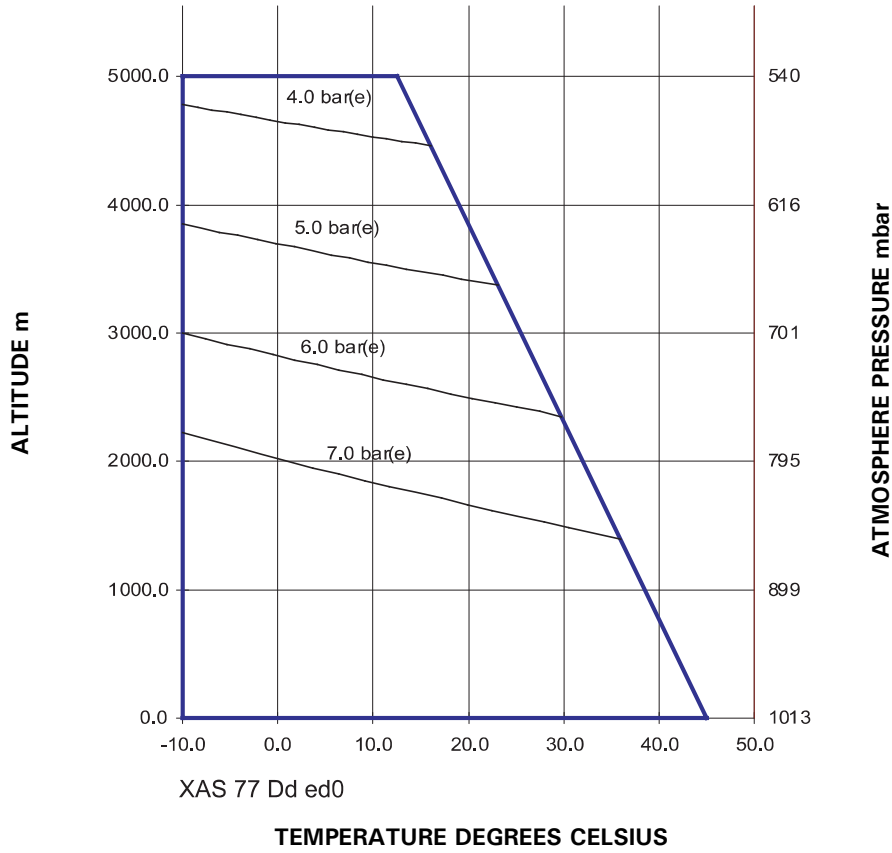

Compressor type		XAS 67 Dd	XAS 67 DdG/ DdG IT	XATS 67 Dd	XAS 77 Dd	XAS 97 Dd	XAS 97 DdG/ DdG IT
Designation	Unit	Value	Value	Value	Value	Value	Value
Performance data ¹⁾							
1. Engine shaft speed, normal and maximum	r/min	2,400	2,750	2,750	2,300	2,750	2,750
2. Engine shaft speed, compressor unloaded	r/min	1,850	1,850	1,850	1,850	1,850	1,850
3. Engine shaft speed, generator at maximum load	r/min	-	2,700	-	-	-	2,700
4. Free air delivery ²⁾	l/s	62	58	57	72	88	89
5. Fuel consumption:							
- at full load	kg/h	6	-	7	6	7.2	-
- at full load + generator	kg/h	-	7.2	-	-	-	7.2
- at unload	kg/h	2.7	3.9	3.4	2.7	3.6	3.6
6. Specific fuel consumption	g/m ³	27.4	35.7	34.5	27.4	23.3	23.3
7. Typical oil content of compressed air	mg/m ³ free air	< 5	< 5	< 5	< 5	< 5	< 5
8. Engine oil consumption (maximum)	g/h	17	20	37	17	37	37
9. Compressed air temperature at outlet valves	°C	89	94	90	89	90	90
10. Noise level							
- Sound pressure level (LP), measured according to ISO 2151 under free field conditions at 7 m distance	dB(A)	70	70	70	70	72	72
- Sound power level (LW) complies with 2000/14/EC	dB(A)	98	98	100	98	100	100

Compressor type		XAS 67 Dd	XAS 67 DdG/ DdG IT	XATS 67 Dd	XAS 77 Dd	XAS 97 Dd	XAS 97 DdG/ DdG IT
Designation	Unit	Value	Value	Value	Value	Value	Value
Design data							
Compressor							
1. Number of compression stages		1	1	1	1	1	1
Engine							
1. Make		KHD	KHD	KHD	KHD	KHD	KHD
2. Type		F3M2011	F3M2011	F3M2011	F3M2011	F3M2011	F3M2011
3. Coolant		Oil	Oil	Oil	Oil	Oil	Oil
4. Number of cylinders		3	3	3	3	3	3
5. Bore	mm	94	94	94	94	94	94
6. Stroke	mm	112	112	112	112	112	112
7. Swept volume	l	2.332	2.332	2.332	2.332	2.332	2.332
8. Output according to ISO 9249 G at normal shaft speed	kW	32.5	36	36	31.5	36	36
- Load factor	%	50	50	50	50	50	50
9. Capacity of oil sump:							
- Initial fill	l	8.5	8.5	8.5	8.5	8.5	8.5
- Refill (max.) ⁴⁾	l	6	6	6	6	6	6
10. Capacity of cooling system	l	-	-	-	-	-	-
Unit							
1. Capacity of compressor oil system	l	8	8	8	8	8	8
2. Net capacity of air receiver	l	16.7	16.7	16.7	16.7	16.7	16.7
3. Capacity of fuel tank	l	80	80	80	80	80	80
4. Air volume at inlet grating (approx.) ³⁾	m ³ /s	0.85	0.85	0.85	0.93	1.2	0.81

1) At reference conditions, if applicable, and at normal shaft speed, unless otherwise stated.

2) Data	Measured according to	Tolerance
Free air delivery	ISO 1217 ed.3 1996 annex D	+/- 5% 25 l/s <FAD < 250 l/s +/- 4% 250 l/s <FAD

The international standard ISO 1217 corresponds to following national standards:

- British BSI 1571 part 1
- German DIN 1945 Part 1
- Swedish SS-ISO 1217
- American ANSI PTC9

3) Air required for engine and compressor cooling, combustion and for compression.

4) with filter change

5) Coldstart: compressor oil DTE22 instead of DTE25

6) For Hose Reel application: maximum ambient temperature 30°C

Generator type			DdG 110V (XAS 67 DdG / DdG IT - XAS 97 DdG / DdG IT)	DdG IT 230V - 3 ph - 6 kVA (XAS 67 DdG / DdG IT - XAS 97 DdG / DdG IT)	DdG IT 230/400V - 3 ph - 6 kVA (XAS 67 DdG / DdG IT - XAS 97 DdG / DdG IT)	DdG IT 230V - 3 ph - 12.5 kVA (XAS 97 DdG / DdG IT)
Designation	Unit		Value	Value	Value	Value
Alternator						
1. Standard			IEC 34-1	IEC 34-1	IEC 34-1	IEC 34-1
2. Make			MECC ALTE	MECC ALTE	MECC ALTE	MECC ALTE
3. Model			MR-1 -180/2	TR-1 -160/2	TR-1 -160/2	TR-2 -200/2
4. Rated output	kVA		6	6	6	12.5
5. Degree of protection	IP		23	23	23	23
6. Insulation - stator	class		H	H	H	H
- rotor	class		H	H	H	H
7. Number of phases			1	3	3	3
8. Number of leads			4	6	6	6
Electrical power circuit						
1. Rated continuous active power	COP	kW	5.5	4.8	4.8	9.6
2. Rated power factor (lagging)			1	0.8	0.8	0.8
3. Rated continuous apparent power 1 ph	COP	kVA	5.5	4	4	
4. Rated voltage 1ph line to line		V	110	230	230	230
5. Rated current 1ph		A	50	16	16	16
6. Frequency droop		%	<5	<5	<5	<5
7. Rated continuous apparent power 3 ph	COP	kVA		6	6	12
8. Rated voltage 3ph line to line		V		230	400	230
9. Rated current 3ph		A		15	8.7	30.1
Circuit breaker						
1. Number of poles			2	3	4	3
2. Rated current	In	1ph A	50			
	In	1ph/3ph A		16/16	16/10	16/32
3. Thermal release	It	1ph A	50			
	It	1ph/3ph A		16/16	16/10	16/32
4. Magnetic release	Im	A	3..5 In	3..5 In	3..5 In	3..5 In
Fault current protection						
Insulation resistance		kOhm		10-80	10-80	10-80
Residual current release	Idn	A	0.03			

Compressor type		XAS 67 Dd		XATS 67 Dd		XAS 77 Dd		XAS 97 Dd	
Designation	Unit	Value	Value	Value	Value	Value	Value	Value	Value
Unit dimensions									
		towbar		towbar		towbar		towbar	
without brakes		fixed	adjustable	fixed	adjustable	fixed	adjustable	fixed	adjustable
Length	mm	3,016	N.A.	3,016	N.A.	3,016	N.A.	3,016	N.A.
Width	mm	1,410	1,410	1,410	1,410	1,410	1,410	1,410	1,410
Height	mm	1,258	1,258	1,258	1,258	1,258	1,258	1,258	1,258
Weight (ready to operate)	kg	880	N.A.	880	N.A.	890	N.A.	890	N.A.
		towbar		towbar		towbar		towbar	
with brakes		fixed	adjustable	fixed	adjustable	fixed	adjustable	fixed	adjustable
Length	mm	3,129	3,496-3,664	3,129	3,496-3,664	3,129	3,496-3,664	3,129	3,496-3,664
Width	mm	1,410	1,410	1,410	1,410	1,410	1,410	1,410	1,410
Height	mm	1,258	1,258	1,258	1,258	1,258	1,258	1,258	1,258
Weight (ready to operate)	kg	915	930	915	930	925	940	925	940

8.4 CONVERSION LIST OF SI UNITS INTO BRITISH UNITS

1 bar	=	14.504 psi
1 g	=	0.035 oz
1 kg	=	2.205 lb
1 km/h	=	0.621 mile/h
1 kW	=	1.341 hp (UK and US)
1 l	=	0.264 US gal
1 l	=	0.220 Imp gal (UK)
1 l	=	0.035 cu.ft
1 m	=	3.281 ft
1 mm	=	0.039 in
1 m ³ /min	=	35.315 cfm
1 mbar	=	0.401 in wc
1 N	=	0.225 lbf
1 Nm	=	0.738 lbf.ft
t °F	=	32 + (1.8 x t °C)
t °C	=	(t °F - 32)/1.8

– A temperature difference of 1 °C = a temperature difference of 1.8 °F

9. DATA PLATE



1. Company code
2. Product code
3. Unit serial number
4. Name of manufacturer
5. EEC or national type approval number
6. Vehicle identification number
7. A Maximum permitted laden weight of the vehicle
B Maximum permitted road weight of the vehicle
C Maximum permitted laden weight of the towing eye
8. Model
9. Working pressure
10. Speed
11. Engine power
12. Manufacturing year
13. CE-mark in accordance with Machine Directive 89/392/EEC
14. Register number or number of notified body

Machine Verhuur Oosterwolde

Notes

Machine Verhuur Oosterwolde

Machine Verhuur Oosterwolde

Machine Verhuur Oosterwolde



www.atlascopco.com

Printed in Belgium 12/2005 - 2954 2150 02